

## LED Displacement Sensor

## Z4W-V

Low-cost LED Displacement Sensor  
Offers 10-micron Resolution

- Measurement point of 25 mm (0.98 in) with measurement range of  $\pm 4$  mm (0.16 in).
- Easy-to-use, built-in amplifier.
- Fast 5-millisecond response.
- Visible beam spot means easy installation.
- Range and stability indicators simplify set-up and monitoring.
- IP66 enclosure rating.
- LED light source does not require the safety precautions of a laser-type light source.
- For signal processing or PLC communication, use with K3TX or K3TS intelligent Panel Meter.



## Ordering Information

Sensing distance	Resolution	Part number
25 $\pm$ 4 mm	10 $\mu$ m	Z4W-V25R

## Application Examples

### Checking a Dimension After Assembly

Z4W-V25R LED Displacement Sensor

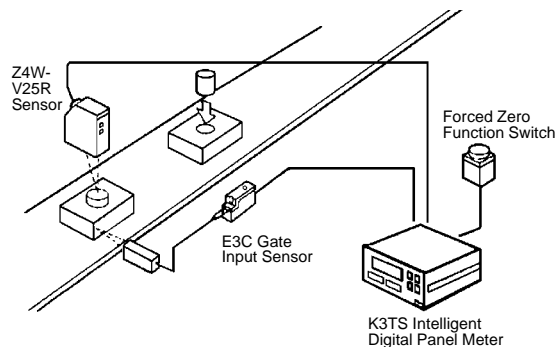

### Measuring Height Difference

Two Z4W-V25R LED Displacement Sensors

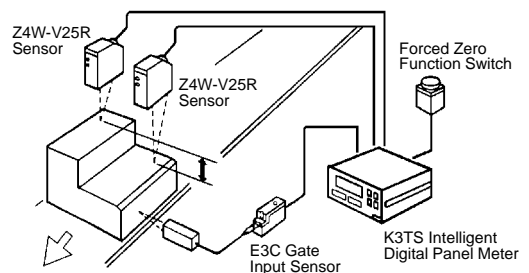

# Specifications

## ■ RATINGS

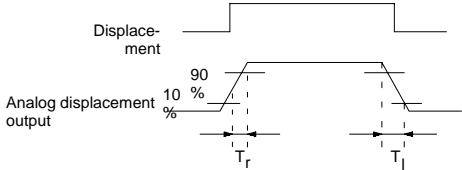
Measurement range	±4 mm (0.16 in)	
Measurement point	25 ±1 mm (0.98 in)	
Light source	Red LED	
Spot diameter	2-mm (0.079 in) dia. at measurement point	
External light	3,000 lux (incandescent light)	
Resolution	10 microns The resolution is the peak-to-peak displacement conversion value of the analog output. (Conditions: white alumina ceramic at the measurement point.)	
Linearity	±3% FS	
Response time	5 ms with a white alumina ceramic object. Linearity changes according to object.  The delays are the 10% to 90% rising and falling times of the analog output in response to a sudden change in the displacement.	
Temperature characteristics	±0.3% FS/°C	
Warm-up time required	3 minutes (within 1% of stable value)	
Indicators	Stability	Stable range: Green Operating range: Not lit Dark: Red
	Range	In range: Green Out of range: Red
Outputs	Analog output	4 to 20 mA/±4 mm Load impedance: 300Ω max.
	DARK output	NPN open collector 50 mA max., 30 VDC Residual voltage: 1 V max.

## ■ CHARACTERISTICS

Power supply voltage	12 to 24 VDC±10%, max. permissible ripple: 10% peak-to-peak
Current consumption	80 mA max.
Vibration resistance	Destruction: 10 to 55 Hz (1.5-mm double amplitude, 30G max.) for 15 minutes each in X, Y, and Z directions
Shock resistance	Destruction: 50G for 3 times each in X, Y, and Z directions
Ambient temperature	Operating: -10° to 55°C (14° to 131°F) with no icing
Ambient humidity	35% to 85% (with no icing)
Enclosure rating	IP66
Weight	150 g (5.29 oz.) with 5-m (16.4 ft.) cable; 50 g (1.76 oz.) without cable
Accessories supplied	Mounting bracket, mounting screws, resistor (250 Ω, 0.5 W)

# Engineering Data

## LINEARITY CHARACTERISTICS vs. OBJECTS

Linearity characteristic curves are obtained by detecting an object at different positions within the measurement range and plotting the analog output error resulting from each operation. The LED Displacement Sensor cannot detect an object accurately if the reflection ratio of the object is extremely small (for example, a black object) or extremely large (for example, an object with a shiny surface).

### Inclined Object (Typical Example)

Angle: 0%

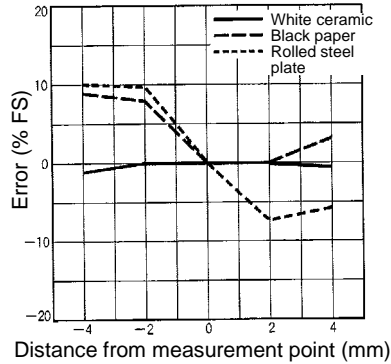

Angle: -15%

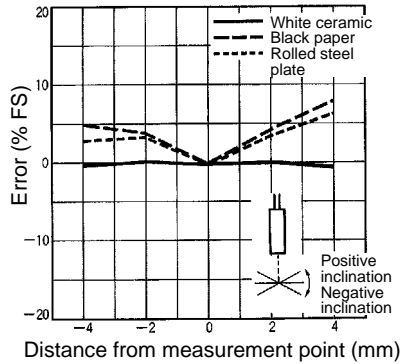

Angle: +15%

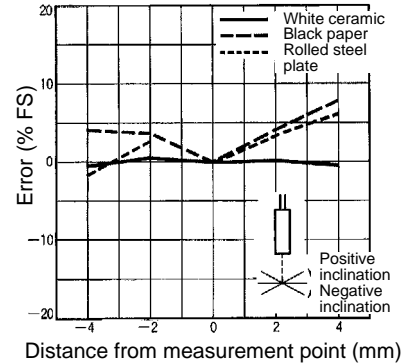

Angle: -30%

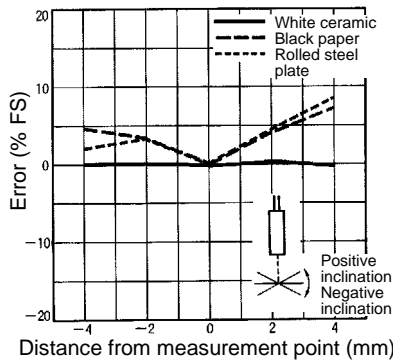

Angle: +30°

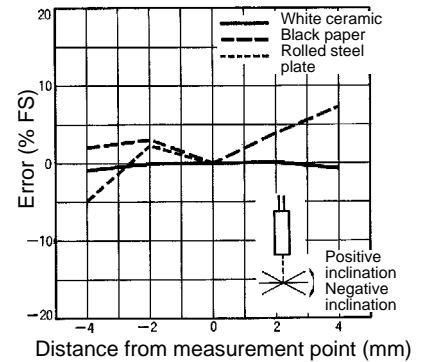

### Obliquely Positioned Object (Typical Example)

Angle: -15%

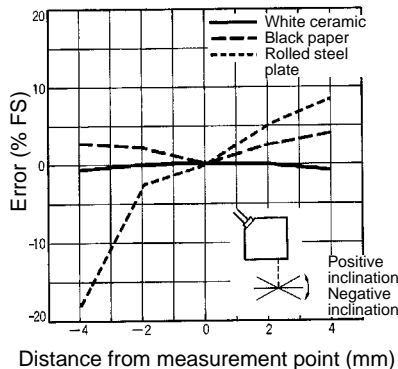

Angle: +15%

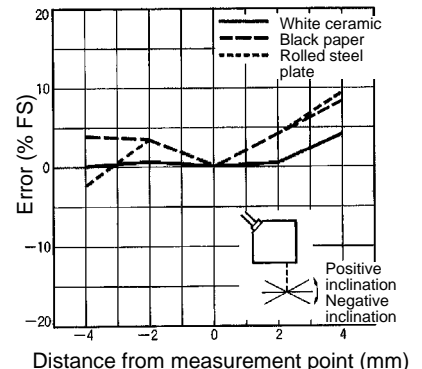

**Obliquely Positioned Object (continued)**

When installing the sensor, position the sensor correctly for the type of object to be detected. If a shiny object is positioned at a large oblique angle to the sensor, detection of the object will be difficult and may cause an inaccurate output.

**Angle: -30%**

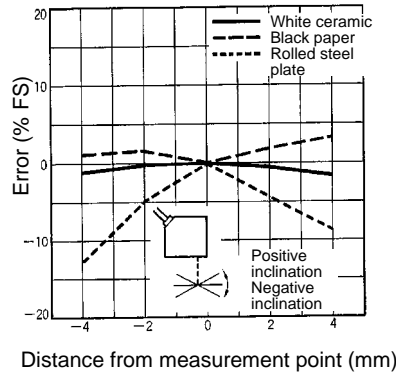

**Angle: +30%**

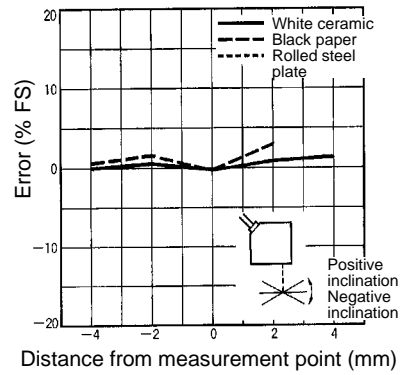

**SENSING VARIOUS OBJECTS**

**Offset Error vs. Object Material**

When detecting a variety of objects successively, refer to the offset error graph shown here. The graph illustrates changes in sensor output characteristics when black paper is compared to white paper.

To reduce the offset error value, install the Sensor so that objects are detected at (or as close as possible to) the measurement point.

**Offset Error Range (Typical Example)**

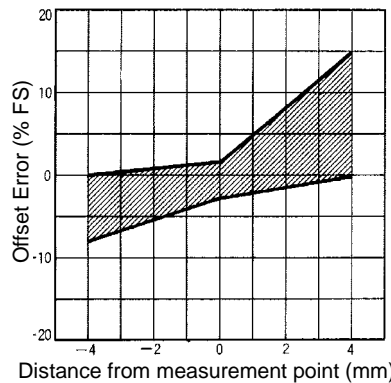

**ANGLE CHARACTERISTICS**

The angle characteristics were obtained by detecting an object with different angles of inclination at the measurement point and plotting the analog output error resulting from each operation.

The LED Displacement Sensor is designed to detect the front of an object facing the sensor. Errors occur when the object is positioned at a large oblique angle to the sensor.

**Inclined Object (Typical Example)**

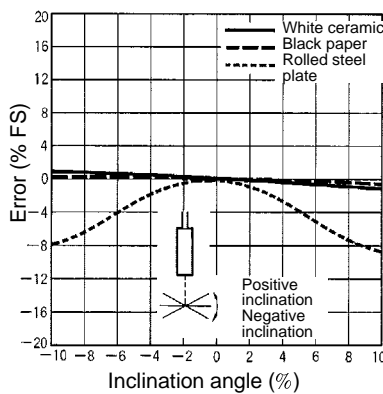

**Obliquely Positioned Object (Typical Example)**

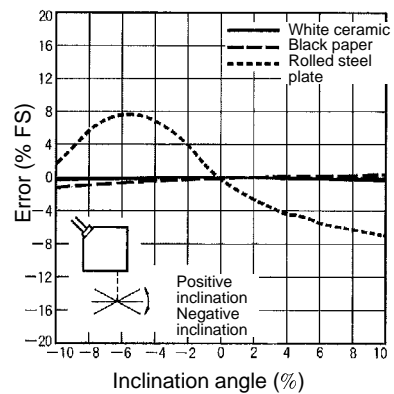

# Connections

## SENSOR CONNECTIONS

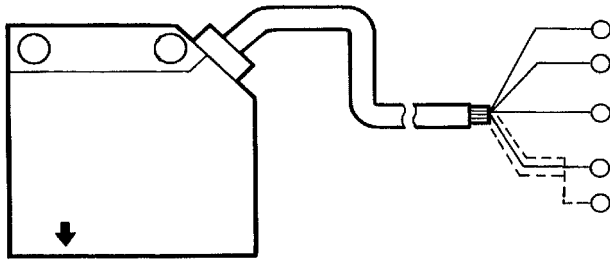

- Brown (red) 12 to 24 VDC Power supply
- Blue (black) 0 V GND
- Orange 50 mA max. at 30 VDC DARK output
- Black (white) 4 to 20 mA Analog output
- Shield \* GND

\* The two ground terminals, blue (black) and shield are internally connected. However, the blue (black) ground must be used with the brown (red) terminal for the power supply; the shield ground must be used with the black (white) terminal for the analog output.

Note: IEC wire colors shown first.

## SENSOR OUTPUT CIRCUITS

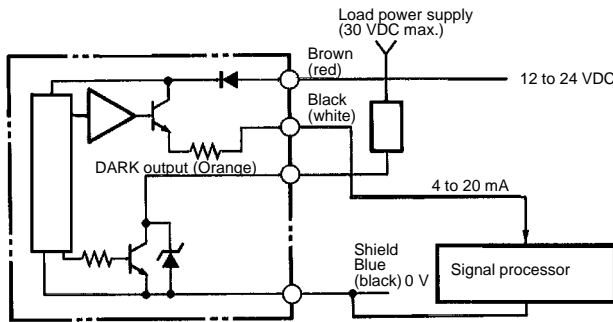

Note: IEC wire colors shown first.

## SENSOR TO Z4W-DD1C CONTROLLER

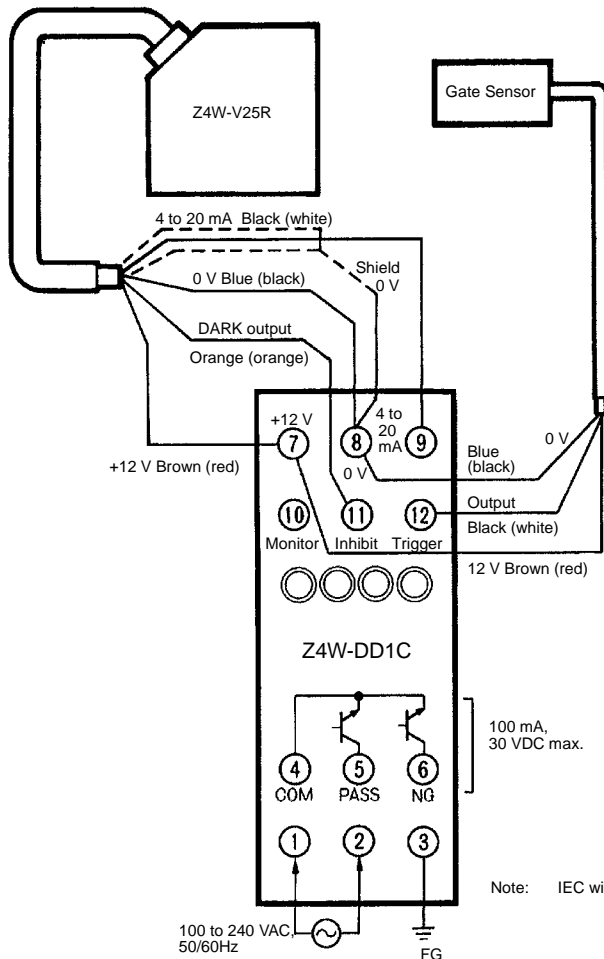

Note: IEC wire colors shown first.

## SENSOR TO S3A-DAK-US CONTROLLER

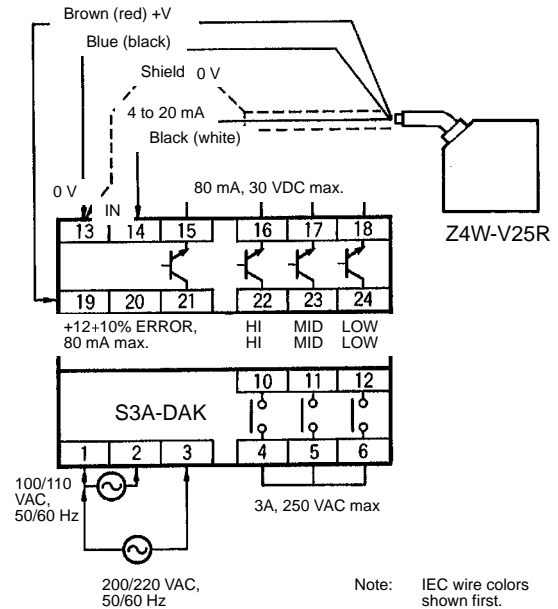

Note: IEC wire colors shown first.

■ SENSOR TO K3TX PANEL METER

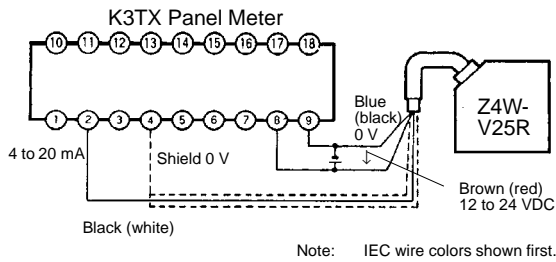

Note: Use K3TX-VD DC voltage input models.

■ SENSOR TO K3TS PANEL METER

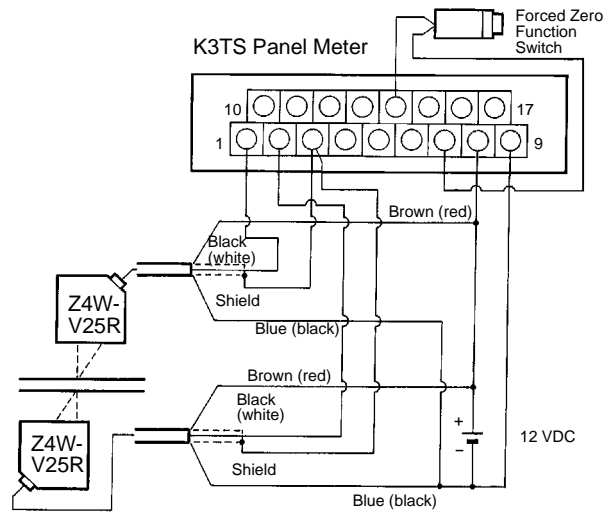

Note: IEC wire colors shown first.

Nomenclature

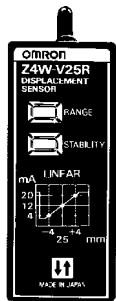

Range indicator (green/red)  
Stability indicator (green/red)

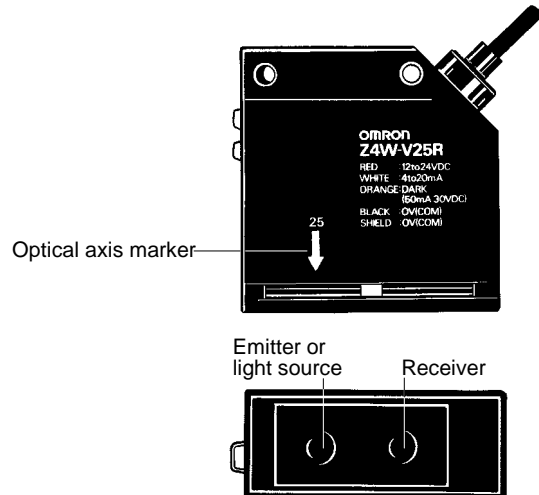

Operation

■ FUNCTIONS

Classification	Functions																
Range indicator	<p>The green indicator is lit when the object is within the measurement range. The red indicator is lit when the object is not within the measurement range.</p> <p>Note: When the intensity of the light input is insufficient (DARK output is ON and the red stability indicator is lit), the range indicator remains OFF even if the object is within the measurement range.</p> <table border="1"> <thead> <tr> <th>Distance</th> <th>Indicator</th> <th>Measurement Status</th> </tr> </thead> <tbody> <tr> <td>12 mm</td> <td>Red</td> <td>Out of the measurement range</td> </tr> <tr> <td>21 mm</td> <td>Green</td> <td rowspan="2">Inside the measurement range</td> </tr> <tr> <td>25 mm</td> <td>Green</td> </tr> <tr> <td>29 mm</td> <td>Red</td> <td rowspan="2">Out of the measurement range</td> </tr> <tr> <td>52 mm</td> <td>Red</td> </tr> </tbody> </table>	Distance	Indicator	Measurement Status	12 mm	Red	Out of the measurement range	21 mm	Green	Inside the measurement range	25 mm	Green	29 mm	Red	Out of the measurement range	52 mm	Red
Distance	Indicator	Measurement Status															
12 mm	Red	Out of the measurement range															
21 mm	Green	Inside the measurement range															
25 mm	Green																
29 mm	Red	Out of the measurement range															
52 mm	Red																

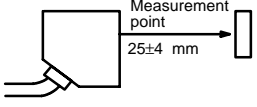
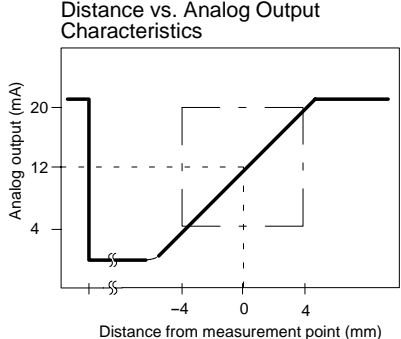
<p>Stability indicator</p>	<p>These indicators indicate the intensity of the light input. The object in the measurement range is detected when the green indicator is lit or OFF.</p> <p>The red indicator is lit when there is no object in the measurement range, or the intensity of light input is insufficient.</p> <p>If the green indicator is lit when an object is in the measurement range, the light source control circuit and light input sensitivity control circuit of the Sensor operate.</p> <p>Even if the green indicator is OFF, the Sensor works as long as the internal light source control circuit and the light input sensitivity circuit are within the operating range. At this time, the red indicator is also OFF.</p> <p>When the Sensor is active for a long duration, the green indicator may turn OFF. This does not mean that the Sensor has malfunctioned.</p>
<p>DARK output</p>	<p>The orange indicator (DARK output) is ON when there is no object in the measurement range or when the input light intensity is insufficient. The red stability indicator is also lit when DARK output is ON.</p> <p>The Sensor has an open collector output of 50 mA at 30 VDC max.</p>
<p>Analog output</p>	<p>An analog signal is output from the output line according to the sensing distance.</p> <p>Output: 4 to 20 mA/21 to 29 mm (<math>\pm 4</math> mm).</p> <p>Load impedance: 300 <math>\Omega</math> max.</p> <p>The output range lies between 20.5 and 26 mA when DARK output is ON.</p> <div style="display: flex; align-items: center;">  <div> <p>Distance vs. Analog Output Characteristics</p>  </div> </div>

## Installation

### ■ INSTALLATION (AND OPERATING ADJUSTMENTS) FOR THE SENSING HEAD (OR SENSOR)

#### Sensor Installation Procedure

Install the Sensor so that the optical axis of the Sensor and the surface of the object meet at right angles (i.e., the panel that incorporates the light source is parallel with the object). For accurate results, set the sensing distance at the measurement point, 25 mm (0.98 in).

Do not fully tighten the mounting screws until after completing the optical axis adjustment.

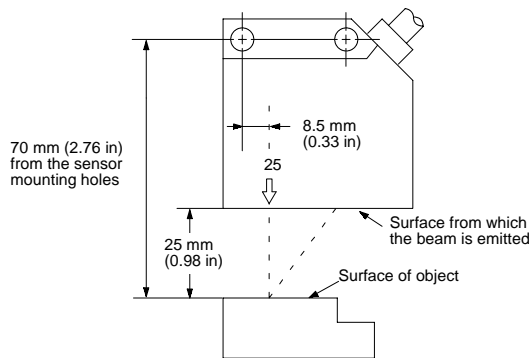

#### Wiring

Connect the Sensor to the controlling device using the sensor cable.

Follow the Sensor operating adjustments and instructions in this data sheet.

#### Axis Adjustment

When power is applied to the sensor, the red stability indicator is lit. Move the Sensor so that the red beam (see the figure below) focuses on the object. The entire light beam should be focused on the object, or an inaccurate output will result.

After the optical axis has been adjusted, tighten the mounting screws firmly.

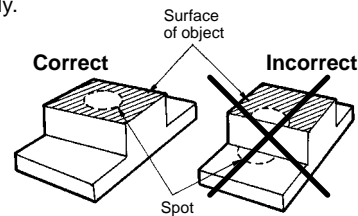

#### Conversion to Voltage Output (1 to 5 V)

The Z4W-V25R has a current output of 4 to 20 mA. With the resistor provided (250  $\Omega$ ), a voltage output of 1 to 5 V can be obtained. Refer to the figure below for connection.

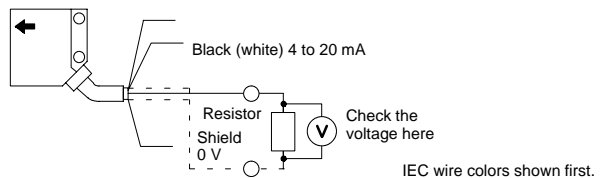

Although a resistor is included, any resistor may be used that provides a resistance of 300  $\Omega$  or less.

## ■ INSTALLATION (AND OPERATION) OF THE CONTROLLER

### Using a Z4W-DD1C Linear Sensor Controller

#### Size Discrimination

To discriminate among objects according to size, use the Z4W-V25R LED Displacement Sensor with a Z4W-DD1C Linear Sensor Controller. The two outputs provided are used in discrimination between acceptable and unacceptable parts. The timing chart included here illustrates an inspection of object height.

#### A Timing Chart for Object Height Inspection

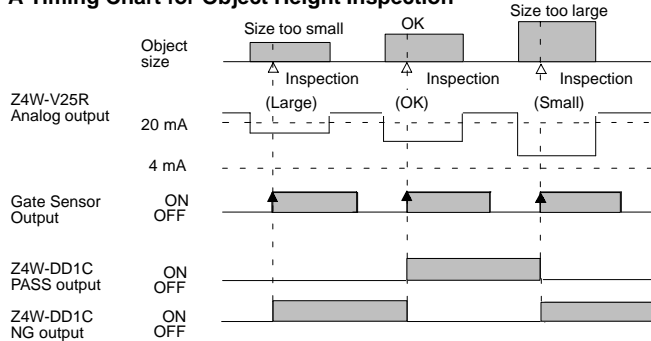

#### Required Equipment

- Z4W-V25R LED Displacement Sensor
- Z4W-DD1C Linear Sensor Controller
- Gate Sensor (E3X Fiber Optic Photoelectric Sensor or E3C-VM Miniature Head Photoelectric Sensor is recommended)
- An object of standard specified dimensions
- An object of threshold dimensions

#### Installation Procedure

Use the basic installation described previously for the *Sensor*.

When installing a gate Sensor, refer to the instruction manual and read the precautions for the model. It is important to install the gate Sensor so that the LED Displacement Sensor can detect the object at a stable measurement position. Do not tighten the mounting screws until after optical axis adjustment.

The Z4W-DD1C Linear Sensor Controller can be installed on a wall and secured with screws, or DIN-rail mounted.

#### Wiring

Make sure that the Linear Sensor Controller, the LED Displacement Sensor, and the gate Sensor are wired correctly before power-up. Refer to pages 5 and 6 for appropriate wiring connections.

Power is supplied to the LED Displacement Sensor and the gate Sensor by the Linear Sensor Controller. It is important to leave the output terminals (terminals 4, 5, 6) of the Linear Sensor Controller open at this time. (Refer to: Determining Controller Settings, found on the next page.)

#### Adjusting/Operating Linear Sensor Controller

##### Axis Adjustment

Follow this procedure:

1. Position the LED Displacement Sensor for synchronous operation with the gate Sensor.
2. Adjust the optical axis of the LED Displacement Sensor.
3. Set the position of the gate Sensor so it will detect the leading edge of the object.
4. Adjust the optical axis of the gate Sensor so that the LED Displacement Sensor detects the object at the measurement position in synchronous operation. This is important because the Linear Sensor Controller operates synchronously on receiving each output signal of the gate Sensor.

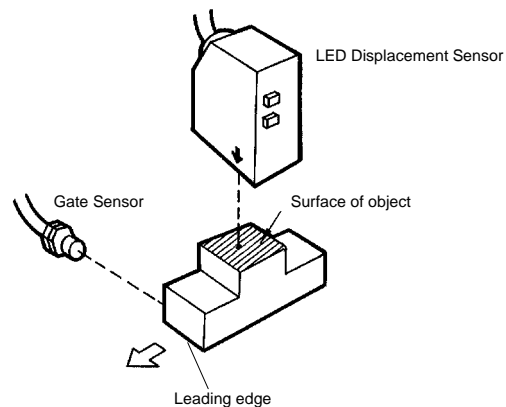

5. After adjusting the optical axis of the gate Sensor, tighten the mounting screws to secure the gate Sensor firmly.
6. Adjust the sensitivity of the gate Sensor (for models incorporating a sensitivity adjuster).



### Nomenclature

The linear sensor control panel control consists of the indicators, switches and adjusters shown below.

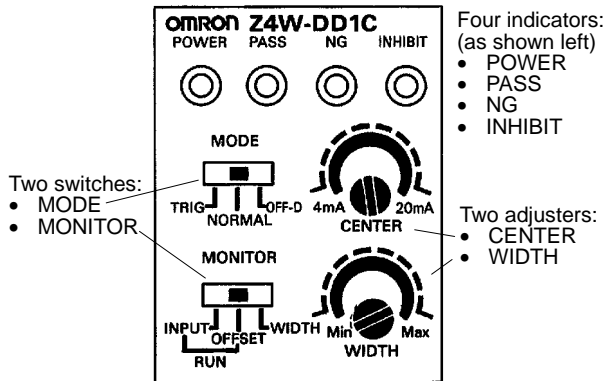

### Determine Tolerance

To determine tolerance, use either an object of threshold dimensions or a multimeter. Use the object where possible.

### Determining Controller Settings Using an Object

1. Prepare an object of threshold dimensions (an object with the allowable upper threshold dimensions or with the allowable lower threshold dimensions) to be detected by the LED Displacement Sensor.
2. Set the MODE switch to NORMAL.
3. Turn the WIDTH adjuster counterclockwise to the MIN position. The NG indicator will light.
4. Turn the WIDTH adjuster clockwise slowly to the position where the NG indicator turns OFF. The PASS indicator will light.

Set the MODE switch to TRIG as follows:

5. Set the MODE switch to TRIG.
6. Set the MONITOR switch to INPUT or OFFSET (RUN).
7. Turn OFF the power and wire the output terminals (i.e., terminals 4, 5, and 6).

### Calibrate the Sensor Controller

Using an object of the standard specified dimensions, calibrate the sensor controller as follows:

1. Set the MODE switch to NORMAL.
2. Turn the WIDTH adjuster counterclockwise to the MIN position.
3. Turning the CENTER adjuster clockwise or counterclockwise, set the adjuster to the position where the PASS indicator is lit.
4. Fine tune the controller to detect the target object. If the PASS indicator is lit for a wide range of positions, set the adjuster in the middle of the range. If the PASS indicator does not light with the CENTER adjuster in any position, turn the WIDTH adjuster clockwise slightly.

### Determining Controller Settings Using a Multimeter

Determine the absolute tolerance, A (in mm), and obtain the voltage  $V_x$  (V) as follows:

$V_x$  (V) = Monitor output voltage

$\pm W_o$  (%FS) = Tolerance

$V_x = 3 + W_o \times 1/25$

1. Set the MONITOR switch to WIDTH.
2. Check the voltage of monitor terminals 10 (positive voltage output) and 8 (negative voltage output) of the Linear Sensor Controller with the multimeter in the 10-VDC or 5-VDC range.
3. Turn the WIDTH adjuster clockwise or counterclockwise to the position where the voltage reaches  $V_x$  (obtained from the above formula).

Set the MODE switch to TRIG as follows:

4. Set the MODE switch to TRIG.
5. Set the MONITOR switch to INPUT or OFFSET (RUN).
6. Turn OFF the power and wire the output terminals (i.e., terminals 4, 5, and 6).

# Dimensions

## ■ Z4W-V SENSOR

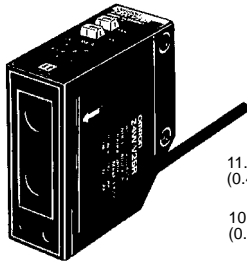

Unit: mm (inch)

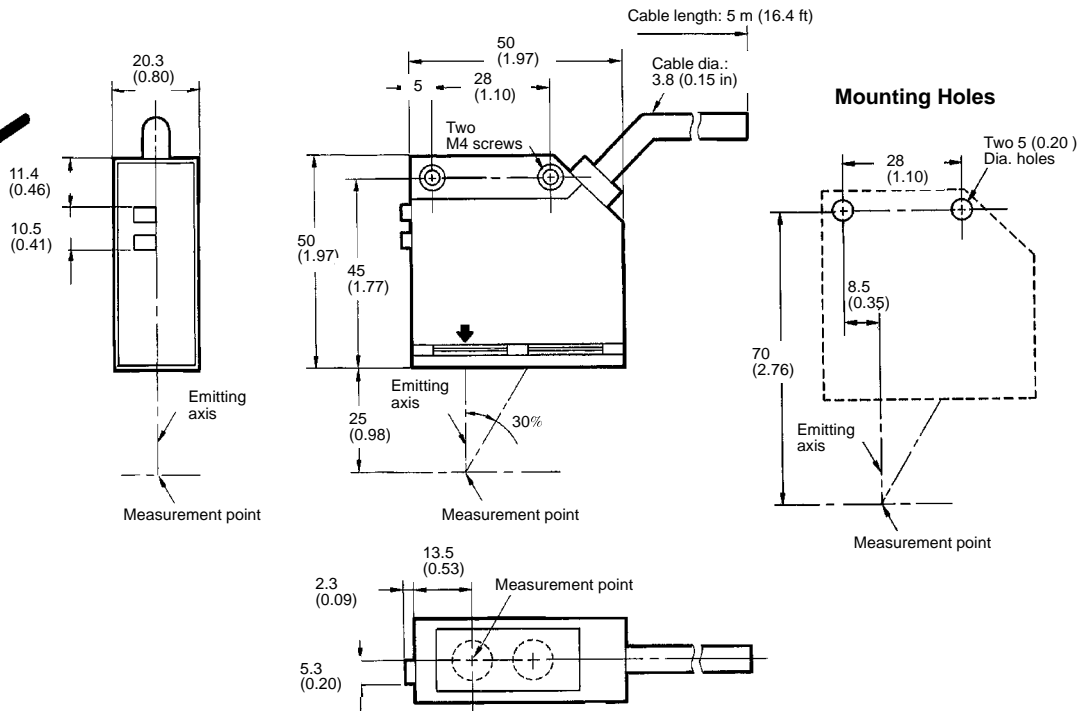

## ■ MOUNTING OPTION 1

Unit: mm (inch)

Secure the mounting bracket to the sensor side as indicated below.

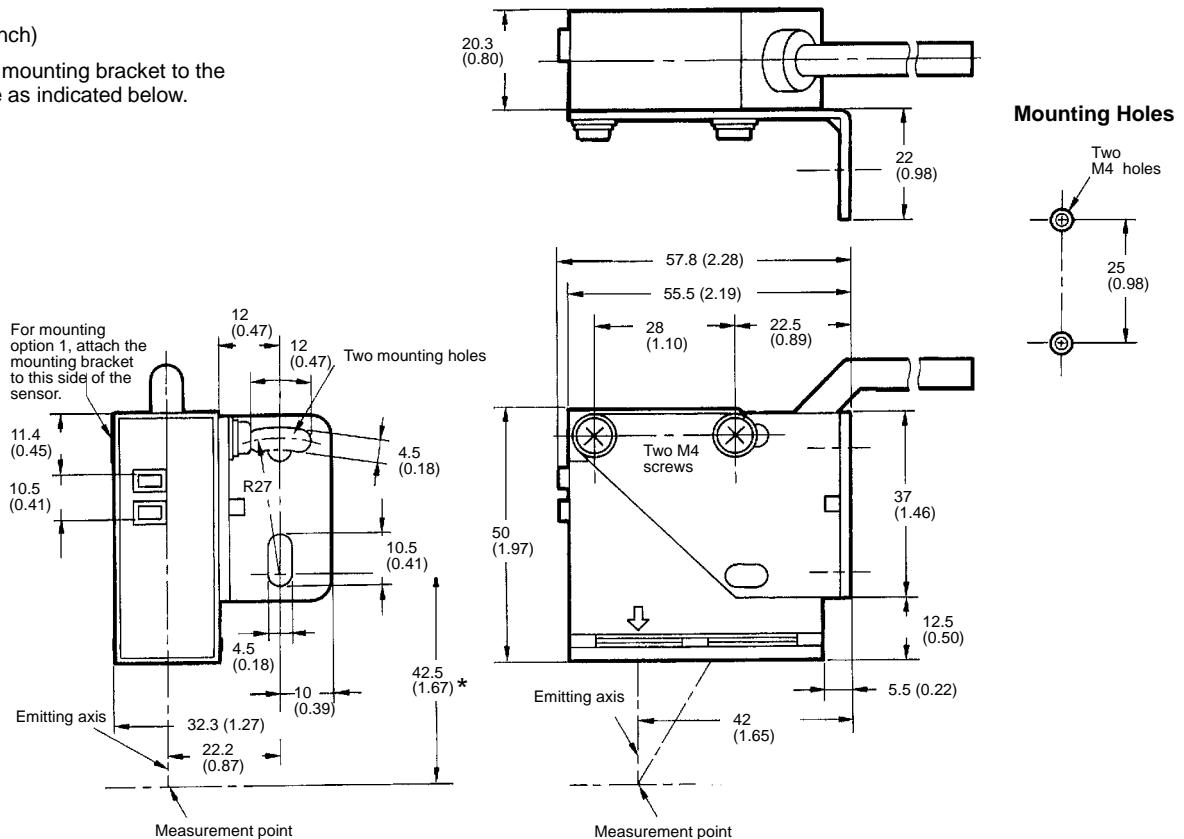

\* This distance can be extended up to 44.5 mm (1.75 in). After mounting, when this distance is 44.5 mm in length, the angle of the optical axis can be adjusted by approximately ±5° max.

## ■ MOUNTING OPTION 2

Unit: mm (inch)

Secure the mounting bracket to the sensor side as indicated here.

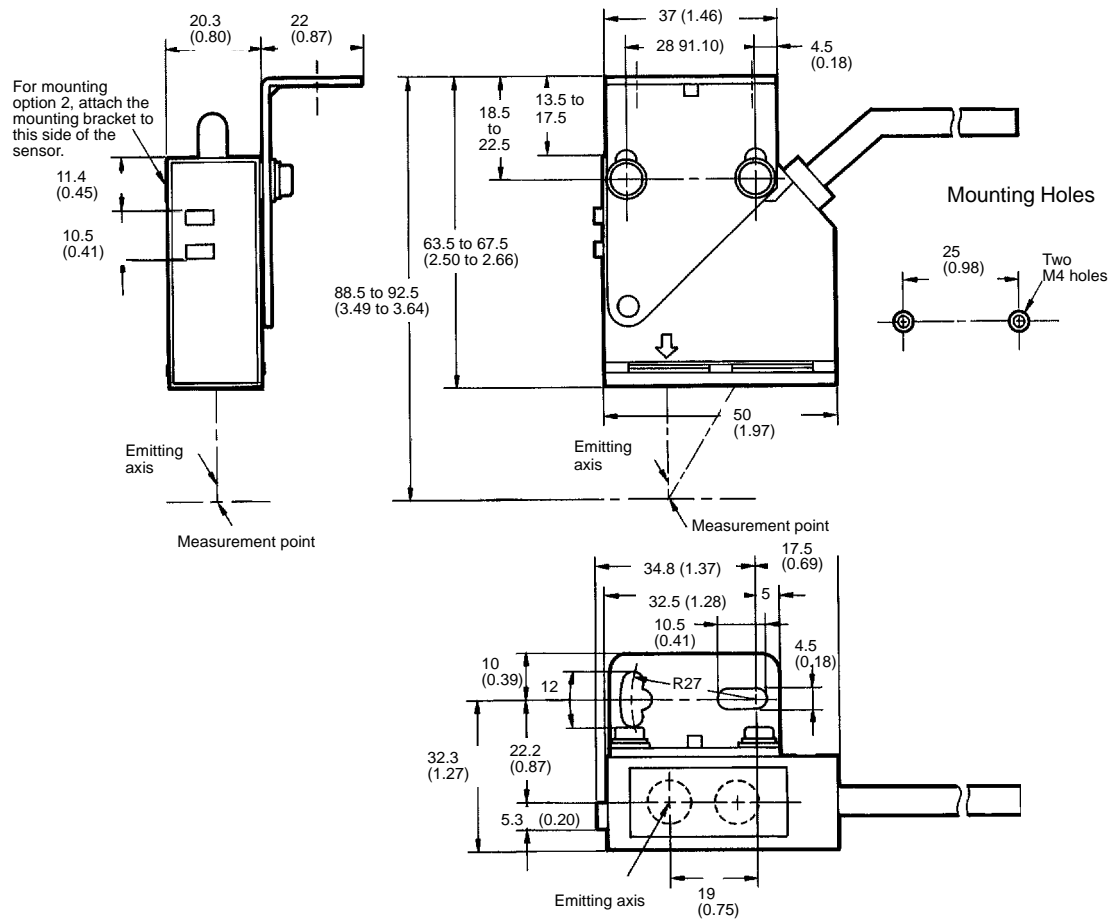

## Precautions

### ■ CLEANING

Install the Sensor in a clean environment to keep the filter (on the front of the Sensor) free from oil and dust.

If the sensor is affected by oil or dust, clean it as follows:

1. Use a blower brush (used to clean camera lenses) to blow large dust particles from the surface. Do not blow the dust away with your mouth.
2. Use a soft cloth (for lenses) with a little alcohol to remove the remaining dust. Do not use a scrubbing action when cleaning because a scratch on the filter could result in Sensor malfunction.

### ■ ENVIRONMENT

Do not use the LED Displacement Sensor in a strong electromagnetic field or in an environment where the operation of the Sensor is subjected to the reflection of intense light (such as light from a laser beam or an electric arc welding machine).

Do not use the LED Displacement Sensor to detect objects that are mirror-like, or transparent, or have an extremely small reflection ratio (i.e., either an object smaller than the diameter of the Sensor's sensing spot, or an inclined object).

### ■ WIRING

Do not wire the power supply cable for the Z4W-V25R within a conduit carrying high-voltage lines or power lines; the result would be interference, damage, or Sensor malfunction.

## ■ MUTUAL INTERFERENCE

Two Z4W-V25R LED Displacement Sensors can be installed in close proximity to each other and operate independently without interference (refer to the figures below). Do not install two sensors at an oblique angle to each other; interference may result.

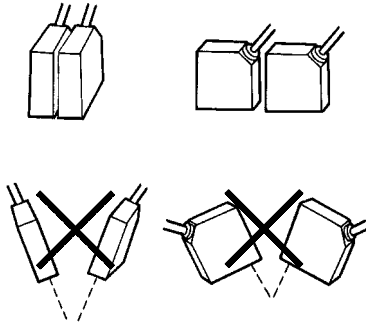

When using the LED Displacement Sensor in combination with another type of Sensor (such as a Photoelectric Sensor), the sensor beams should be as close to perpendicular as possible.

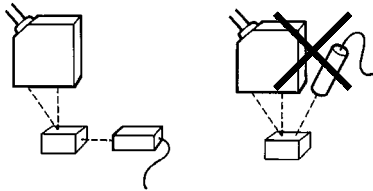

## ■ FOR A SURFACE OF VARYING MATERIALS

When the surface of the target object consists of different materials placed next to each other, the Sensor can accurately detect the object only if the Sensor is parallel to the boundary of the varied materials.

### Positioning the Sensor

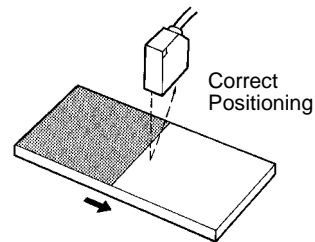
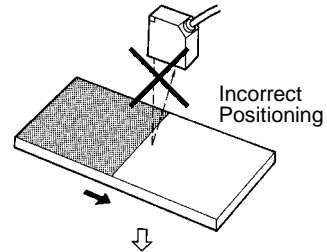

**NOTE: DIMENSIONS SHOWN ARE IN MILLIMETERS. To convert millimeters to inches divide by 25.4.**

# OMRON®

**OMRON ELECTRONICS, INC.**

One East Commerce Drive

Schaumburg, IL 60173

**1-800-55-OMRON**

**OMRON CANADA, INC.**

885 Milner Avenue

Scarborough, Ontario M1B 5V8

**416-286-6465**