

Compact Basic Switch of Ultra-low Operating Force Assures Yet Higher Contact Reliability

- Uses an internal hinge lever mechanism for ultra-low operating force and outstanding contact reliability.
- Shape is identical to that of the V Compact Basic Switches.
- Gold-alloy contact for micro-load VX-01 models.
- Conforms to EN61058-1



Ordering Information

■ Model Number Legend

VX-□□-□□□

1 2 3 4 5

1. Ratings

5: 5 A
01: 0.1 A

2. Actuator

None: Pin plunger
1: Short hinge lever
2: Hinge lever
3: Long hinge lever
4: Simulated hinge lever
5: Short hinge roller lever
6: Hinge roller lever

3. Contact Form

1: SPDT
2: SPST-NC
3: SPST-NO

4. Terminal Specifications







A: Solder/Quick-connect terminal (#187)
C2: Quick-connect terminal (#187)

5. Operating Force max.

2: OF 0.25 N {25 gf}
3: OF 0.49 N {50 gf}

Note: These values are for the pin plunger model.

■ List of Models

Actuator	Terminals (see note)	OF max.	Model	
			5 A	0.1 A
Pin plunger 	A	0.25 N {25 gf}	VX-5-1A2	VX-01-1A2
		0.49 N {50 gf}	VX-5-1A3	VX-01-1A3
	C2	0.25 N {25 gf}	VX-5-1C22	VX-01-1C22
		0.49 N {50 gf}	VX-5-1C23	VX-01-1C23
Short hinge lever 	A	0.49 N {50 gf}	VX-51-1A3	VX-011-1A3
	C2	0.49 N {50 gf}	VX-51-1C23	VX-011-1C23
Hinge Lever 	A	0.29 N {30 gf}	VX-52-1A3	VX-012-1A3
	C2	0.29 N {30 gf}	VX-52-1C23	VX-012-1C23
Long hinge lever 	A	0.20 N {20 gf}	VX-53-1A3	VX-013-1A3
	C2	0.20 N {20 gf}	VX-53-1C23	VX-013-1C23
Simulated hinge lever 	A	0.29 N {30 gf}	VX-54-1A3	VX-014-1A3
	C2	0.29 N {30 gf}	VX-54-1C23	VX-014-1C23
Short hinge roller lever 	A	0.59 N {60 gf}	VX-55-1A3	VX-015-1A3
	C2	0.59 N {60 gf}	VX-55-1C23	VX-015-1C23
Hinge roller lever 	A	0.29 N {30 gf}	VX-56-1A3	VX-016-1A3
	C2	0.29 N {30 gf}	VX-56-1C23	VX-016-1C23

Note: 1. SPST models are also available, but not listed in the above table.

2. Terminals A: Solder/Quick-connect terminals (#187)
C2: Quick-connect terminals (#187)

Specifications

■ Ratings

Rated current	Rated voltage	Non-inductive load				Inductive load	
		Resistive load		Lamp load		NC	NO
		NC	NO	NC	NO		
5 A	250 VAC	5 A		0.5 A		4 A	
	8 VDC	5 A		3 A		4 A	
	30 VDC	5 A		3 A		4 A	
	125 VDC	0.4 A		0.1 A		0.4 A	
	250 VDC	0.3 A		0.05 A		0.2 A	
0.1 A	125 VAC	0.1 A		---		---	
	8 VDC	0.1 A		---		---	
	30 VDC	0.1 A		---		---	

Note: 1. Inductive load has a power factor of 0.4 min. (AC) and a time constant of 7 ms max. (DC).

2. Lamp load has an inrush current of 10 times the steady-state current.

3. The ratings values apply under the following test conditions:

Ambient temperature: 20±2°C

Ambient humidity: 65±5%

Operating frequency: 60 operations/min

Use the Switch in the following operating range.

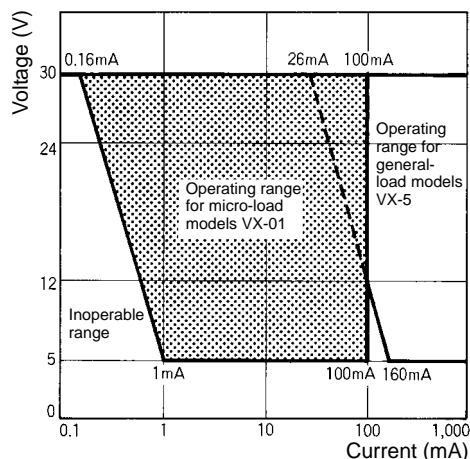

Model	VX-01	VX-5
Minimum applicable load	1 mA at 5 VDC	160 mA at 5 VDC

■ Characteristics

Item	VX-5	VX-01
Operating speed	0.1 mm to 1 m/s (at pin plunger models)	
Operating frequency	Mechanical: 600 operations/min Electrical: 60 operations/min	
Insulation resistance	100 MΩ min. (at 500 VDC)	
Contact resistance	30 mΩ max. (initial value)	50 mΩ max. (initial value)
Dielectric strength	1,000 VAC, 50/60 Hz for 1 min between terminals of same polarity 1,500 VAC, 50/60 Hz for 1 min between current-carrying metal parts and ground (see note 1) 1,500 VAC, 50/60 Hz for 1 min between each terminal and non-current-carrying metal parts	
Vibration resistance (see note 2)	Malfunction: 10 to 55 Hz, 1.5-mm double amplitude	
Shock resistance (see note 2)	Destruction: 400 m/s ² {approx. 40G} max. Malfunction: 100 m/s ² {approx. 10G} max.	
Life expectancy	Mechanical: 50,000,000 operations min. (Refer to the following <i>Engineering Data</i> .) Electrical: 500,000 operations min. (Refer to the following <i>Engineering Data</i> .)	Mechanical: 10,000,000 operations min. (Refer to the following <i>Engineering Data</i> .) Electrical: 1,000,000 operations min. (Refer to the following <i>Engineering Data</i> .)
Degree of protection	IP00	
Degree of protection against electric shock	Class I	
Proof tracking index (PTI)	175	
Ambient temperature	Operating: -25°C to 80°C (with no icing)	
Ambient humidity	Operating: 85% max. (for 5°C to 35°C)	
Weight	Approx. 6.2 g (pin plunger models)	

- Note:**
1. The value for dielectric strength shown is for models with a Separator.
 2. For the pin plunger models, the above values apply for use at both the free position and total travel position. For the lever models, they apply at the total travel position.

■ Approved Standards

UL1054 (File No. E41515)
 CSA C22.2 No.55 (File No. LR21642)

Rated voltage	VX-5	VX-01
125 VAC 250 VAC	5 A 5 A	0.1 A (Rating: 100,000 operations) ---
30 VDC	---	0.1 A (Rating: 100,000 operations)

VDE 0630 (File No. 90430)
 SEMKO (File No. 8920075)

Rated voltage	VX-5	VX-01
125 VAC	5 A	0.1 A
250 VAC	5 A	---

Note: Testing conditions: 50,000 operations, T105 (0°C to 105°C)

■ Contact Specifications

Item		VX-5 models	VX-01 models
Contact	Specification	Rivet	Crossbar
	Material	Silver alloy	Gold alloy
	Gap (standard value)	0.5 mm	
Inrush current	NC	15 A max.	---
	NO	---	---

■ Contact Form

SPDT

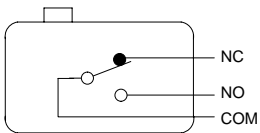

SPST-NC

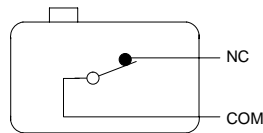

SPST-NO

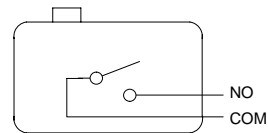

Engineering Data

Mechanical Life Expectancy (Pin Plunger)

VX-5

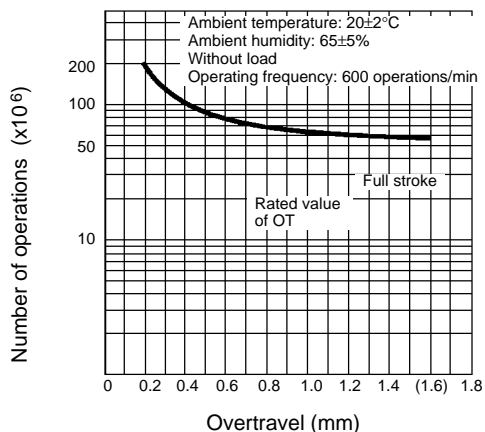

VX-01

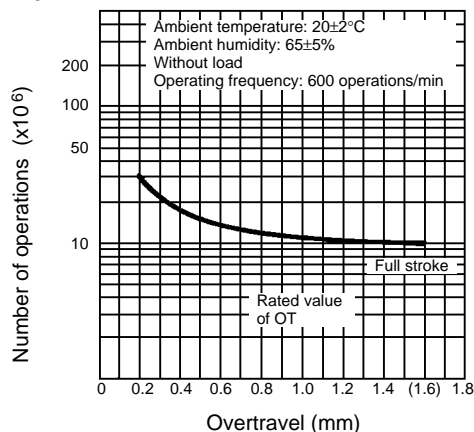

Electrical Life Expectancy

VX-5

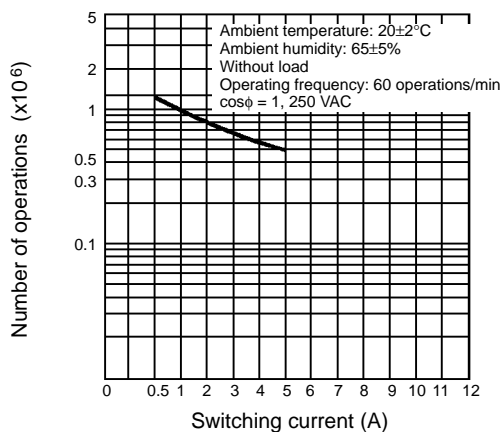

VX-01

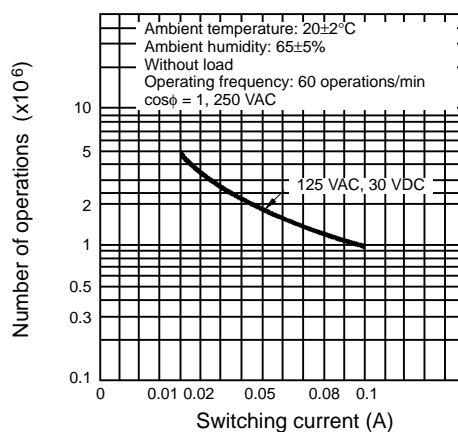

Dimensions

■ Terminals

Terminal	Solder/Quick-connect terminal (#187) (A terminal)	Quick-connect terminal (#187) (C2 terminal)
COM terminal position is bottom.	<p>Three, solder/quick-connect terminals (#187)</p>	<p>Three, quick-connect terminals (#187)</p>
Terminal dimension	<p>Note: The length to the center of the 1.6-dia. holes.</p>	

Note: The above is for the SPDT contact specifications.

■ Dimensions and Operating Characteristics

- Note:**
1. Unless otherwise specified, a tolerance of ± 0.4 mm applies to all dimensions.
 2. The following illustrations and drawings are for solder/quick-connect terminals (#187) (Terminal A). Illustrations for Terminal C2 are omitted. For details, refer to *Terminals*.
 3. The □ in the model number is for the terminal code.
 A: Solder/quick-connect terminal (#187)
 C2: Quick-connect terminal (#187)

Pin Plunger

- VX-5-1□2
- VX-5-1□3
- VX-01-1□2
- VX-01-1□3

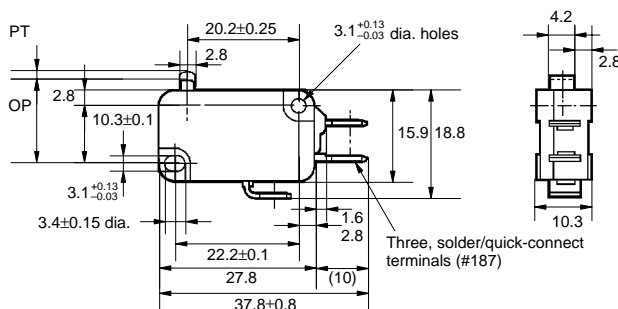
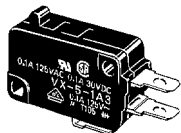

Model	VX-5-1□2	VX-5-1□3	VX-01-1□2	VX-01-1□3
OF max.	0.25 N {25 gf}	0.49 N {50 gf}	0.25 N {25 gf}	0.49 N {50 gf}
RF min.	0.03 N {3 gf}	0.05 N {5 gf}	0.03 N {3 gf}	0.05 N {5 gf}
PT max.	1.2 mm	1.2 mm	1.2 mm	1.2 mm
OT min.	1.0 mm	1.0 mm	1.0 mm	1.0 mm
MD max.	0.3 mm	0.3 mm	0.3 mm	0.3 mm
OP	14.7±0.4 mm	14.7±0.4 mm	14.7±0.4 mm	14.7±0.4 mm

Short Hinge Lever

- VX-51-1□3
- VX-011-1□3

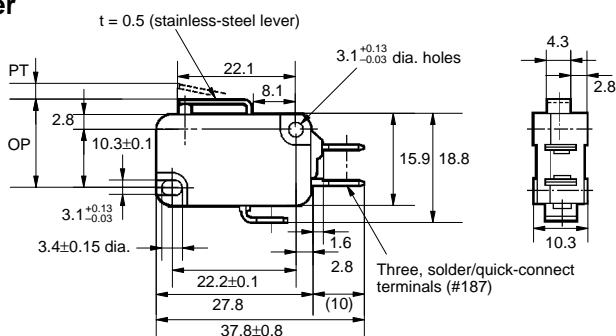
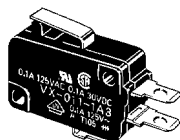

Model	VX-51-1□3	VX-011-1□3
OF max.	0.49 N {50 gf}	0.49 N {50 gf}
RF min.	0.04 N {4 gf}	0.04 N {4 gf}
PT max.	1.6 mm	
OT min.	0.8 mm	
MD max.	0.5 mm	
OP	15.2±0.5 mm	

Hinge Lever

VX-52-1□3
VX-012-1□3

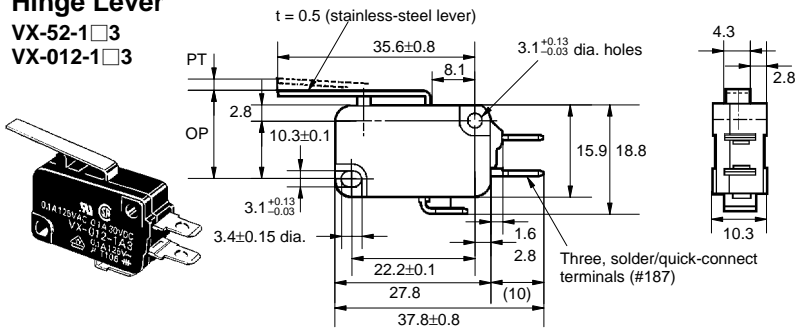

Model	VX-52-1□3	VX-012-1□3
OF max.	0.29 N {30 gf}	0.29 N {30 gf}
RF min.	---	---
PT max.	4.0 mm	
OT min.	1.6 mm	
MD max.	0.8 mm	
OP	15.2±1.2 mm	15.2±1.2 mm

Long Hinge Lever

VX-53-1□3
VX-013-1□3

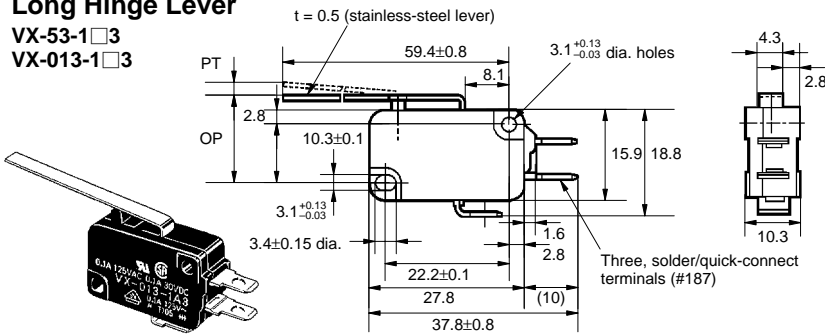

Model	VX-53-1□3	VX-013-1□3
OF max.	0.20 N {20 gf}	0.20 N {20 gf}
RF min.	---	---
PT max.	9.0 mm	
OT min.	3.2 mm	
MD max.	2.0 mm	
OP	15.2±2.6 mm	

Simulated Hinge Lever

VX-54-1□3
VX-014-1□3

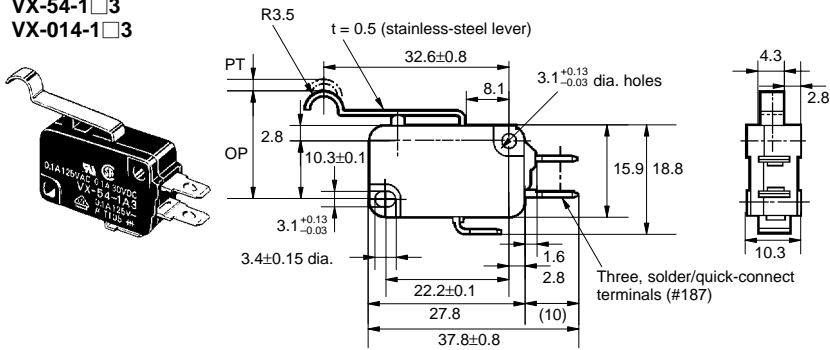

Model	VX-54-1□3	VX-014-1□3
OF max.	0.29 N {30 gf}	0.29 N {30 gf}
RF min.	0.02 N {2 gf}	0.02 N {2 gf}
PT max.	4.0 mm	
OT min.	1.6 mm	
MD max.	0.8 mm	
OP	18.7±1.2 mm	

Short Hinge Roller Lever

VX-55-1□3
VX-015-1□3

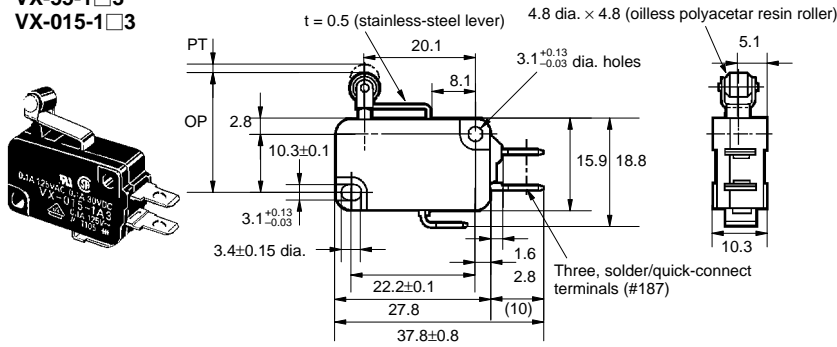

Model	VX-55-1□3	VX-015-1□3
OF max.	0.59 N {60 gf}	0.59 N {60 gf}
RF min.	0.04 N {4 gf}	0.04 N {4 gf}
PT max.	1.6 mm	
OT min.	0.8 mm	
MD max.	0.5 mm	
OP	20.7±0.6 mm	

Hinge Roller Lever

VX-56-1□3
VX-016-1□3

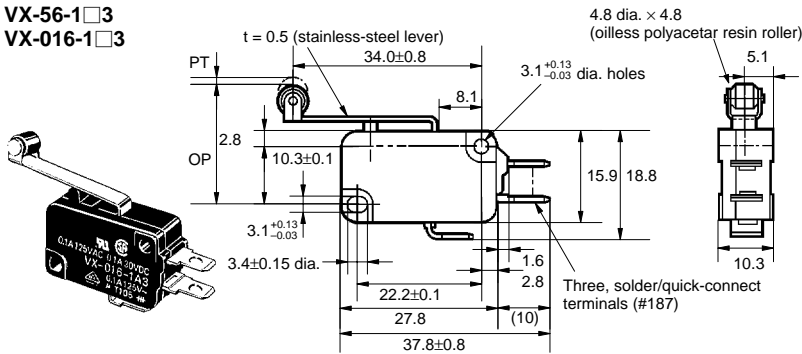

Model	VX-56-1□3	VX-016-1□3
OF max.	0.29 N {30 gf}	0.29 N {30 gf}
RF min.	---	---
PT max.	4.0 mm	
OT min.	1.6 mm	
MD max.	1.5 mm	
OP	20.7±1.2 mm	

Precautions

■ **Mounting Dimensions**

Use two M3 mounting screws with spring washers to mount the Switch. Tighten the screws to a torque of 0.39 to 0.59 N • m {4 to 6 kgf • cm}.

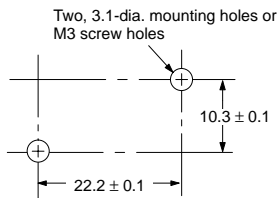

■ **Correct Use**

Refer to pages 22 to 29 for common precautions.

Handling

Be careful not to drop the Switch. Doing so may cause damage to the Switch's internal components because it is designed for a small load.

Mounting Direction

For a Switch with an actuator, mount the Switch in a direction where the actuator weight will not be applied to the Switch. Since the Switch is designed for a small load, its resetting force is small. Therefore, resetting failure may occur if unnecessary load is applied to the Switch.

Operating Temperature

Do not use the Switch under a high temperature. The thermal plastic resin used for the housing may deteriorate if exposed to a high temperature.

■ **Actuator (Sold separately)**

Various Actuators are available as shown on pages 111 to 113.

■ **Connector**

Refer to Terminal Connectors on page 214.

ALL DIMENSIONS SHOWN ARE IN MILLIMETERS.

To convert millimeters into inches, multiply by 0.03937. To convert grams into ounces, multiply by 0.03527.