

Innovate Production by Integrating Objects and Information

Read information directly marked onto objects as 2-dimensional codes. Traceability management of key parts is now possible with direct marking and reading even for small parts.

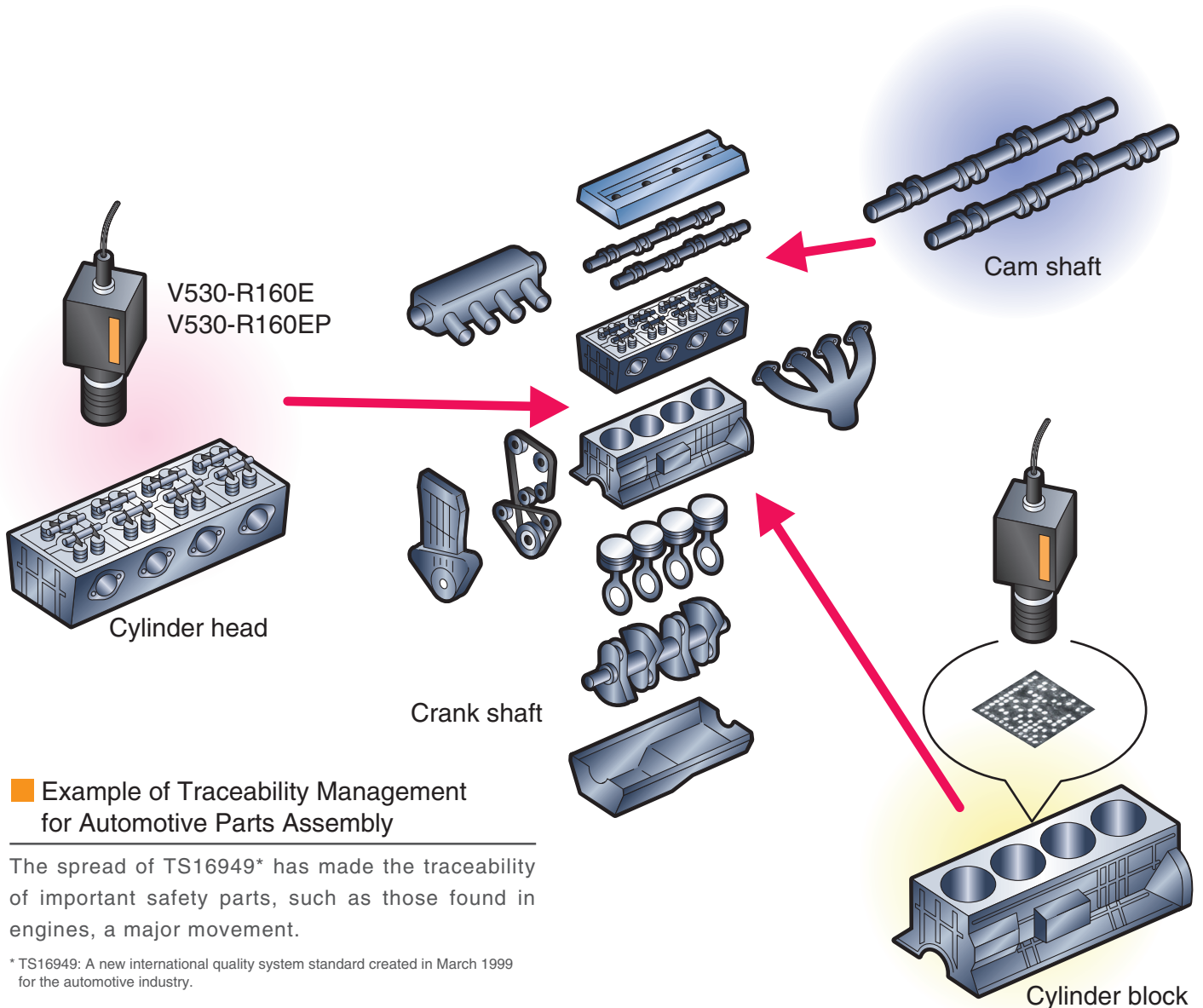

Example of Traceability Management for Automotive Parts Assembly

The spread of TS16949* has made the traceability of important safety parts, such as those found in engines, a major movement.

* TS16949: A new international quality system standard created in March 1999 for the automotive industry.

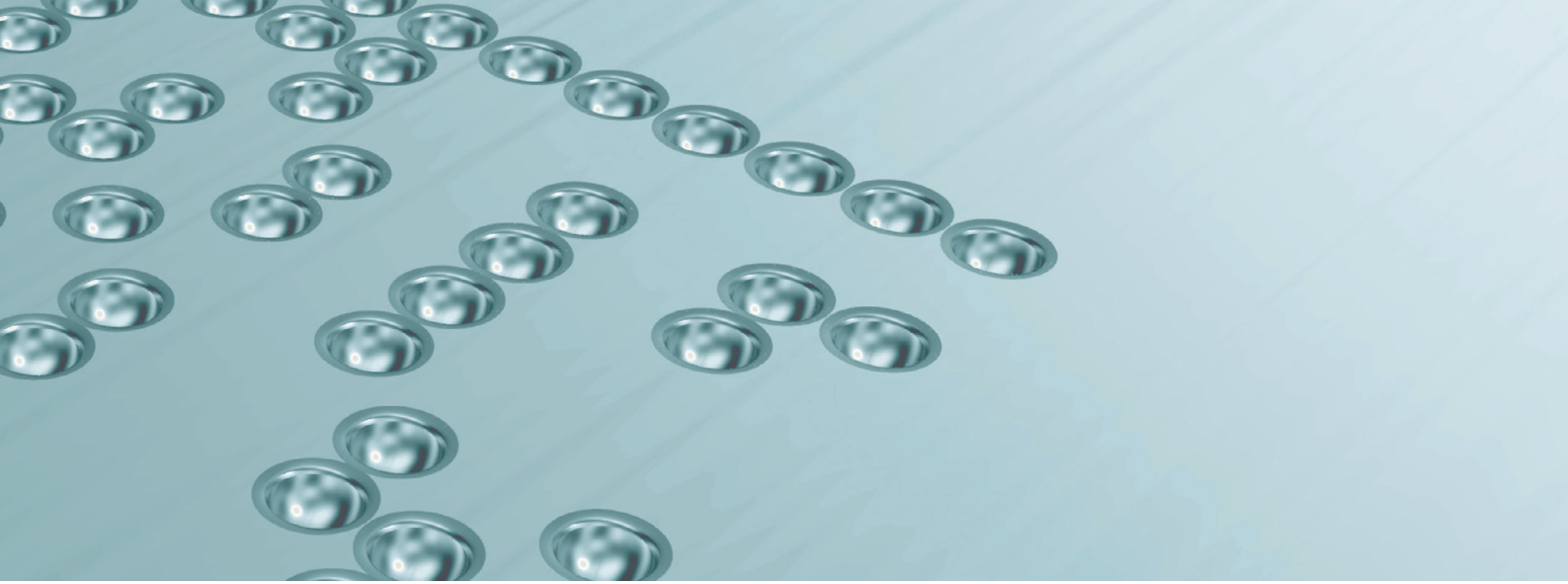

OMRON pursues direct marking, and now we provide dependable reading of 2-dimensional codes engraved on metal parts.

Dependably Read Dot Peen Markings

- Markings made by dot peen machines can be dependably read, providing the user with a wider range of selection of marking devices.
- Stable reading is possible even if the shape of cells changes because of aging in the marking device.

(Reference: Stamping using a Vector Co. dot peen machine)

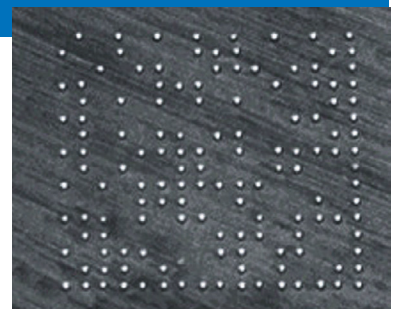

Dot Codes* Read at Any Angle: 360 Compatibility

- Codes can be read even with rough backgrounds on the casting surface or other locations.
- Dot codes* can be read at any angle through a 360 range.

* Dot codes are 2-dimensional codes in which dots form the cells.

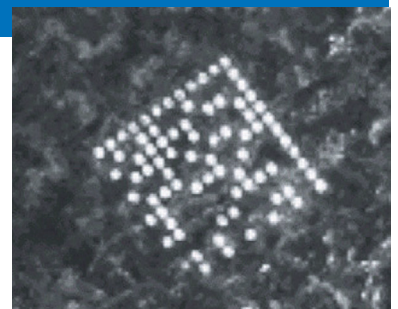
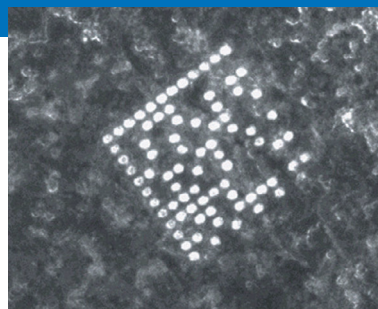

Dependably Read Markings at an Angle

- With dependable reading at an angle, installation is possible even on existing facilities with space limitations.

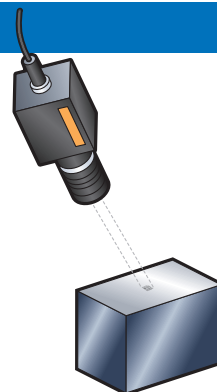



Easy Setup

Setup is easily achieved with a Memory Card (compact flash memory) slot on the V530-R160E and V530-R160EP. Just insert a card to easily copy settings or save images. Carrying a personal computer and cables is no longer required for process switchovers.



Easy Operation and Maintenance

Trends can be monitored to achieve the following:

- Displaying changes in the status (correlation values) of codes or contrast changes on line graphs on a monitor.
- Setting alarm levels while monitoring graphs.
- Outputting external alarms if a value falls below the set value.

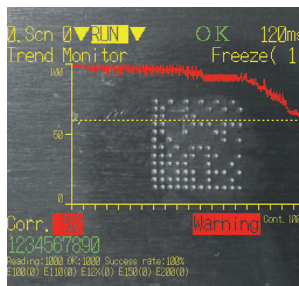

Trend monitoring can be used to set guidelines for replacing parts in lighting devices, marking devices, and other equipment.

Easy Analysis

Manage Data Histories
Histories of the number of OK and NG reads can be managed.

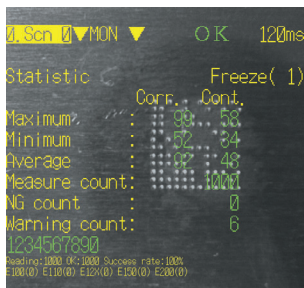

Save Images to Memory Cards
Save approx. 200 images in 64 MB and 400 images in 128 MB.

Check and Analyze Troubles
Up to 35 NG images can be saved in internal memory.

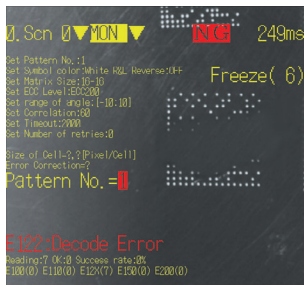

Reproduce Images
Saved NG images can be loaded to reproduce a reading.

Using time stamps on NG images with data histories enables more detailed troubleshooting.

System Configuration

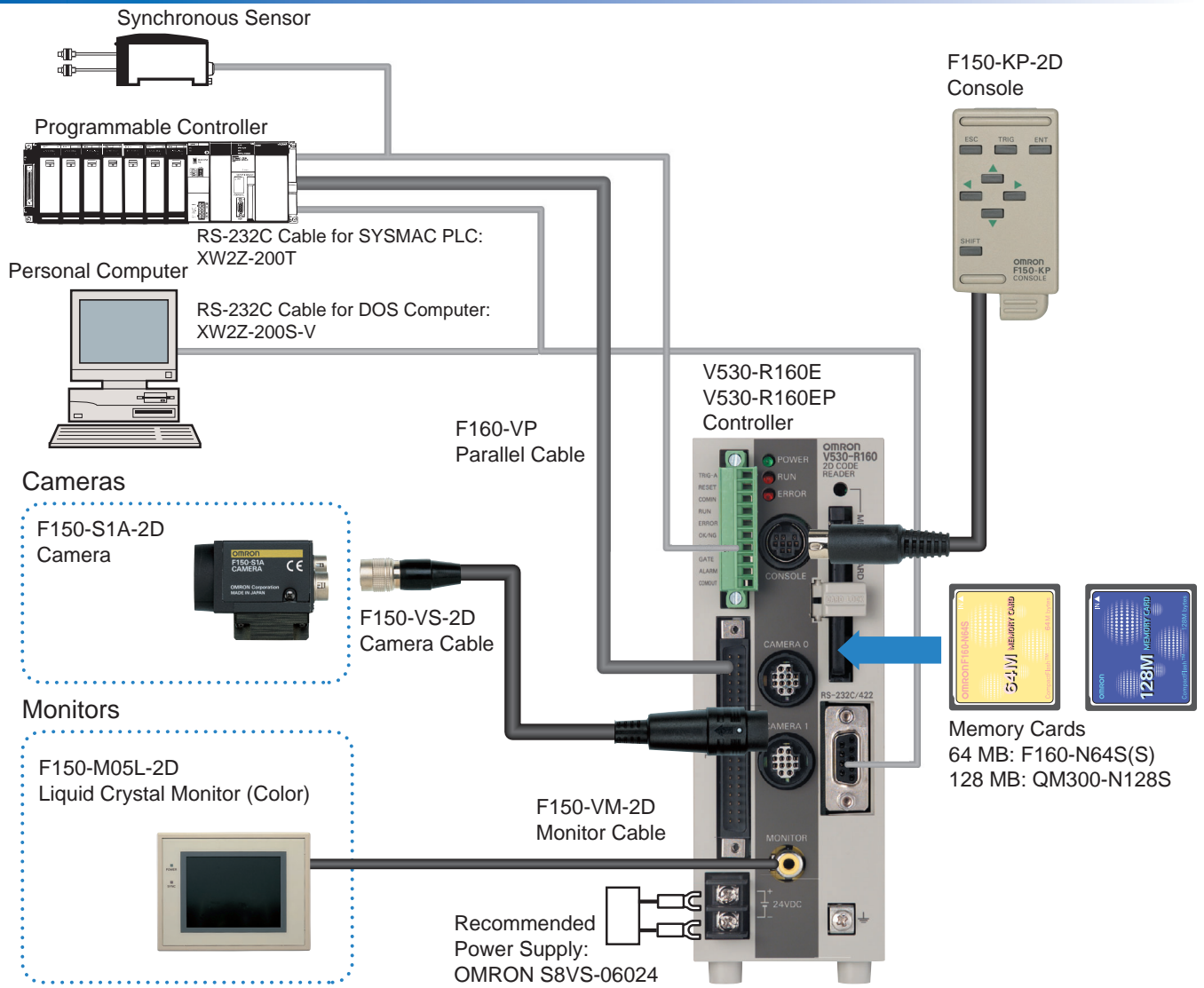

Models

Name	Model No.	Remarks
Controller	V530-R160E, V530-R160EP	
Console	F150-KP-2D	2-m cable
Camera	F150-S1A-2D	
Camera Cable	F150-VS-2D	3-m cable
Monitor Cable	F150-VM-2D	2-m cable
Liquid Crystal Monitor	F150-M05L-2D	
Parallel Cable	F160-VP	Cable with loose wires for Parallel I/O Connector (2-m cable)
Memory Card	F160-N64S(S)	Card capacity: 64 MB
	QM300-N128S	Card capacity: 128 MB
RS-232C Cable	XW2Z-200S-V	For IBM PC/AT or compatible computer (2-m cable)
	XW2Z-200T	For SYSMAC PLC (2-m cable)

Specifications

V530-R160E, V530-R160EP Controller

Item	Specifications	
Model	V530-R160E	V530-R160EP
Input/Output type	NPN	PNP
Applicable codes	Data Matrix ECC200: 10 × 10 to 64 × 64, 8 × 18, 8 × 32, 12 × 26, 12 × 36, 16 × 36, 16 × 48 Data Matrix ECC000, ECC050, ECC080, ECC100, ECC140: 9 × 9 to 25 × 25 QR Code (Model 1, 2): 21 × 21 to 41 × 41 (Version 1 to 6)	
Readable direction	360°	
Number of pixels (resolution)	512 (H) × 484 (V)	
Number of connectable cameras	2 max.	
Image memory function	Maximum of 35 images stored (internal memory in Controller).	
Operation method	Selected from menu.	
Processing method	Gray	
Memory Card slot	1	
Monitor interface	1 channel (color/monochrome)	
Serial communications	RS-232C/422A, 1 channel	
Parallel I/O	5 inputs: TRIG-A, TRIG-B, TRIG-C, TRIG-D, and RESET 6 outputs: RUN, ERROR, OK/NG, BUSY, GATE, and ALARM	
Power supply voltage	20.4 to 26.4 VDC	
Current consumption	Approx. 1.6 A max.	
Ambient temperature	Operating: 0 to 50°C, storage: -25 to 65°C (with no icing or condensation)	
Ambient humidity	35% to 85% (with no condensation)	
Weight	Approx. 570 g	

F150-S1A-20 Camera

Item	Specifications
Picture element	1/3-inch CCD
Effective pixels	659 (H) × 494 (V)
Shutter function	Electronic frame shutter Shutter speed: 1/100, 1/500, 1/2000, or 1/10000 s (menu selectable)
Ambient temperature	Operating: 0 to 50°C, storage: -25 to 60°C (with no icing or condensation)
Ambient humidity	35% to 85% (with no condensation)
Weight	Approx. 80 g

Monitor

Item	Name Model No.	Liquid Crystal Monitor F150-M05L-2D
Size		5.5 inches
Type		Liquid crystal color TFT
Resolution		320 × 240 dots
Input signal		NTSC composite video (1.0 V/75 Ω)
Power supply voltage		20.4 to 26.4 VDC
Current consumption		Approx. 700 mA
Ambient temperature		Operating: 0 to 50°C, storage: -25 to 65°C (with no icing or condensation)
Ambient humidity		Operating/Storage: 35% to 85% (with no condensation)
Weight (Monitor only)		Approx. 1 kg
Accessories		Operation manual, 4 mounting brackets

Dimensions

V530-R160E, V530-R160EP Controller

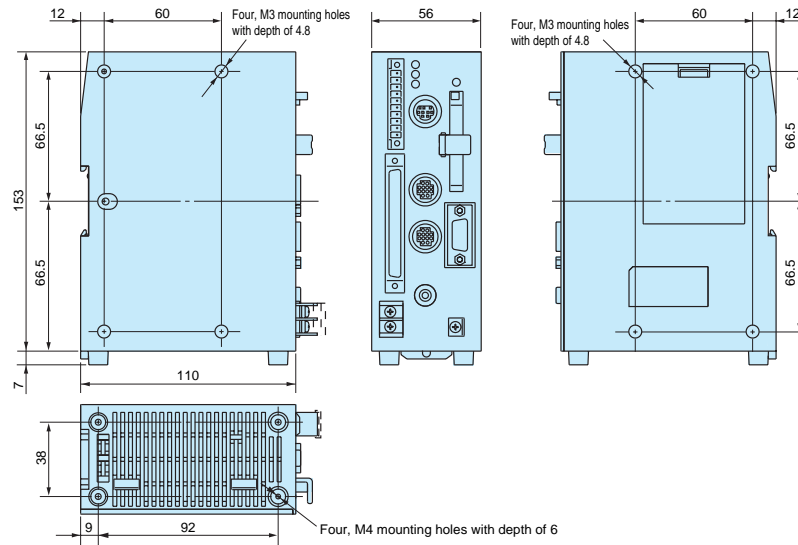

F150-S1A-2D Camera

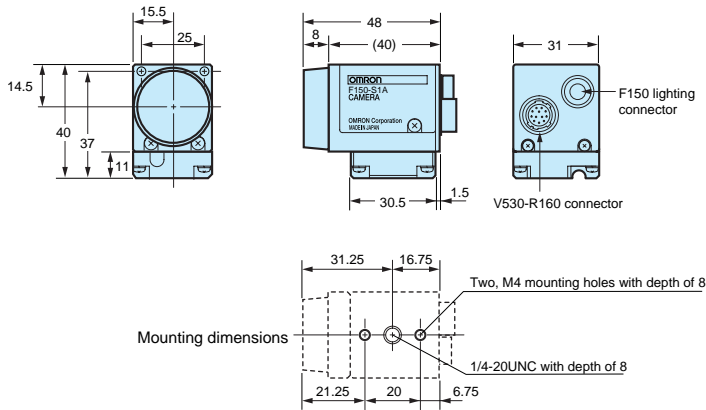

F150-KP-2D Console

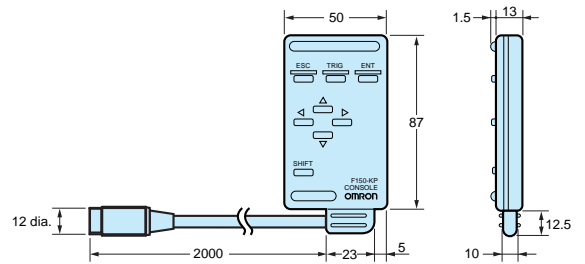

F150-M05L-2D Liquid Crystal Monitor

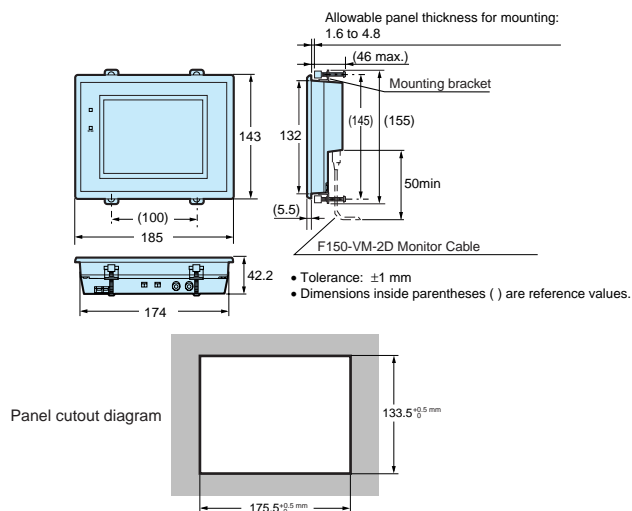

CCTV Lenses

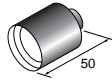
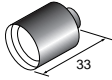
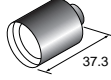
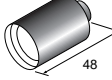
CCTV Lenses				
Model	3Z4S-LEB1214D-2	3Z4S-LEC1614A	3Z4S-LEB2514D	3Z4S-LEB5014A
Dimensions	42 dia. 	30 dia. 	30 dia. 	48 dia. 
Locking mechanism	Focus/iris locking mechanism			

Note: Refer to the following optical graph to select the Lens and Extension Tube according to the field of vision and camera mounting distance being used.

Extension Tubes

Model	Length
3Z4S-LE EX-C6	A set of six Extension Tubes that are 40, 20, 10, 5, 1, and 0.5 mm in length.

Reading the Optical Graph

The X axis of the graph shows field of vision L in millimeters, and the Y axis shows the camera mounting distance A in millimeters. (The camera mounting distance, A, is the distance from the end of the lens to the surface of the 2-dimensional code.)

The camera mounting distance A indicates the distance from the end of the lens to the surface of the 2-dimensional code, each lens is indicated by a line in the graph, and the numbers indicate the length of the Extension Tube.

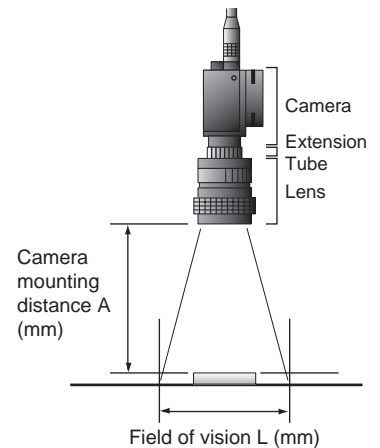

Optical Graph

Select the lens based on the field of vision and the distance (A) required between the workpieces and lens.

Brightness will decrease if the thickness of the Extension Tube is increased. If distance A is increased, the depth of field will increase.
Note: There are individual differences between Cameras. Adjust the distance when mounting the Camera.
Example: For a field of vision of 10 x 10 and a distance A of 30 mm, a 3Z4S-LEC1614A Camera with a 5-mm Extension Tube would be installed.

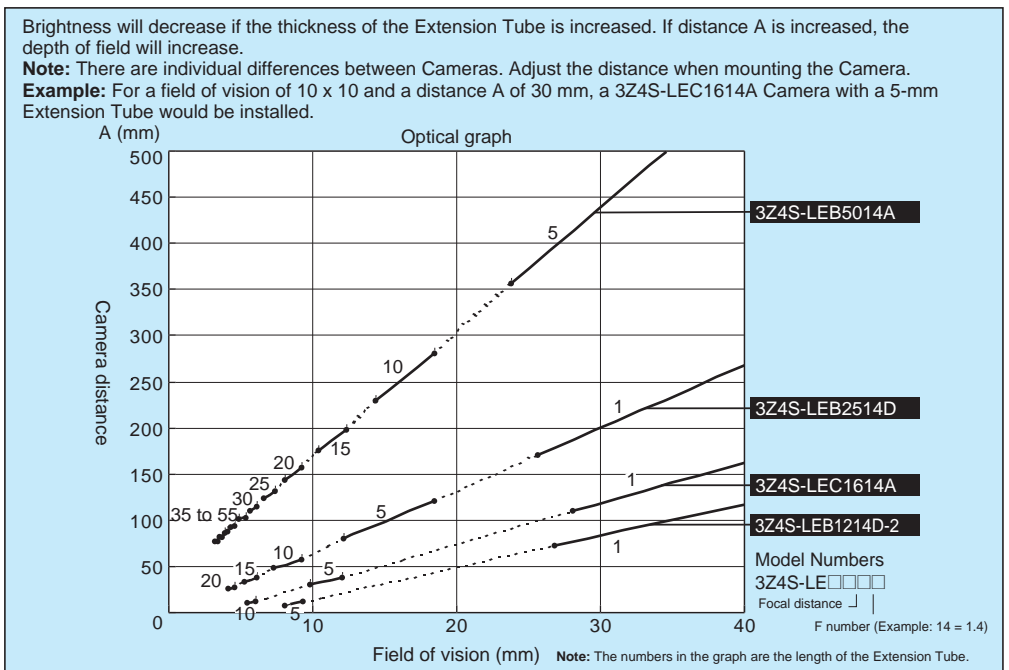

Select the appropriate lighting method for the material of the marked object.

Note: Ask your OMRON representative for models, prices, and product information.

Back Lighting

Codes on transparent objects such as glass can be read by detecting the contrast between transmitted and blocked light.

Applications: Transparent objects, such as LCD glass

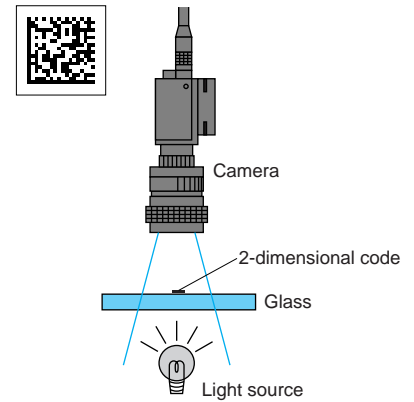

Reflected Lighting

Ring Lighting

If ring lighting is used to produce consistent lighting for markings printed on paper, rough metal parts or other light-dispersing objects, the difference in the reflection factors of the background and the marking enables stable detection.

Applications: Markings engraved on automotive parts

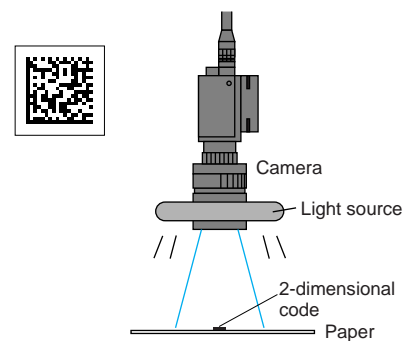

Oblique Lighting

Ring lighting close to the marked object

For codes inscribed with a laser marker onto PCBs and other relatively glossy surfaces, oblique lighting provides stable detection by distinguishing between regular and diffuse reflected light.

Applications: Direct marking on PCBs and electronic parts

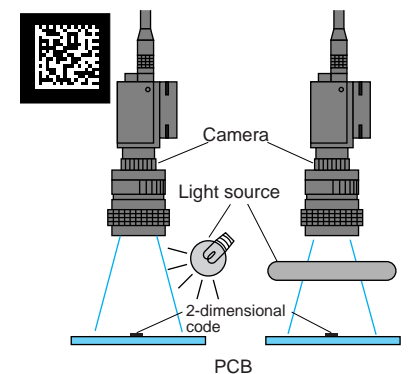

Coaxial Lighting

For codes marked directly onto wafers and other mirror-like surfaces, a stable image with few shadows from surface irregularities can be obtained from the marked object by using coaxial lighting, because it detects only regular reflected light, distinguishing it from diffuse reflected light. (The surface of the workpiece must be perpendicular to the optical axis.)

Applications: Reading codes marked on wafers and similar objects

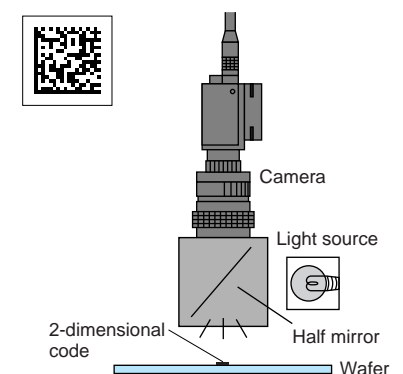

What Are 2-Dimensional Codes?

The following descriptions are based on the Data Matrix and QR Code systems, both of which use 2-dimensional codes.

Data Matrix

The Data Matrix system was developed by I.D. Matrix and is used extensively in the semiconductor and electronics industries. A Data Matrix has a relatively large data capacity for its size. There are several different types of Data Matrix, differentiated by their error correction method. The ECC200 is the most commonly used type.

QR Code

The "Quick Response Code" type is a 2-dimensional code that was developed in Japan. High-speed reading is possible with a QR Code, but the code size is quite large compared to other 2-dimensional codes.

Finder Pattern

These are patterns used to detect the position of 2-dimensional codes. The shape of the finder patterns varies with the type of code.

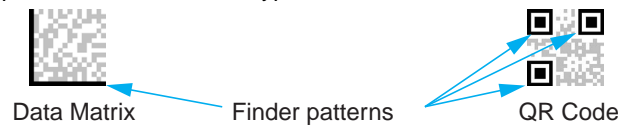

Margin (Quiet Zone)

This is the empty space around 2-dimensional codes. Usually it is necessary to ensure that there is a margin around 2-dimensional codes. The size of the required margins varies with the type of code.



Cell

These squares are the units that make up matrix-type 2-dimensional codes. Whether these cells are black or white determines the information carried by the code.

Matrix Size

The matrix size is expressed in the number of cells of which a 2-dimensional code matrix consists. (Examples: 10×10 and 12×12). The matrix size is sometimes called the code size or simply, the number of cells.

Error Correction

This term is used to describe the function which detects and corrects errors using a special mathematical technique (commonly known as the "Reed-Solomon" method). Using this function, reading is possible, to a certain extent, for codes with poor printing quality or that are damaged. There are, however, limits on the extent to which correction is possible, and reading may not be possible for codes if the damage is extensive. There are 2-dimensional codes for which the error correction level can be selected. For example, the error correction level for Data Matrix ECC200 is approximately 30% (varies with the matrix size). With a QR Code, error correction levels of 7%, 15%, 25%, and 30% are available.

Left and Right Reversal

This is the term used to describe reading 2-dimensional codes marked on a transparent material from the reverse side or reading 2-dimensional codes reflected in a mirror. For example, when a 2-dimensional code marked on glass is read from the back, left and right reversal appears.

Black and White Reversal

Usually, in images of 2-dimensional codes, the code itself is black and the background is white. Sometimes, however, due to the material of the reading object and the kind of lighting used, the code will appear white in the image obtained. This state is called "black and white reversal."

Quick-reference Tables of Data Capacities for 2-Dimensional Codes

Data Matrix ECC200

The relation between matrix size (number of cells) and data capacity is shown in the table at right. In this example, the matrix size is 12 × 12 cells.

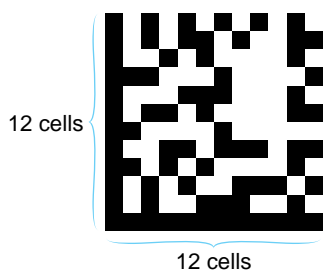

Matrix size	Maximum data capacity (See note 1.)				
	Numbers	Alphanumeric characters	Symbols	Japanese Kanji (Shift JIS)	JIS8
10 × 10	6	3	3	---	1
12 × 12	10	6	5	1	3
14 × 14	16	10	9	3	6
16 × 16	24	16	14	5	10
18 × 18	36	25	22	8	16
20 × 20	44	31	28	10	20
22 × 22	60	43	38	14	28
24 × 24	72	52	46	17	34
26 × 26	88	64	57	21	42
32 × 32	124	91	81	30	60
36 × 36	172	127	113	42	84
40 × 40	228	169	150	56	112
44 × 44	288	214	190	71	142
48 × 48	348	259	230	86	172
52 × 52	408	304	270	101	202
64 × 64	560	418	372	139	278
8 × 18	10	6	5	1	3
8 × 32	20	13	12	4	8
12 × 26	32	22	20	7	14
12 × 36	44	31	28	10	20
16 × 36	64	46	41	15	30
16 × 48	98	72	64	23	47

QR Code Model 2

The relation between matrix size (number of cells) and data capacity is shown in the table at right. In this example, the matrix size is 21 × 21 cells.

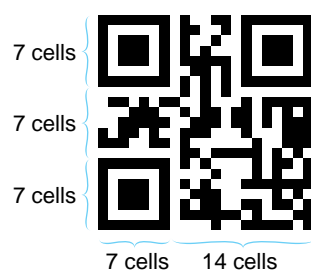

Matrix size (version) (See note 2.)	Error correction	Maximum data capacity (See note 1.)			
		Numbers	Alphanumeric characters (upper case only)	JIS8	Japanese Kanji (Shift JIS)
21 × 21 (version 1)	L (7%)	41	25	17	10
	M (15%)	34	20	14	8
	Q (25%)	27	16	11	7
	H (30%)	17	10	7	4
25 × 25 (version 2)	L (7%)	77	47	32	20
	M (15%)	63	38	26	16
	Q (25%)	48	29	20	12
	H (30%)	34	20	14	8
29 × 29 (version 3)	L (7%)	127	77	53	32
	M (15%)	101	61	42	26
	Q (25%)	77	47	32	20
	H (30%)	58	35	24	15
33 × 33 (version 4)	L (7%)	187	114	78	48
	M (15%)	149	90	62	38
	Q (25%)	111	67	46	28
	H (30%)	82	50	34	21
37 × 37 (version 5)	L (7%)	255	154	106	65
	M (15%)	202	122	84	52
	Q (25%)	144	87	60	37
	H (30%)	106	64	44	27
41 × 41 (version 6)	L (7%)	322	195	134	82
	M (15%)	255	154	106	65
	Q (25%)	178	108	74	45
	H (30%)	139	84	58	36

Note 1: Maximum Data Capacity

The maximum amount of data that can be stored in a code varies with the code size. In other words, if there is a large amount of data to be stored, then the code size must also be large. The maximum data capacity will also vary with the type of characters used. With a QR Code or Data Matrix, the numeric capacity (numbers only) is larger than the alpha numeric capacity (numbers and letters), which is in turn larger than the Japanese Kanji (Shift JIS) capacity. The order and combinations of different characters also affects the data capacity.

Note 2:

The matrix size of a QR Code is indicated by the version. "Version 1" indicates that a QR Code contains (the minimum) 21 cells both horizontally and vertically. The larger the version number, the larger the number of cells per side.

General Precautions

This brochure contains mainly information required to select models. It does not contain application precautions. Always read the application precautions and other information in the operation manual before using the product.

The application examples given in this brochure are for reference only. Confirm the functions, capacities, and safety requirements of all devices and equipment before actual application.

Consult your OMRON representative before using the product under conditions that are not described in this brochure or applying the product to nuclear control systems, railroad systems, aviation systems, vehicles, combustion systems, medical equipment, amusement machines, safety equipment, and other systems, machines, and equipment that may have a serious influence on lives and property if used improperly.

Make sure that the ratings and performance characteristics of the product are sufficient for the systems, machines, and equipment, and be sure to provide the systems, machines, and equipment with double safety mechanisms.

This document provides information mainly for selecting suitable models. Please read the Instruction Sheet or Manual for information that the user must understand and accept before purchase, including information on warranty, limitations of liability, and precautions.

OMRON

OMRON Corporation **Industrial Automation Company**

Sensing Devices Division H.Q.
Application Sensors Division
Shiokoji Horikawa, Shimogyo-ku,
Kyoto, 600-8530 Japan
Tel: (81)75-344-7068/Fax: (81)75-344-7107

Regional Headquarters

OMRON EUROPE B.V.
Sensor Business Unit,
Carl-Benz-Str. 4, D-71154 Nufringen,
Germany
Tel: (49)7032-811-0/Fax: (49)7032-811-199

OMRON ELECTRONICS LLC
1 East Commerce Drive, Schaumburg, IL 60173
U.S.A.
Tel: (1)847-843-7900/Fax: (1)847-843-8568

OMRON ASIA PACIFIC PTE. LTD.
83 Clemenceau Avenue,
#11-01, UE Square,
239920 Singapore
Tel: (65)6835-3011/Fax: (65)6835-2711

OMRON (CHINA) CO., LTD.
Room 2211, Bank of China Tower,
200 Yin Cheng Road (M),
Shanghai, 200120 China
Tel: (86)21-5037-2222/Fax: (86)21-5037-2200

Authorized Distributor: