

Compact device for easy monitoring of power consumption.

- Allows easy, energy-efficient, precise management of each device.
- Can be combined with a PLC to form a power monitor system.
- Unit for pulse output is set using a rotary switch.
- Wiring is simple with a special separable current transformer.
- Slim body – 30 mm wide.
- Conforms to EMC standards, EN61010-1 (IEC61010-1).
- UL/CSA approved. (KM20 Power Sensor only.)

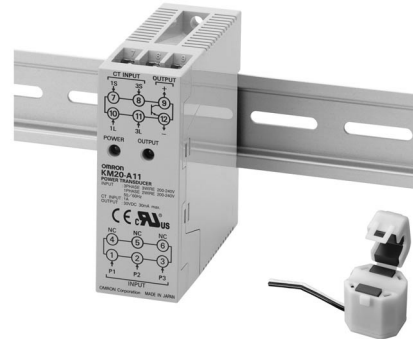

Ordering Information

System	Measurement	Input			Output	Model
		Voltage	Current	Connectable CT (See notes.)		
Single-phase, 2-wire or 3-phase, 3-wire	Integrated Power	200 to 240 VAC	50 A (Primary current of CT)	Special CT KM20-CT050-CE	1 Transistor (NPN open collector)	KM20-A11
			1 A (Secondary current of CT)	Commercially available CT (See note.)		KM20-A12

- Note:**
1. Use a commercially available current transformer that has a rating of 1 A for secondary current and a rated load of 1 VA min.
 2. Two Current Transformers are required for 3-phase, 3-wire operation.

Model Number Legend:

KM20-A

1 2

1. System/Voltage

- 1: Single-phase, 2-wire/3-phase, 3-wire, 200 to 240 VAC

2. Current Transformer to be Connected

- 1: Special Current Transformer (KM20-CT050-CE)
 2: Commercially available current transformer

■ Accessory (Order Separately)

Name	Model
Special Current Transformer (Separable)	KM20-CT050-CE

■ Special Current Transformer, KM20-CT050-CE

Rated current on primary side	50 A
Rated frequency	50 Hz/60 Hz
Overcurrent capacity	120% (continuous)
Output linearity precision	±1% (In), ±1.5% (0.2 In), ±3% (0.05 In)
Rated load	30 mVA (RL = 75 Ω)
Insulation resistance	100 MΩ min. (at 500 VDC) between core and output lead wire
Dielectric withstand voltage	2,000 VAC for 1 minute (between through-hole and output lead wire)
Cable length	1 m
Through-hole	10 mm (diameter)
Operating temperature range	-10 to 55°C (with no icing)
Storage temperature range	-25 to 60°C (with no condensation)
Approved standards	EN61326, EN61010-1/IEC61010-1 pollution degree 2, overvoltage category II
Weight	Approx. 65 g

Nomenclature

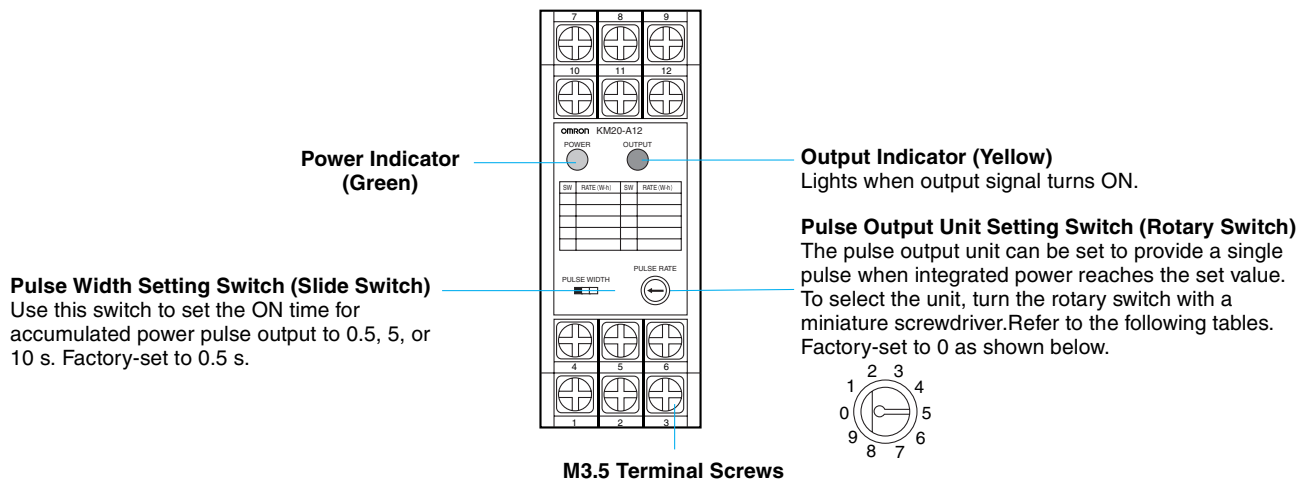

Pulse Output Unit Settings

(Unit: Wh)

Power Sensors with Special Current Transformer KM20-CT050-CE

Position of rotary switch	0	1	2	3	4	5	6	7	8	9
KM20-A11	5	10	50	100	500	1k	5k	10k	50k	100k

Power Sensors with Commercially Available Current Transformer

Position of rotary switch	0	1	2	3	4	5	6	7	8	9
KM20-A12	0.1	0.5	1	5	10	50	100	500	1k	5k

Installation

■ Connections

Terminal Arrangement

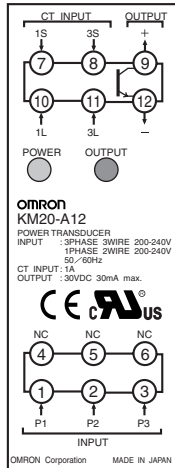

- 1 to 3: Voltage input terminals
Terminals 1 and 2 are also power supply input terminals.
- 4 to 6: NC (Unused terminals)
- 7 and 10: Input terminals 1 for current transformer
- 8 and 11: Input terminals 3 for current transformer
- 9 and 12: Output terminals

Connections Examples

Three-phase, Three-wire System

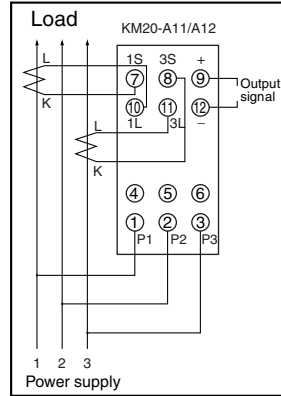

Single-phase, Two-wire System

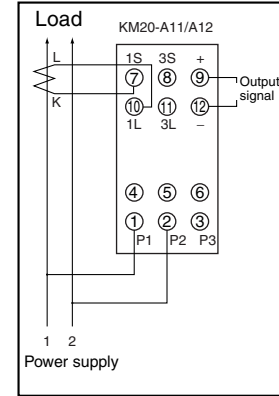

- Note:**
1. Connect the current transformer with the correct polarity. Do not reverse K and L. If the current transformer is connected with the wrong polarity, the power indicator will flash. With the KM20-CT050-CE Current Transformer, K is white and L is black.
 2. Refer to *Precautions* when applying EN and UL/CSA standards.

■ Settings

Setting the Pulse Output Unit

The pulse output unit can be set to provide a single pulse when the primary side of the Current Transformer reaches any desired set value.

The pulse output unit setting method varies depending on the KM20 and Current Transformer being used. See the note below for details on the relationship between the output pulse period and output pulse width.

1. KM20-A11 Power Sensor with Special Current Transformer:

The primary power to the CT can be used as it is, without applying a scaling factor.
To output a pulse for every 1 kW, for example, set the rotary switch to setting 5 (1 kWh).

2. KM20-A12 Power Sensor with Commercially Available Current Transformer:

The output pulse unit can be found by dividing the power per pulse by the Current Transformer Ratio.
If the Current Transformer being used has a ratio of 100/1 A (CT ratio = 100), the calculation will be as follows:
 $1,000 \text{ Wh}/100 = 10 \text{ Wh}$
The rotary switch will then be set to 10 Wh (position 4).

Setting the Period of Output Pulses

The period of the output pulses is different for single-phase systems and 3-phase systems.

1. KM20-A11 Power Sensors with Special Current Transformers:

Single-phase:
Period of output pulses (s) = $3,600 \text{ (s)} / (\text{Input power} / \text{Pulse output unit})$

Three-phase:

$$\text{Period of output pulses (s)} = 3,600 \text{ (s)} / \{ (\text{Input power} \times \sqrt{3}) / \text{Pulse output unit} \}$$

Example: With single-phase, 3-wire system, input power of 10 kW, and a pulse output unit of 50 Wh
If 10 kW of power is input continuously for 1 hour, 10 kWh will result after 1 hour (3,600 s). If the set pulse unit is 500 Wh, 20 pulses will be output in 1 hour. Thus, 1 pulse is output every 180 s, as shown in the following illustration.

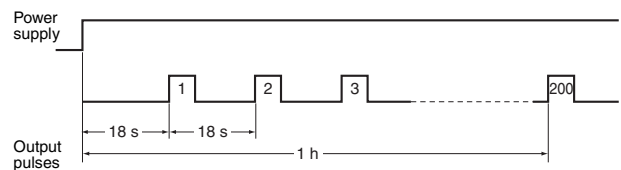

2. KM20-A12 Power Sensors with Commercially Available Current Transformers:

Single-phase:
Period of output pulses (s) = $3,600 \text{ (s)} / \{ \text{Input power} / (\text{Pulse output unit} \times \text{Current Transformer ratio}) \}$

Three-phase:

$$\text{Period of output pulses (s)} = 3,600 \text{ (s)} / \{ (\text{Input power} \times \sqrt{3}) / (\text{Pulse output unit} \times \text{Current Transformer ratio}) \}$$

Example: With the 3-phase, 3-wire, if the Current Transformer ratio is 100, the input power is 10 kW, and the pulse output unit is 1 Wh,

$$\text{Period of output pulses} = 3,600 \text{ (s)} / \{ (10 \text{ kW} \times \sqrt{3}) / (1 \times 100) \} \approx 20 \text{ s.}$$

Note If the period is shorter than the set pulse width, or if the output turns ON again immediately after turning OFF, pulse output will turn (or remain) OFF for 100 ms.

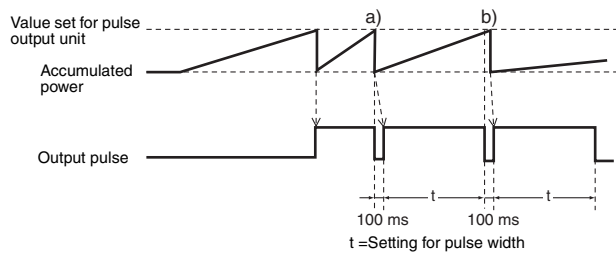

- a). The accumulated power reaches the pulse output unit while the output pulse is ON.
- b). The accumulated power reaches the pulse output unit immediately after the output pulse turns OFF.

If the OFF time is too short, there is a possibility of counting errors. In this case, change the pulse output unit to a more appropriate setting.

Dimensions

KM20-A11/KM20-A12

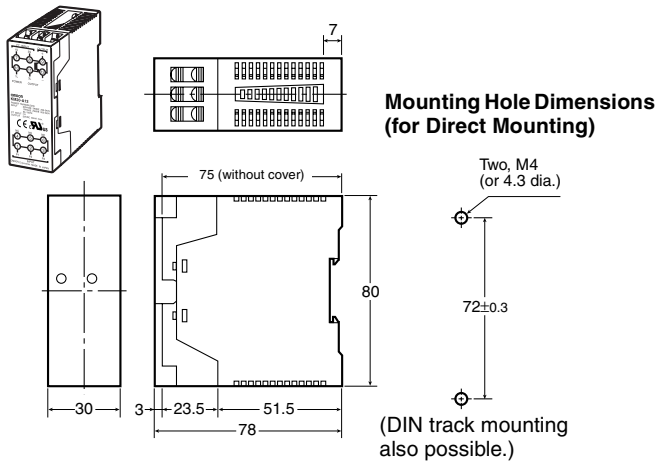

KM20-CT050-CE

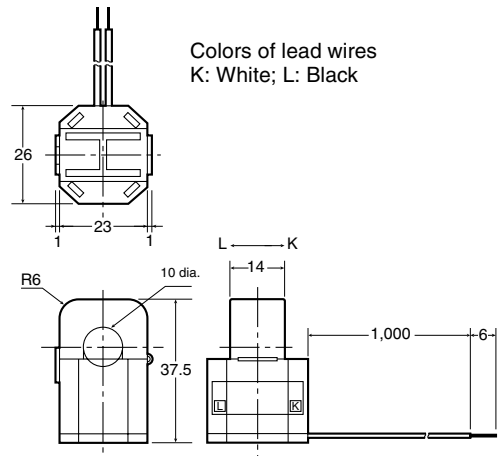

Application Examples

Electric Power Management in Combination with a PLC

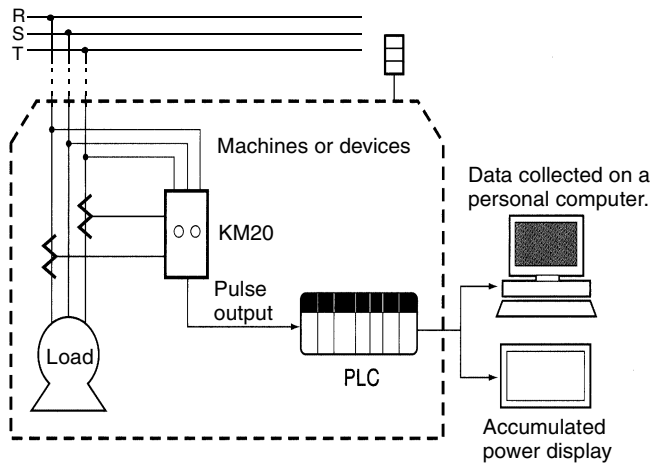

By inputting the KM20 pulse output to a PLC configured for machine control, the electric power used by each machine can be displayed and sent to a personal computer for data collection.

This makes it possible to identify and analyze the power unit requirement for each line, and each machine.

Precautions

⚠ Caution

Installation and wiring must be performed by qualified personnel. Incorrect installation or wiring may result in electric shock or injury.

⚠ Caution

Be sure to perform mounting and connection properly. Using the KM20 incorrectly mounted or connected may result in operation failure, burning, or incorrect operation.

⚠ Caution

Tighten terminal screws securely to a tightening torque between 0.69 and 0.88 N·m. Loose screws may result in fire.

⚠ Caution

Do not touch any of the terminals. Doing so may result in electric shock.

⚠ Caution

Do not attempt to take the KM20 apart or touch any internal parts while the power is being supplied. Doing so may result in electric shock.

Operating Environment Precautions

Do not use the product in locations subject to the following:

1. Shock or vibration
2. Volatile, flammable, corrosive, or toxic gas.
3. Strong electric or magnetic fields.
4. Direct sunlight.
5. Dust.
6. Splashes or drops of brine.
7. Temperatures and humidities outside the following ranges:
Temperature range: -10 to 55°C
Humidity range: 25% to 85%

Turn the power OFF before performing installation or wiring.

Correct Use

1. Use crimp terminals suitable for M3.5 screws for wiring.
2. Conformance to EN and UL/CSA Standard
The KM20 Power Sensor conforms to EN61010-1 (IEC61010-1), UL, and CSA standards when used in devices and installations. To meet these standards, however, the KM20 must be used under the following conditions.
 - Basic insulation is provided only for KM20 outputs. To ensure the reinforced insulation (double insulation) required by EN61010-1 (IEC61010-1), provide basic insulation at the load side.
 - Connect either a fuse (1 A max.) that conforms to IEC60127, a UL approved fuse, or a breaker (1 A max.) that conforms to EN60947-2 to the voltage inputs.
 - Use either the KM20-CT050-CE or a current transformer with reinforced insulation.
 - The connecting cables for current transformer input and pulse output must not exceed 30 m in length.
 - Secure the current transformer's output lead wire so that it does not come in contact with exposed SELV. (For details on SELV, refer to IEC364 or NEC class circuits.)
 - Use the KM20 with the terminal cover mounted.

ALL DIMENSIONS SHOWN ARE IN MILLIMETERS.

To convert millimeters into inches, multiply by 0.03937. To convert grams into ounces, multiply by 0.03527.

Cat. No. F054-E1-01 **In the interest of product improvement, specifications are subject to change without notice.**

OMRON Corporation

Industrial Automation Company

Measuring and Control Division
Shiokoji Horikawa, Shimogyo-ku
Kyoto, 600-8530 Japan
Tel: (81)75-344-7108/Fax: (81)75-344-7189

Printed in Japan
1001-1M (1001) (B)