

Phase-sequence Phase-loss Relay

K8AB-PH

Three-phase Phase-sequence Phase-loss Relay Using Voltage Detection Method

- Prevents reverse motor rotation due to incorrect wiring.
- Distinguishes between positive phases, reversed phases, and phase loss when power is turned ON.
- Voltage detection method enables application for any load current.
- One SPDT output relay, 6 A at 250 VAC (resistive load).
- Output status can be monitored using LED indicator.



Model Number Structure

Model Number Legend

K8AB-□□
 1 2 3

1. Basic Model

K8AB: Measuring and Monitoring Relays

2. Functions

PH: Phase-sequence Phase-loss Relay

3. Rated Input Voltage

1: 200 to 500 VAC

Ordering Information

List of Models

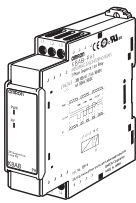
| Phase-sequence Phase-loss Relay | Functions | Rated input voltage (See note.) | Model |
|---|--|---------------------------------|----------|
|  | Phase sequence and phase loss monitoring | 200 to 500 VAC | K8AB-PH1 |

Note: The power supply is shared with the rated input voltage.

Ratings and Specifications

■ Ratings

| | |
|--|--|
| Rated input voltage | Three-phase, three-wire mode, 200 to 500 VAC |
| Input load | 15 VA max. |
| Reversed phase and phase loss operating time | 0.1 s max. |
| Reset method | Automatic reset |
| Indicators | Power (PWR): Green, Relay output (RY): Yellow |
| Output relays | One SPDT relay (NC operation) |
| Output relay ratings | <p>Rated load</p> <p>Resistive load</p> <p>6 A at 250 VAC ($\cos\phi = 1$)</p> <p>6 A at 30 VDC ($L/R = 0$ ms)</p> <p>Inductive load</p> <p>1 A at 250 VAC ($\cos\phi = 0.4$)</p> <p>1 A at 30 VDC ($L/R = 7$ ms)</p> <p>Maximum contact voltage: 250 VAC</p> <p>Maximum contact current: 6 A AC</p> <p>Maximum switching capacity: 1,500 VA</p> <p>Minimum load: 10 mA at 5 VDC</p> <p>Mechanical life: 10,000,000 operations</p> <p>Electrical life: Make: 50,000 times, Break: 30,000 times</p> |
| Ambient operating temperature | -20 to 60°C (with no condensation or icing) |
| Storage temperature | -40 to 70°C (with no condensation or icing) |
| Ambient operating humidity | 25% to 85% (with no condensation) |
| Storage humidity | 25% to 85% (with no condensation) |
| Altitude | 2,000 m max. |
| Terminal screw tightening torque | 0.49 N·m |
| Terminal wiring method | <p>Recommended wire</p> <p>Solid wire: 2.5 mm²</p> <p>Twisted wires: AWG16, AWG18</p> <p>Note: 1. Ferrules with insulating sleeves must be used with twisted wires. 2. Two wires can be twisted together.</p> <p>Recommended ferrules</p> <p>Al 1,5-8BK (for AWG16) manufactured by Phoenix Contact</p> <p>Al 1-8RD (for AWG18) manufactured by Phoenix Contact</p> <p>Al 0,75-8GY (for AWG18) manufactured by Phoenix Contact</p> |
| Case color | Munsell 5Y8/1 |
| Case material | ABS resin (self-extinguishing resin) UL94-V0 |
| Weight | Approx. 110 g |
| Mounting | Mounted to DIN Track or via M4 screws (tightening torque: 1.2 N·m) |
| Dimensions | 22.5 (W) × 90 (H) × 100 (D) mm |

Specifications

| | | |
|--|-----------------------------|---|
| Input voltage range | | 200 to 500 VAC |
| Input frequency range | | 45 to 65 Hz |
| Overload capacity | | Continuous input: 115% of maximum input, 10 s max.: 125% of maximum input |
| Temperature influence | | Operating time Fluctuation based on measured value at standard temperature: -20°C to standard temperature: ±10% max. Standard temperature to 60°C: ±10% max. (Humidity: 25% to 80%) |
| Humidity influence | | Operating time Based on ambient room humidity 25% to 80%: ±10% max. |
| Influence of power supply voltage | | Operating time: ±10% max. Note: The error in the operating value and operating time under standard conditions. |
| Influence of power supply frequency | | Operating time: ±10% max. (at 45 to 65 Hz) Note: The error in the operating value and operating time under standard conditions. |
| Influence of input frequency | | At 45 to 65 Hz Operating time: ±10% max. Note: The error in the operating value and operating time under standard conditions. |
| Applicable standards | Conforming standards | EN60255-5 and EN60255-6 Installation environment (Pollution Degree 2, Overvoltage Category III) |
| | EMC | EN61326 |
| | Safety standards | UL508 |
| Insulation resistance | | 20 MΩ min. Between external terminals and case Between input terminals and output terminals |
| Dielectric strength | | 2,000 VAC for one minute Between external terminals and case Between input terminals and output terminals |
| Noise immunity | | 1,500 V power supply terminal common/normal mode Square-wave noise of ±1 μs/100 ns pulse width with 1-ns rise time |
| Vibration resistance | | Frequency 10 to 55 Hz, 0.35-mm single amplitude, acceleration 50 m/s ² 10 sweeps of 5 min each in X, Y, and Z directions |
| Shock resistance | | 100 m/s ² , 3 times each in 6 directions along three axes (up/down, left/right, forward/backward) |
| Degree of protection | | Terminal section: Finger protection |

Connections

Wiring Diagram

Phase Sequence and Phase Loss Operation Diagram

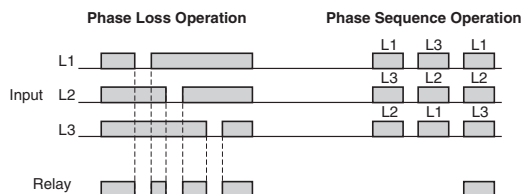

- Note:**
1. Motor load phase loss cannot be detected. To detect motor load phase loss, use the K8AB-PM or K8AB-PA.
 2. The K8AB-PH output relay is normally operative.
 3. L1 and L3 function both as the power supply terminals and as input terminals. If the voltage drops below the minimum input voltage (60%), then the Relay will not operate due to an undervoltage.
 4. Phase loss is detected based on the phase sequence, so phase loss cannot be detected for loads that generate inductive power, e.g., due to monitoring during operation.
 5. Phase loss is detected based on voltage, so phase loss cannot be detected on the load side.

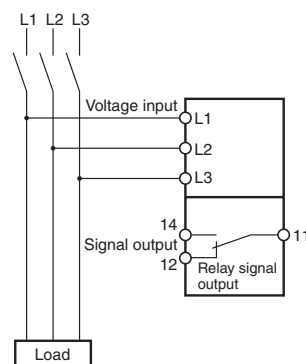

Nomenclature

■ Front

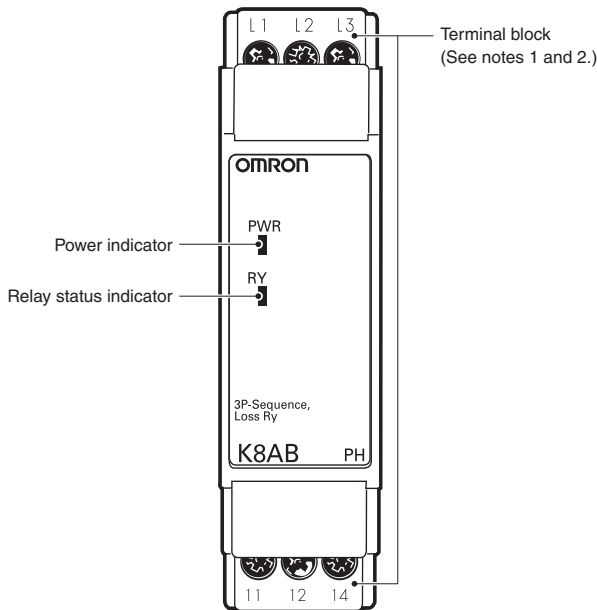

Indicators

| Item | Meaning |
|-------------------------------------|--|
| Power indicator (PWR: Green) | Lit when power is being supplied (see note). |
| Relay status indicator (RY: Yellow) | Lit when relay is operating (normally lit). |

Note: 1. The input across L1 and L3 is used for the internal power supply. Therefore, the power indicator will not be lit if there is no input across L1 and L3.

2. Use either a solid wire of 2.5 mm² maximum or a ferrule with insulating sleeve for the terminal connection. The length of the exposed current-carrying part inserted into the terminal must be 8 mm or less to maintain dielectric strength after connection.

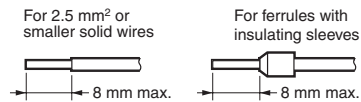

Recommended ferrules
Phoenix Contact

- AI 1,5-8BK (for AWG16)
- AI 1-8RD (for AWG18)
- AI 0,75-8GY (for AWG18)

3. Tightening torque
Recommended: 0.49 N·m
Maximum: 0.54 N·m

■ Operation and Setting Methods

Connections

1. Input

Connect using L1, L2, and L3.

Make sure the phase sequence is wired correctly. The Unit will not operate normally if the phase sequence is incorrect.

2. Outputs

Terminals 11, 12, and 14 are output terminals for SPDT.

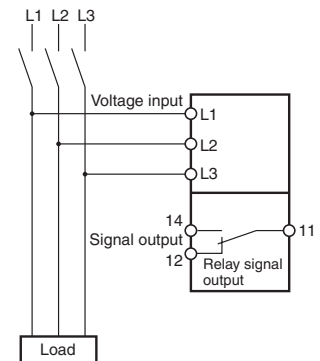

Dimensions

(Unit: mm)

Phase-sequence, Phase-loss Relays

K8AB-PH1

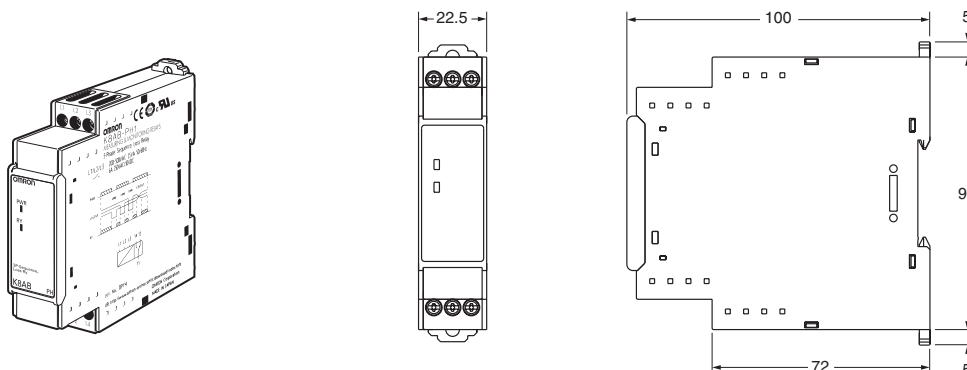

Safety Precautions

■ Precautions for Safe Use

Make sure to follow the instructions below to ensure safety.

1. Do not use or keep this product in the following environments.
 - Outdoors, or places subject to direct sunlight or wearing weather.
 - Places where dust, iron powder, or corrosive gases (in particular, sulfuric or ammonia gas) exist.
 - Places subject to static electricity or inductive noise.
 - Places where water or oil come in contact with the product.
2. Make sure to install this product in the correct direction.
3. There is a remote risk of electric shock. Do not touch terminals while electricity is being supplied.
4. Make sure to thoroughly understand all instructions in the Instructions Manual before handling this product.
5. Make sure to confirm terminal makings and polarity for correct wiring.
6. Tighten terminal screws firmly using the following torque.
Recommended tightening torque: 0.49 N·m
Maximum tightening torque: 0.54 N·m max.
7. Operating ambient temperature and humidity for this product must be within the indicated rating when using this product.
8. There is a remote risk of explosion. Do not use this product where flammable or explosive gas exists.
9. Make sure that no weight rests on the product after installation.
10. To enable an operator to turn off this product easily, install switches or circuit breakers that conform to relevant requirements of IEC60947-1 and IEC60947-3, and label them appropriately.

■ Precautions for Correct Use

For Proper Use

1. Do not use the product in the following locations.
 - Places subject to radiant heat from heat generating devices.
 - Places subject to vibrations or physical shocks.
2. Make sure to use setting values appropriate for the controlled object. Failure to do so can cause unintended operation, and may result in accident or corruption of the product.
3. Do not use thinner or similar solvent for cleaning. Use commercial alcohol.
4. When discarding, properly dispose of the product as industrial waste.
5. Only use this product within a board whose structure allows no possibility for fire to escape.

About Installation

1. When wiring, use only recommended crimp terminals.
2. Do not block areas around the product for proper dissipation of heat. (If you do not secure space for heat dissipation, life cycle of the product will be compromised.)
3. To avoid electrical shocks, make sure that power is not supplied to the product while wiring.
4. To avoid electrical shocks, make sure that power is not supplied to the product when performing DIP switch settings.

Noise Countermeasures

1. Do not install the product near devices generating strong high frequency waves or surges.
2. When using a noise filter, check the voltage and current and install it as close to the product as possible.
3. In order to prevent inductive noise, wire the lines connected to the product separately from power lines carrying high voltages or currents. Do not wire in parallel with or on the same cable as power lines.
Other measures for reducing noise include running lines along separate ducts and using shield lines.

To avoid faulty operations, malfunctions, or failure, observe the following operating instructions.

1. When turning on the power, make sure to realize rated voltage within 1 second from the time of first supply of electricity.
2. Make sure to use power supply for operations, inputs, and transformer with the appropriate capacity and rated burden.
3. Maintenance and handling of this product may only be performed by qualified personnel.
4. Distortion ratio of input wave forms must be 30% or less. Use of this product with circuits that have large distortion in wave forms may result in unwanted operations.
5. Using this product for thyristor controls or inverters will result in errors.
6. When setting the volume, adjust the control from the minimum side to the maximum side.

Questions and Answers

Q Checking Operation

A Phase Sequence
Switch the wiring, as shown by the dotted lines in the connection diagram, to reverse the phase sequence and check that the K8AB operates.

Phase Loss
Create a phase loss for any input phase and check that the K8AB operates.

Connection Diagram

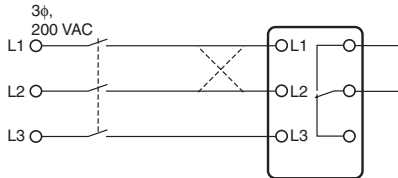

Q Can phase loss be detected on the load side?

A In principle, phase loss cannot be detected on the load side because the K8AB-PH1 measures three-phase voltage to determine phase loss.

Q Motor Load Phase Loss during Operation

A Motor load phase loss cannot be detected during operation. It can be used to detect phase loss at startup.

Normally, three-phase motors will continue to rotate even if one phase is open. The three-phase voltage will be induced at the motor terminals. The diagram shows voltage induction at the motor terminals when phase R has been lost with a load applied to a three-phase motor. The horizontal axis shows the motor load as a percentage of the rated load, and the vertical axis shows voltage as a percentage of the rated voltage. The lines in the graph show the voltage induced at the motor terminals for each load when phase loss occurs during operation. As the graph shows, voltage is induced at the motor terminals even if there is phase loss for a motor load, so the K8AB-PH1 cannot detect phase loss for motor loads during operation. Use the K8AB-PH1 to detect phase loss at startup.

Characteristic Curve Diagram

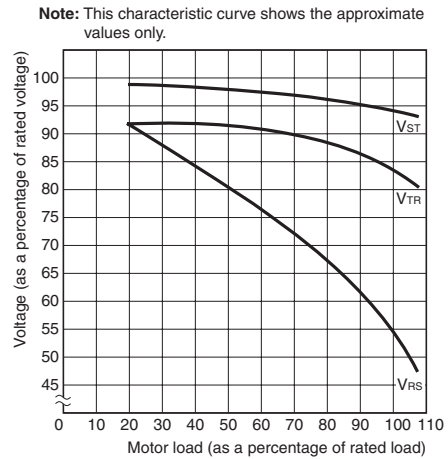

Note: For phase loss of phase R. V_{st}, V_{tr}, and V_{rs} indicate the motor terminal voltage at phase loss.

Warranty and Application Considerations

Read and Understand this Catalog

Please read and understand this catalog before purchasing the products. Please consult your OMRON representative if you have any questions or comments.

Warranty and Limitations of Liability

WARRANTY

OMRON's exclusive warranty is that the products are free from defects in materials and workmanship for a period of one year (or other period if specified) from date of sale by OMRON.

OMRON MAKES NO WARRANTY OR REPRESENTATION, EXPRESS OR IMPLIED, REGARDING NON-INFRINGEMENT, MERCHANTABILITY, OR FITNESS FOR PARTICULAR PURPOSE OF THE PRODUCTS. ANY BUYER OR USER ACKNOWLEDGES THAT THE BUYER OR USER ALONE HAS DETERMINED THAT THE PRODUCTS WILL SUITABLY MEET THE REQUIREMENTS OF THEIR INTENDED USE. OMRON DISCLAIMS ALL OTHER WARRANTIES, EXPRESS OR IMPLIED.

LIMITATIONS OF LIABILITY

OMRON SHALL NOT BE RESPONSIBLE FOR SPECIAL, INDIRECT, OR CONSEQUENTIAL DAMAGES, LOSS OF PROFITS, OR COMMERCIAL LOSS IN ANY WAY CONNECTED WITH THE PRODUCTS, WHETHER SUCH CLAIM IS BASED ON CONTRACT, WARRANTY, NEGLIGENCE, OR STRICT LIABILITY.

In no event shall the responsibility of OMRON for any act exceed the individual price of the product on which liability is asserted.

IN NO EVENT SHALL OMRON BE RESPONSIBLE FOR WARRANTY, REPAIR, OR OTHER CLAIMS REGARDING THE PRODUCTS UNLESS OMRON'S ANALYSIS CONFIRMS THAT THE PRODUCTS WERE PROPERLY HANDLED, STORED, INSTALLED, AND MAINTAINED AND NOT SUBJECT TO CONTAMINATION, ABUSE, MISUSE, OR INAPPROPRIATE MODIFICATION OR REPAIR.

Application Considerations

SUITABILITY FOR USE

OMRON shall not be responsible for conformity with any standards, codes, or regulations that apply to the combination of products in the customer's application or use of the products.

Take all necessary steps to determine the suitability of the product for the systems, machines, and equipment with which it will be used.

Know and observe all prohibitions of use applicable to this product.

NEVER USE THE PRODUCTS FOR AN APPLICATION INVOLVING SERIOUS RISK TO LIFE OR PROPERTY WITHOUT ENSURING THAT THE SYSTEM AS A WHOLE HAS BEEN DESIGNED TO ADDRESS THE RISKS, AND THAT THE OMRON PRODUCTS ARE PROPERLY RATED AND INSTALLED FOR THE INTENDED USE WITHIN THE OVERALL EQUIPMENT OR SYSTEM.

Disclaimers

PERFORMANCE DATA

Performance data given in this catalog is provided as a guide for the user in determining suitability and does not constitute a warranty. It may represent the result of OMRON's test conditions, and the users must correlate it to actual application requirements. Actual performance is subject to the OMRON *Warranty and Limitations of Liability*.

CHANGE IN SPECIFICATIONS

Product specifications and accessories may be changed at any time based on improvements and other reasons. Consult with your OMRON representative at any time to confirm actual specifications of purchased product.

DIMENSIONS AND WEIGHTS

Dimensions and weights are nominal and are not to be used for manufacturing purposes, even when tolerances are shown.

ALL DIMENSIONS SHOWN ARE IN MILLIMETERS.

To convert millimeters into inches, multiply by 0.03937. To convert grams into ounces, multiply by 0.03527.

Cat. No. N145-E1-02 **In the interest of product improvement, specifications are subject to change without notice.**

OMRON Corporation

Industrial Automation Company

Control Devices Division H.Q.

Shiokoji Horikawa, Shimogyo-ku,
Kyoto, 600-8530 Japan

Tel: (81)75-344-7109/Fax: (81)75-344-7149

Printed in Japan

0706-0.7M (0505) (C)