

J7M-AM System

- Rated operational current 25 A.
- Switching capacity up to 10 A, 100 kA/415 V.
- Switching capacity 16 A, 20 A, 25 A, 16 kA/415 V.
- Fixed short-circuit release $14 \times I_U$.
- Overload release, adjustable $0.6-1 \times I_U$.
- Single-phasing sensitivity.

Auxiliary contacts modules

- ON/OFF indication for motor-protective circuit-breaker.
- Differential fault indication of overload/short-circuit tripping.



Current limiter

- Increases the switching capacity of the J7M-AM-16, -20, -25 motor-protective circuit-breakers to 100 kA/440 V.
- Suitable for individual and group protection.

Accessories

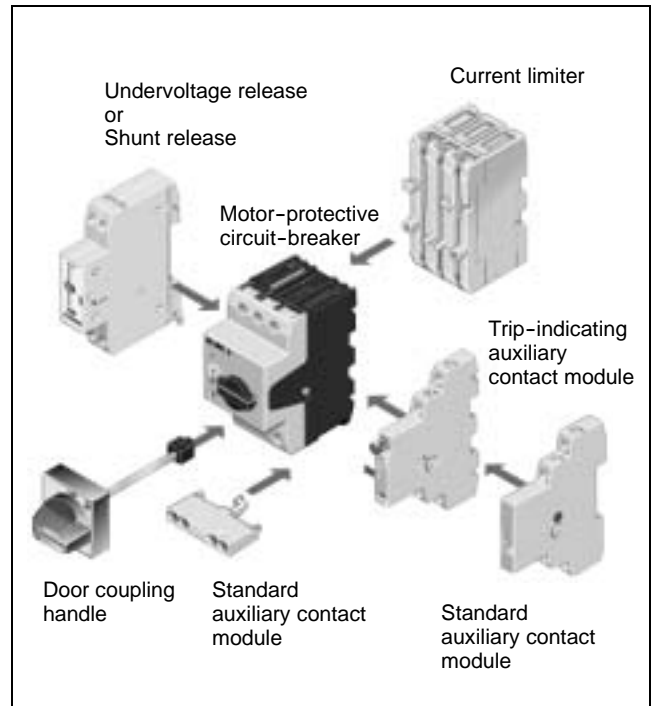
- Undervoltage release.
- Shunt release.
- Three-phase commoning link for series mounting.
- Door coupling handle IP65
Indication of switch position: ON/OFF / Tripped.
Lockable by means of 3 padlocks.
- Lockable rotary handle by means of 1 padlock.
- Surface mounting enclosures with IP55.
- Flush mounting enclosures front IP55.



IEC 947, EN 60947  

J7M-BM System

- Rated operational current 40 A, 18.5 kW/415 V.
- Switching capacity 30 kA/415 V.
- Plug-in trip block.
- Short-circuit release, adjustable.
- Overload release, adjustable.
- Single-phasing sensitivity.
- Finger proof terminals.



Auxiliary contacts modules

- ON/OFF indication for motor-protective circuit-breaker.
- Differential fault indication of overload/short-circuit tripping.

Accessories

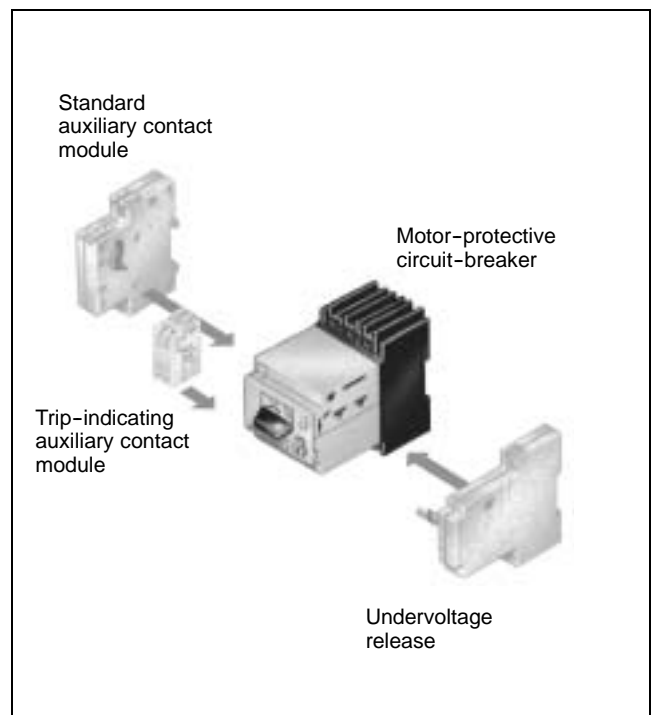
- Undervoltage release.
- Three-phase commoning link for series mounting.
- Lockable handle by means of 1 padlock (hasp thickness 4-6 mm).



IEC 947, EN 60947  

Ordering Information

Model Number Legend:

Motor-protective circuit-breaker:

J7M- j j / j
 1 2 3

1. **Frame size:**
A or B
2. **Load:**
M: motor load
3. **Trip current:**
-x, xx = in case of incorporated trip unit (J7M-AM).
/TB-xx = in case of exchangeable trip block (J7M-BM).

Auxiliary contact modules:

J73M- j j - j j
 1 2 3 4

1. **Frame size:**
A or B
2. **Application:**
M = Motor.
3. **No. of contacts and configuration**
4. **Mounting:**
-E = build in (only J7M-AM).

Accessories:

J7M j -j
 1 2

1. **Frame size of the Motor-protective circuit-breaker:**
A or B
2. **Type of accessories:**
 TI = Trip indicating auxiliary contact module (TI-10, TI-01 for J7MA, TI-11 for J7MB).
 L3- = Link 3 pole devices (1/2, 1/3, 1/4, 1/5 for J7MA, 1/2, 1/3 for J7MB).
 S-L3 = Shroud for L3...
 TC- = Terminal connection 3phases (25/3 for J7MA, 50/3 for J7MB).
 AK = Lockable rotary handle (only for J7MA).
 IE-G(R) = Insulated enclosure for surface mounting (only for J7MA).
 FE-GR = Insulated enclosure for flush mounting (only for J7MA).
 PF-IE = Padlocking facility (only for J7MA-IE-G(R)).
 PF-FE = Padlocking facility (only for J7MA-FE-GR).
 CL = Current limiter.
 RH = Door coupling handle.
 SR = Shunt release.
 U = Undervoltage release.

Available types

J7M-AM system

Type	
Motor-protective circuit-breakers	J7M-AM-0,16
	J7M-AM-0,25
	J7M-AM-0,4
	J7M-AM-0,63
	J7M-AM-1
	J7M-AM-1,6
	J7M-AM-2,5
	J7M-AM-4
	J7M-AM-6,3
	J7M-AM-10
	J7M-AM-16
	J7M-AM-20
	J7M-AM-25
	Standard auxiliary contact modules
J73M-AM-11-E	
Trip-indicating auxiliary contact modules	J7MA-TI-01
	J7MA-TI-10
Current limiter	J7MA-CL
Undervoltage releases	J7MA-U(110V50Hz)
	J7MA-U(230V50Hz)
	J7MA-U(415V50Hz)
Shunt releases	J7MA-SR(415V50Hz)
	J7MA-SR(230V50Hz)
	J7MA-SR(48V50Hz)
	J7MA-SR(24V50Hz)
	J7MA-SR(24VDC)

J7M-BM system



Type	
Motor-protective circuit-breakers	J7M-BM/TB-10
	J7M-BM/TB-16
	J7M-BM/TB-25
	J7M-BM/TB-32
	J7M-BM/TB-40
Standard auxiliary contact module	J73M-BM-11
Trip-indicating auxiliary contact module	J7MB-TI-11
Undervoltage releases	J7MB-U(415V50Hz)
	J7MB-U(230V50Hz)
	J7MB-U(110V50Hz)
	J7MB-U(48V50Hz)
	J7MB-U(24V50Hz)

System overview

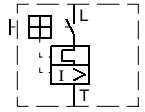
■ Motor-protective circuit-breakers J7M-AM System





J7M-AM

Article No. 	Max. AC-3 rating					Rated uninterrupted current (I_u) (A)	Overload release setting range (I_r) (A) 	Short circuit release (I_{rm}) (A) 	Std. pack
	220 V 230 V 240 V (kW)	380 V 400 V 415 V (kW)	440 V (kW)	500 V (kW)	660 V 690 V (kW)				
J7M-AM-0,16	-	-	-	-	0.06	0.16	0.1 - 0.16	2.2	2 off
J7M-AM-0,25	-	0.06	0.06	0.06	0.12	0.25	0.16 - 0.25	3.5	2 off
J7M-AM-0,4	0.06	0.09	0.12	0.12	0.18	0.4	0.25 - 0.4	5.6	2 off
J7M-AM-0,63	0.09	0.12	0.18	0.25	0.25	0.63	0.4 - 0.63	8.8	2 off
J7M-AM-1	0.12	0.25	0.25	0.37	0.55	1.0	0.63 - 1.0	14.0	2 off
J7M-AM-1,6	0.25	0.55	0.55	0.75	1.1	1.6	1.0 - 1.6	22.0	2 off
J7M-AM-2,5	0.37	0.75	1.1	1.1	1.5	2.5	1.6 - 2.5	35.0	2 off
J7M-AM-4	0.75	1.5	1.5	2.2	3.0	4.0	2.5 - 4.0	56.0	2 off
J7M-AM-6,3	1.1	2.2	3.0	3.0	4.0	6.3	4.0 - 6.3	88.0	2 off
J7M-AM-10	2.2	4.0	4.0	4.0	7.5	10.0	6.3 - 10.0	140.0	2 off
J7M-AM-16	4.0	7.5	9.0	9.0	12.5	16.0	10.0 - 16.0	224.0	2 off
J7M-AM-20	5.5	9.0	11.0	12.5	15.0	20.0	16.0 - 20.0	280.0	2 off
J7M-AM-25	5.5	12.5	12.5	15.0	22	25.0	20.0 - 25.0	350.0	2 off

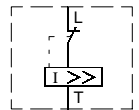
Note: Single-phasing sensitivity to IEC 947-4-1. For snap fitting to EN 50022-35 top-hat rail, height 7.5 or 15 mm.



J7MA-CL Current limiter

Article No. 	Max. AC-3 rating					Rated uninterrupted current (I_u) (A)	Overload release setting range (I_r) (A) 	Short circuit release (I_{rm}) (A) 	Std. pack
	220 V 230 V 240 V (kW)	380 V 400 V 415 V (kW)	440 V (kW)	500 V (kW)	660 V 690 V (kW)				
J7MA-CL	To increase the switching capacity of J7M-AM 0-16, -20, -25 motor-protective circuit-breakers which are not inherently short-circuit-proof, to 100 kA/440 V.					63.0	-	-	2 off

Note: Max. rated operational voltage $U_e = 690$ V. For individual and group protection in combination with J7M-AM 0-16, -20, -25 motor-protective circuit-breakers.
Use input terminals J7MA-TC-25/3 for bigger cable section (≥ 10 mm²).

Standard auxiliary contact modules

For motor-protective circuit-breakers.

Article No.	Contacts M = Make B = Break	Contact sequence	Std. pack
J73M-AM-11 1)	1M 1B		5
J73M-AM-11-E 2)	1M 1B		5

Note: 1. Can be fitted to the right of: Motor-protective circuit-breaker. Can be combined with: J7MA-TI trip-indicating auxiliary contact.
 2. 45 mm width of the motor-protective circuit-breaker remains unchanged.

Trip-indicating auxiliary contact modules

For motor-protective circuit-breakers.

Article No.	Contacts M = Make B = Break	Contact sequence	Std. pack
J7MA-TI-10	2 x 1M	<p>Differential indication a) General trip indication (overload) b) Short circuit trip</p> <p>Local short-circuit indicator by red indicator, can be reset manually.</p>	1
J7MA-TI-01	2 x 1B	<p>Differential indication a) General trip indication (overload) b) Short circuit trip</p> <p>Local short-circuit indicator by red indicator, can be reset manually.</p>	1

Note: Can be fitted to the right of: Motor-protective circuit-breaker. Can be combined with: J73M-AM-11 standard auxiliary contact.

Shunt release

For DC and AC

DC: intermittent operation 5 s.

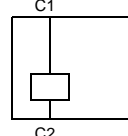
Article No.		Std. pack
J7MA-SR (415 V, 50 Hz) J7MA-SR (230 V, 50 Hz) J7MA-SR (48 V, 50 Hz) J7MA-SR (24 V, 50 Hz) J7MA-SR (24 VDC) 		2

Note: Can be fitted to the left of: Motor-protective circuit-breaker.
Can not be combined with: J7MA-U undervoltage release.

Undervoltage release

For AC

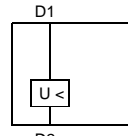

Can be combined with motor-protective circuit-breaker for emergency-stop facility to VDE 0113

Article No.		Std. pack
J7MA-U (415 V, 50 Hz) J7MA-U (230 V, 50 Hz) J7MA-U (110 V, 50 Hz) J7MA-U (48 V, 50 Hz) J7MA-U (24 V, 50 Hz) 		2



Note: Can be fitted to the left of: Motor-protective circuit-breaker.
Cannot be combined with: J7MA-SR shunt release.

■ Accessories

Insulated enclosures for surface mounting for motor-protective circuit-breakers

Article No.	Degree of protection	Note	For use with	Std. pack
J7MA-IE-G 	IP55	With black/grey rotary handle.	J7M-AM-... + J73M-AM-11 + J7MA-TI-... + J73M-AM-11-E or J7M-AM-... + J7MA-U + J73M-AM-11-E or J7M-AM-... + J7MA-SR + J73M-AM-11-E	2
J7MA-IE-GR 	IP55	With red/yellow rotary handle.	J7M-AM-... + J73M-AM-11 + J7MA-TI-... + J73M-AM-11-E or J7M-AM-... + J7MA-U + J73M-AM-11-E or J7M-AM-... + J7MA-SR + J73M-AM-11-E	2
J7MA-PF-IE 	-	Padlocking facility for J7MA-IE-G(R) surface mounting enclosure for up to 3 padlocks with a hasp thickness of 3-6 mm. Can be locked in the OFF position of the J7M-AM.	J7MA-IE-G or J7MA-IE-GR	1

Insulated enclosure for flush mounting for motor-protective circuit-breakers

Article No.	Degree of protection	Note	For use with	Std. pack
J7MA-FE-GR 	Front IP55	With red/yellow rotary handle.	J7M-AM-.. + J73M-AM-11 + J7MA-TI-.. + J73M-AM-11-E or J7M-AM-.. + J7MA-SR + J73M-AM-11-E or J7M-AM-.. + J7MA-U + J73M-AM-11-E	1
J7MA-PF-FE 	-	Padlocking facility for J7MA-FE-GR flush mounting enclosure for up to 3 padlocks with a hasp thickness of 3-6 mm. Can be locked in the OFF position of the J7M-AM.	J7MA-FE-GR	1

Door coupling handle





Article No.	Degree of protection	Note	For use with	Std. pack
J7MA-RH 	IP65	For main switch with emergency-stop function. Colour: red/yellow The plug-fit extension shaft can be cut to any required length for mounting depths from 100-240 mm. Note: The driver pin and extension shaft are supplied with door coupling handle.	J7M-AM-..	1

Lockable rotary handle

Article No.	Note	For use with	Std. pack
J7MA-AK 	For locking the motor-protective circuit-breaker in the OFF POSITION by means of a padlock, hasp thickness 3-6.35 mm.	J7M-AM-..	1

Three-phase commoning links

Protection against accidental contact $U_e = 690\text{ V}$, $I_u = 63\text{ A}$.
Can be extended by mounting in reversed position.

Article No.	Number of MPCB	Lenght	Unit width	Note:	Std. pack
J7MA-L3-1/2 	2	99 mm	45 + 9 mm	For motor-protective circuit-breakers having one auxiliary contact or trip-indicating auxiliary contact fitted on the right.	10
J7MA-L3-1/3 	3	153 mm	45 + 9 mm		10
J7MA-L3-1/4 	4	207 mm	45 + 9 mm		10
J7MA-L3-1/5 	5	261 mm	45 + 9 mm		10

Terminal for three-phase commoning link

Article No.	Note	Std. pack
J7MA-TC25/3 	For three-phase commoning links. Protection against accidental contact, $U_e = 690\text{ V}$, $I_u = 63\text{ A}$. For connecting conductor cross-sections of: 6–25 mm ² stranded 6–16 mm ² flexible with ferrule	5



Shroud for unused terminals

Article No.	Note	For use with	Std. pack
J7MA-S-L3 	Protection against accidental contact. To cover unused terminals on a three-phase commoning link.	J7MA-L3-1/2 J7MA-L3-1/3 J7MA-L3-1/4 J7MA-L3-1/5	20

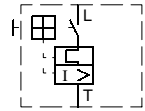
Motor-protective circuit-breakers
J7M-BM System



J7M-BM

Article No. 	Max. AC-3 rating					Rated uninterrupted current (I_u) (A)	Overload release setting range (I_r) (A) 	Short circuit release (I_{rm}) (A) 	Std. pack
	220 V 230 V 240 V (kW)	380 V 400 V 415 V (kW)	440 V (kW)	500 V (kW)	660 V 690 V (kW)				
J7M-BM/TB-10	2.5	4.0	5.0	5.5	7.5	10.0	6.0 - 10.0	80.0 - 140.0	1 off
J7M-BM/TB-16	4.0	7.5	9.0	10.0	13.5	16.0	10.0 - 16.0	130.0 - 220.0	1 off
J7M-BM/TB-25	5.5	12.5	12.5	15.0	22.0	25.0	16.0 - 25.0	200.0 - 350.0	1 off
J7M-BM/TB-32	7.5	15.0	17.5	22.0	22.0	32.0	24.0 - 32.0	275.0 - 425.0	1 off
J7M-BM/TB-40	11.0	20.0	22.0	24.0	27.0	40.0	32.0 - 40.0	350.0 - 500.0	1 off

- Note:**
- Single-phasing sensitivity to IEC 947-4-1.
Can be snap fitted onto a 7.5 or 15 mm top-hat rail to EN 50022-35.
 - Overload release, adjustable $I_r = 0.6-1.0 \times I_u$.
Short-circuit release, adjustable $I_{rm} = 8.5-14 \times I_u$ (factory-set to $12 \times I_u$).

Standard auxiliary contact

For motor-protective circuit-breakers.

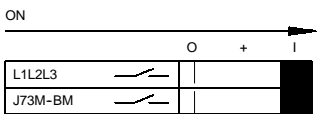
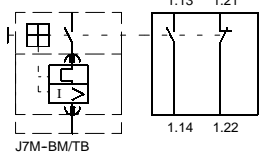
Article No.	Contacts M = Make B = Break	Contact sequence	Std. pack
J73M-BM-11 	1M 1B	 	1 off

- Note:**
- When the motor-protective circuit-breaker is in the tripped position "+", the contacts of the J73M-BM auxiliary contact module are in the OFF position.
 - Can be fitted to motor-protective circuit-breakers. Can be used in conjunction with J7MB-TI-11 trip-indicating contacts.

Trip indicating auxiliary contacts including short-circuit indicator

For motor-protective circuit-breakers.

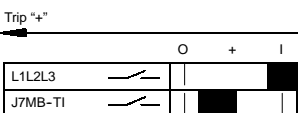
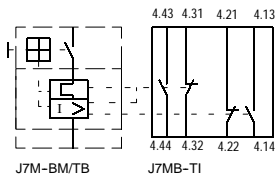
Article No.	Contacts M = Make B = Break	Contact sequence	Std. pack
J7MB-TI-11 	2 x 1M 1B	 <p>Differential remote indication a) General trip indication "+", (overload) b) Short circuit trip</p> 	1 off

- Note:** Can be fitted to motor-protective circuit-breakers. Can be combined with J73M-BM standard auxiliary contacts.

Undervoltage releases

Non delayed

For AC and DC.

In combination with motor-protective circuit-breakers suitable for emergency-stop disconnection to IEC 204.

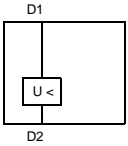

Article No.		Std. pack
J7MB-U (230 V, 50 Hz) J7MB-U (110 V, 50 Hz) J7MB-U (24 VDC) 		1 off

Note: Can be fitted to motor-protective circuit-breakers.

■ Accessories

Three-phase commoning links

Protection against accidental contact for group mounting of two or three circuit breakers 120 A (3 x 40 A).

Article No.	Number of motor-protective circuit-breakers	Length	Note:	Std. pack
J7MB-L3-1/2 	2	140 mm	Space is provided for either one auxiliary contact or one voltage release.	5
J7MB-L3-1/3 	3	222 mm	Space is provided for either two auxiliary contact or two voltage release.	5

Terminal for three-phase commoning link

Terminal is back-of-hand and finger-proof.

For connection of large cable cross-sections or loops.

Article No.	Note	Std. pack
J7MB-TC50/3 	For connecting: 1 x 50 mm ² or 2 x 35 mm ² , one above the other min. 1 x 1 mm ² or 2 x 1 mm ²	1

Shroud for unused terminals

Article No.	Note	For use with	Std. pack
J7MB-S-L3 	Protection against accidental contacts. To cover unused terminals on a three-phase commoning link.	J7MB-L3-1/2 J7MB-L3-1/3	10



■ Modules for motor-starter combinations

Type “1” coordinaton
400/415 V AC

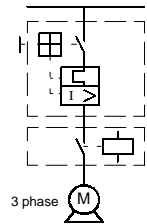

The motor-starter combinations consist of :
Motor-protective circuit-breaker and contactor.
They conform to IEC 947-4-1, EN 60 947-4-1.
 I_q = Rated conditional short-circuit current.



Motor-protective circuit-breaker	Contactor	Motor data		Rated uninterrupted current	Rated short-circuit current 380-400/415 V	Setting range	
		AC-3 380 V 400 V 415 V P (kW)	Rated operational current 400 V I_e (A)			Overload release  I_r (A)	Short-circuit release  I_{rm} (A)
J7M-AM-0,25	J7K-AMA-10(..)	0.06	0.2	0.25	100/100	0.16 - 0.25	3.5
J7M-AM-0,4	J7K-AMA-10(..)	0.09	0.9	0.4	100/100	0.2 - 0.4	5.6
J7M-AM-0,63	J7K-AMA-10(..)	0.12	0.4	0.63	100/100	0.4 - 0.63	8.8
J7M-AM-0,63	J7K-AMA-10(..)	0.18	0.58	0.63	100/100	0.4 - 0.63	8.8
J7M-AM-1	J7K-AMA-10(..)	0.25	0.81	1.0	100/100	0.63 - 1.0	14.0
J7M-AM-1,6	J7K-AMA-10(..)	0.37	1.05	1.6	100/100	1.0 - 1.6	22.0
J7M-AM-1,6	J7K-AMA-10(..)	0.55	1.42	1.6	100/100	1.0 - 1.6	22.0
J7M-AM-2,5	J7K-AMA-10(..)	0.75	1.86	2.5	100/100	1.6 - 2.5	35.0
J7M-AM-4	J7K-AMA-10(..)	1.1	2.65	4.0	100/100	2.5 - 4.0	56.0
J7M-AM-4	J7K-AMA-10(..)	1.5	3.6	4.0	100/100	2.5 - 4.0	56.0
J7M-AM-6,3	J7K-AMA-10(..)	2.2	5.2	6.3	100/100	4.0 - 6.3	88.0
J7M-AM-10	J7K-AMA-10(..)	3.0	6.8	10.0	100/100	6.3 - 10.0	140.0
J7M-AM-10	J7K-AMA-10(..)	4.0	8.8	10.0	100/100	6.3 - 10.0	140.0
J7M-AM-16	J7K-BMA(..)	5.0	11.4	16.0	16/16	10.0 - 16.0	224.0
J7M-AM-16	J7K-CM(..)	7.5	15.4	16.0	16/16	10.0 - 16.0	224.0
J7M-AM-25	J7K-CMA(..)	11.0	22.1	25.0	16/16	16.0 - 25.0	350.0

Type “1” coordinaton
400/415 V AC

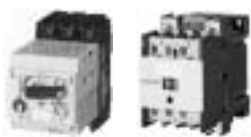



The motor-starter combinations consist of :
Motor-protective circuit-breaker and contactor.
They conform to IEC 947-4-1, EN 60 947-4-1.
 I_q = Rated conditional short-circuit current.

Setting note:

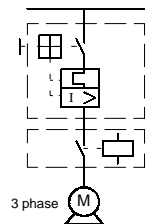
Set the I_{rm} short-circuit release of the J7M-BM/TB motor-protective circuit-breaker to 8.5-14 x rated operational current I_e .



Motor-protective circuit-breaker	Contactor	Motor data		Rated uninterrupted current	Rated short-circuit current 380-415 V	Setting range	
		AC-3 380 V 400 V 415 V P (kW)	Rated operational current 400 V I_e (A)			Overload release  I_r (A)	Short-circuit release  I_{rm} (A)
J7M-BM/TB-10	J7K-CM(..)	3.0	6.8	10.0	100	6.0 - 10.0	80.0 - 140.0
J7M-BM/TB-10	J7K-CM(..)	4.0	8.8	10.0	100	6.0 - 10.0	80.0 - 140.0
J7M-BM/TB-16	J7K-CM(..)	5.5	11.4	16.0	100	10.0 - 16.0	130.0 - 220.0
J7M-BM/TB-16	J7K-CM(..)	7.5	15.4	16.0	100	10.0 - 16.0	130.0 - 220.0
J7M-BM/TB-25	J7K-CMA(..)	11.0	22.1	25.0	30	16.0 - 25.0	200.0 - 350.0
J7M-BM/TB-32	J7K-DM(..)	15.0	28.5	32.0	30	24.0 - 32.0	275.0 - 425.0
J7M-BM/TB-40	J7K-DMA(..)	18.5	35.0	40.0	30	32.0 - 40.0	350.0 - 500.0



Type "1" coordinator
400/415 V AC

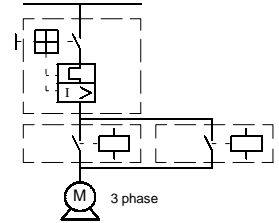

Modules for reversing starter combinations

The reversing-starter combinations consist of :
Motor-protective circuit-breaker and two contactor.
They conform to IEC 947-4-1, EN 60 947-4-1.
 I_q = Rated conditional short-circuit current.



Motor-protective circuit-breaker	Contactor	Motor data		Rated uninterrupted current	Rated short-circuit current 380-415 V	Setting range	
		AC-3 380 V 400 V 415 V P (kW)	Rated operational current 400 V I_e (A)			Overload release  I_r (A)	Short-circuit release  I_{rm} (A)
J7M-AM-0,25	2 x J7K-AMA(..)	0.06	0.2	0.25	100	0.16 - 0.25	3.5
J7M-AM-0,4	2 x J7K-AMA(..)	0.09	0.29	0.4	100	0.25 - 0.4	5.6
J7M-AM-0,63	2 x J7K-AMA(..)	0.12	0.4	0.63	100	0.4 - 0.63	8.8
J7M-AM-0,63	2 x J7K-AMA(..)	0.18	0.58	0.63	100	0.4 - 0.63	8.8
J7M-AM-1	2 x J7K-AMA(..)	0.25	0.81	1.0	100	0.63 - 1.0	14.0
J7M-AM-1,6	2 x J7K-AMA(..)	0.37	1.05	1.6	100	1.0 - 1.6	22.0
J7M-AM-1,6	2 x J7K-AMA(..)	0.55	1.42	1.6	100	1.0 - 1.6	22.0
J7M-AM-2,5	2 x J7K-AMA(..)	0.75	1.86	2.5	100	1.6 - 2.5	35.0
J7M-AM-4	2 x J7K-AMA(..)	1.1	2.65	4.0	100	2.5 - 4.0	56.0
J7M-AM-4	2 x J7K-AMA(..)	1.5	3.6	4.0	100	2.5 - 4.0	56.0
J7M-AM-6,3	2 x J7K-AMA(..)	2.2	5.2	6.3	100	4.0 - 6.3	88.0
J7M-AM-10	2 x J7K-AMA(..)	3.0	6.8	10.0	100	6.3 - 10.0	140.0
J7M-AM-10	2 x J7K-AMA(..)	4.0	8.8	10.0	100	6.3 - 10.0	140.0
J7M-AM-16	2 x J7K-BMA(..)	5.0	11.4	16.0	16	10.0 - 16.0	224.0
J7M-AM-16	2 x J7K-CM(..)	7.5	15.4	16.0	16	10.0 - 16.0	224.0
J7M-AM-25	2 x J7K-CMA(..)	11.0	22.1	25.0	16	20.0 - 25.0	350.0

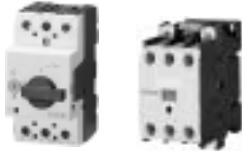

Type "2" coordinaton
400/415 V AC

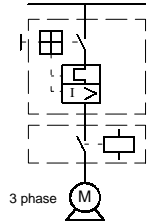

Modules for motor-starter combinations

The motor-starter combinations consist of:
Motor-protective circuit-breaker and contactor.
They conform to IEC 947-4-1, EN 60 947-4-1.
 I_q = Rated conditional short-circuit current.



Motor-protective circuit-breaker	Contactor	Motor data		Rated uninterrupted current I_u (A)	Rated short-circuit current 380-415 V I_q (kA)	Setting range	
		AC-3 380 V 400 V 415 V P (kW)	Rated operational current 400 V I_e (A)			Overload release  I_r (A)	Short circuit release  I_{lm} (A)
J7M-AM-0,25	J7K-AMA(..)	0.06	0.2	0.25	100	0.16 - 0.25	3.5
J7M-AM-0,4	J7K-AMA(..)	0.09	0.29	0.40	100	0.25 - 0.4	5.6
J7M-AM-0,63	J7K-AMA(..)	0.12	0.4	0.63	100	0.4 - 0.63	8.8
J7M-AM-0,63	J7K-AMA(..)	0.18	0.58	0.63	100	0.4 - 0.63	8.8
J7M-AM-1	J7K-AMA(..)	0.25	0.81	1.0	100	0.63 - 1.0	14.0
J7M-AM-1,6	J7K-AMA(..)	0.37	1.05	1.6	100	1.0 - 1.6	22.0
J7M-AM-1,6	J7K-AMA(..)	0.55	1.42	1.6	100	1.0 - 1.6	22.0
J7M-AM-2,5	J7K-CM(..)	0.75	1.86	2.5	100	1.6 - 2.5	35.0
J7M-AM-4	J7K-CM(..)	1.1	2.65	4.0	100	2.5 - 4.0	56.0
J7M-AM-4	J7K-CM(..)	1.5	3.6	4.0	100	2.5 - 4.0	56.0
J7M-AM-6,3	J7K-CM(..)	2.2	5.2	6.3	100	4.0 - 6.3	88.0
J7M-AM-10	J7K-CM(..)	3.0	6.8	10.0	100	6.3 - 10.0	140.0
J7M-AM-10	J7K-CM(..)	4.0	8.8	10.0	100	6.3 - 10.0	140.0
J7M-AM-16	J7K-CM(..)	5.5	11.4	16.0	16	10.0 - 16.0	224.0
J7M-AM-16	J7K-CM(..)	7.5	15.4	16.0	16	10.0 - 16.0	224.0
J7M-AM-25	J7K-CMA(..)	11.0	22.1	25.0	16	20.0 - 25.0	350.0

Type "2" coordinator
400/415 V AC



Modules for reversing starter combinations

The reversing starter combinations consist of :
Motor-protective circuit-breaker and two contactors.
They conform to IEC 947-4-1, EN 60 947-4-1.
 I_q = Rated conditional short-circuit current.

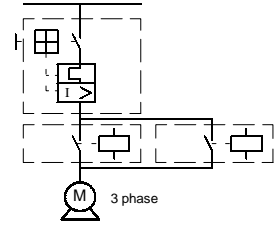

Motor-protective circuit-breaker	Contactor	Motor data		Rated uninterrupted current I_u (A)	Rated short-circuit current 380-415 V I_q (kA)	Setting range	
		AC-3 380 V 400 V 415 V P (kW)	Rated operational current 400 V I_e (A)			Overload release I_r (A)	Short-circuit release I_{rm} (A)
J7M-AM-0,25	2 x J7K-AMA(..)	0.06	0.2	0.25	100	0.16 - 0.25	3.5
J7M-AM-0,4	2 x J7K-AMA(..)	0.09	0.29	0.40	100	0.25 - 0.4	5.6
J7M-AM-0,63	2 x J7K-AMA(..)	0.12	0.4	0.63	100	0.4 - 0.63	8.8
J7M-AM-0,63	2 x J7K-AMA(..)	0.18	0.58	0.63	100	0.4 - 0.63	8.8
J7M-AM-1	2 x J7K-AMA(..)	0.25	0.81	1.0	100	0.63 - 1.0	14.0
J7M-AM-1,6	2 x J7K-AMA(..)	0.37	1.05	1.6	100	1.0 - 1.6	22.0
J7M-AM-1,6	2 x J7K-AMA(..)	0.55	1.42	1.6	100	1.0 - 1.6	22.0
J7M-AM-2,5	2 x J7K-CM(..)	0.75	1.86	2.5	100	1.6 - 2.5	35.0
J7M-AM-4	2 x J7K-CM(..)	1.1	2.65	4.0	100	2.5 - 4.0	56.0
J7M-AM-4	2 x J7K-CM(..)	1.5	3.6	4.0	100	2.5 - 4.0	56.0
J7M-AM-6,3	2 x J7K-CM(..)	2.2	5.2	6.3	100	4.0 - 6.3	88.0
J7M-AM-10	2 x J7K-CM(..)	3.0	6.8	10.0	100	6.3 - 10.0	140.0
J7M-AM-10	2 x J7K-CM(..)	4.0	8.8	10.0	100	6.3 - 10.0	140.0
J7M-AM-16	2 x J7K-CM(..)	5.5	11.4	16.0	16	10.0 - 16.0	224.0
J7M-AM-16	2 x J7K-CM(..)	7.5	15.4	16.0	16	10.0 - 16.0	224.0
J7M-AM-25	2 x J7K-CMA(..)	11.0	22.1	25.0	16	20.0 - 25.0	350.0

Specifications

General

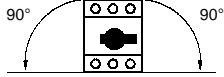
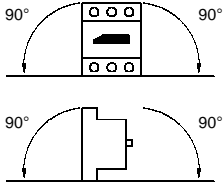
Typ		J7M-AM	J7M-BM
Standards		IEC 947, EN 60947, DIN VDE 0660, UL 508, CSA C 22.2 No. 14, GL, LRs, DNV, PRS, BV, RINA, RS	
Climatic proofing		Damp heat, constant, to IEC 68 Part 2-3 Damp heat, cyclic, to IEC 68 Part 2-30	
Ambient temperature	Storage	min. -25 °C/ max. +70 °C	min. -25 °C/ max. +70 °C
	Open	min. -25 °C/ max. +55 °C	min. -25 °C/ max. +60 °C
Mounting position			
Direction of incoming supply		As required	
Degree of protection to IEC 947 (terminals)		IP20 (IP00)	IP20
Protection against electric shock		Finger- and back-of-hand proof	
Mechanical shock resistance	Half-sinusoidal shock 10 ms	25 g	-
	Half-sinusoidal shock 20 ms	-	30 g
Altitude		2000 m	
Terminal capacities	1 conductor (solid); min./max.	1 - 6 mm ²	-
	1 conductor (solid), stranded; min./max.	-	1.0/16
	1 conductor (flexible with ferrule); min./max.	1 - 4 mm ²	1.5/10
	2 conductor (solid); min./max.	1 - 2.5 mm ²	-
	2 conductor (solid), stranded; min./max.	-	1.0/6
	2 conductor (flexible with ferrule); min./max.	1 - 2.5 mm ² 18 - 10 AWG	1.5/6 14/6 AWG
Specified tightening torque for terminal screws	Main cable	1.7 Nm	1.8 Nm
	Control circuit cable	1.0 Nm	1.0 Nm

Main contacts

Typ		J7M-AM	J7M-BM
Rated impulse withstand voltage U_{imp}		6000 V	
Overvoltage category / pollution degree		III/3	
Rated operational voltage U_e		690 V AC	
Rated uninterrupted current I_u = rated operational current I_e		25 A or setting current of overload release	40 A
Rated frequency		40 - 60 Hz	50 - 60 Hz
Number of poles		3	3
Current heat losses (3-pole at operational temperature)		6 W	14 W
Lifespan	mechanical	0.1 x 10 ⁶ Operations	0.1 x 10 ⁶ Operations
	electrical (100 %; AC-3/400 V)	0.1 x 10 ⁶ Operations	0.05 x 10 ⁶ Operations
Max. operating frequency		40 Ops./hour	60 Ops./hour
Motor switching capacity	AC-3	max. 690 V AC	max. 690 V AC
	DC-5	max. 250 V DC	max. 250 V DC
Rated short-circuit breaking capacity I_{cn}	250 V DC; L/R = 15 ms	-	30 kA
	125 V DC; L/R = 15 ms	-	50 kA
Operating times under short-circuit conditions	Minimum command time	-	Approx. 2 ms
	Opening delay	-	Approx. 0.5 ms
	Total opening time	-	Approx. 6 ms

Trip blocks

Typ		J7M-AM	J7M-BM
Temperature compensation	IEC 947, EN 60947, DIN VDE 0660	min. - 5 °C/ max. + 40 °C	min. - 5 °C/ max. + 40 °C
	Operating range	min. - 25 °C/ max. + 55 °C	
Temperature compensation residual error to IEC 947, EN 60947, DIN VDE 0660		≤ 0.25 - 0.4 %/K	0.25 %/K
Adjustable overload releases		0.6 - 1 x I _U	
Fixed short-circuit releases		14 x I _U	-
Adjustable short-circuit releases		-	8.5 - 14 x I _U
Short-circuit release tolerance		± 20 %	
Single-phasing sensitivity		IEC 947-4-1, EN 60947-4-1, DIN VDE 0660 Part 102	

Current limiter

Typ	J7MA-CL	-
Rated impulse withstand voltage U _{imp}	6000 V	-
Overvoltage category / pollution degree	III/3	-
Rated operational voltage U _e	440 V AC	-
Rated uninterrupted current I _U	63 A	-

Terminal for three-phase commoning link

Typ	J7MA-TC25/3	J7MB-TC50/3
Rated impulse withstand voltage U _{imp}	6000 V	6000 V
Overvoltage category/pollution degree	III/3	III/3
Rated operational voltage U _e	690 V AC	690 V AC
Rated uninterrupted current I _U	63 A	120 A

Three-phase commoning links

Typ	J7MA-L3-...	J7MB-L3-...
Rated impulse withstand voltage I _{imp}	6000 V	6000 V
Overvoltage category/pollution degree	III/3	III/3
Rated operational voltage U _e	690 V AC	690 V AC
Rated uninterrupted current I _U	63 A (J7MA-L3-./.)	120 A (3 x 40 A) (J7MB-L3-1/3) 120 A (J7MB-L3-1/2)

Auxiliary contact modules

Typ		J7M-AM	J7M-BM	
Rated impulse withstand voltage U_{imp}		6000 V (4000 for J73M-AM-11-E)	6000 V	
Overvoltage category/pollution degree		III/3	III/3	
Rated operational voltage U_e		500 V AC, 250 V DC	500 V AC	
Safe isolation to DIN VDE 0106 Part 101 and Part 101 A1 between auxiliary contacts and main contacts		690 VAC	-	
Rated operational current I_e	AC-15	220-240 V	3.5 A (1 A for J73M-AM-11-E)	
		380-415 V	2 A	
		440-500 V	1 A	
	AC-15 (J73M-BM-11)	230-240 V	-	6 A
		400-415 V	-	3 A
		440-500 V	-	1.5 A
	AC-15 (J7MB-TI-11)	230-240 V	-	5 A
		400-415 V	-	3 A
		440-500 V	-	1.5 A
	DC-13 (L/R ≤ 100 ms)	24 V	2 A	-
		60 V	1.5 A (1 A for J73M-AM-11-E)	-
		110 V	1 A (0.5 A for J73M-AM-11-E)	-
		220 V	0.25 A	-
Component lifespan	mechanical	J73M-j M-11	0.1 x 10 ⁶ Ops.	
		J73M-AM-11-E	0.1 x 10 ⁶ Ops.	
		J7Mj -TI-..	0.01 x 10 ⁶ Ops.	
	electrical	J73M-j M-11	0.01 x 10 ⁶ Ops.	
		J73M-AM-11-E	0.1 x 10 ⁶ Ops.	
		J7Mj -TI	5 x 10 ³ Ops.	
Control circuit reliability Fault probability H_F at rated operational voltage 24 V DC	$U_{min} = 17 V$, $I_{min} = 5.4 mA$	< 10 ⁻⁸ , < fault in 1 x 10 ⁸ operations	-	
	$U_{min} = 24 V$, $I_{min} = 10 mA$	-	Fail-safe over the entire mechanical lifespan	
Interlocked opposing contacts to ZH 1/457		J73M-AM-11	J7MB-TI-11	
Short-circuit rating without welding	Fuseless	Please enquire	240 V (J7M-AM-6,3)	
		-	415 V (J7M-AM-4)	
		-	500 V (J7M-AM-1,6)	
	Fuse	10 A gL	10 A gL	
Terminal capacities	1 conductor or 2 conductors solid or flexible with ferrule	min. 0.75 mm ² - max. 2.5 mm ² (min. 0.75 mm ² - max. 1.5 mm ² for J73M-AM-11-E) min. 18 AWG - max. 14 AWG (min. 18 AWG - max. 16 AWG for J73M-AM-11-E)	min. 0.75 mm ² - max. 2.5 mm ² min. 22 AWG - max. 14 AWG	

Voltage release

Typ		J7MA-U	J7MB-U
Rated impulse withstand voltage U_{imp}		6000 V	
Overvoltage category/pollution degree		III/3	
Rated operational voltage U_e		42 - 480 V AC 24 - 250 V DC	24 - 600 V AC 24 - 125 V DC
Terminal capacities	1 conductor or 2 conductors solid or flexible with ferrule	min. 0.75 mm ² - max. 2.5 mm ² min. 18 AWG - max. 14 AWG	min. 0.75 mm ² - max. 2.5 mm ² min. 22 AWG - max. 14 AWG

Shunt release

Typ		J7MA-SR	-
Operating range	AC	0.7-1.1 x U _S	-
	DC (intermittent operator: 5 s)	0.7-1.1 x U _S	-
Power consumption	Pull-in AC	5 VA	-
	Holding AC	3 VA	-
	Pull-in DC	3 W	-
	Holding DC	3 W	-

Undervoltage release

Typ		J7MA-U	J7MB-U
Pick-up voltage		0.85 x U _S	-
Drop-out voltage		0.7 - 0.35 x U _S	0.7 - 0.35 x U _S
Power consumption	Pull-in AC	5 VA	5 VA
	Holding AC	3 VA	3 VA
	Pull-in DC	-	3 W
	Holding DC	-	3 W

Switching capacity to IEC 947-4-1, coordination types “1” and “2” and to IEC 947-2

Motor-protective circuit-breaker J7M-AM

Rated uninterrupted current I_u

Rated conditional short-circuit current I_q (IEC 947-4-1)

Rated ultimate short-circuit breaking capacity I_{cu} (IEC 947-2)

Rated service short-circuit breaking capacity I_{cs} (IEC 947-2)

I _u A	230 V				400 V				440 V				500 V				690 V			
	I _q (kA)	I _{cu} (kA)	I _{cs} (kA)	⌈ (A ²)	I _q (kA)	I _{cu} (kA)	I _{cs} (kA)	⌈ (A ²)	I _q (kA)	I _{cu} (kA)	I _{cs} (kA)	⌈ (A ²)	I _q (kA)	I _{cu} (kA)	I _{cs} (kA)	⌈ (A ²)	I _q (kA)	I _{cu} (kA)	I _{cs} (kA)	⌈ (A ²)
0.16-1.0	1)																			
1.6	1)																			
2.5	1)																			
4.0	1)																			
6.3	1)																			
10.0	1)																			
16.0	16	16	8	50	16	16	8	50	10	10	10	50	6	6	6	50	3	3	2	50
20.0	16	16	8	50	16	16	8	50	10	10	10	50	6	6	6	50	3	3	2	50
25.0	16	16	8	50	16	16	8	50	10	10	10	50	6	6	6	50	3	3	2	50

J7M-AM + J7MA-CL

0.16-1.0	1)	N ³⁾	1)	N ³⁾	1)	N ³⁾	1)	N ³⁾	1)	N ³⁾	1)	N ³⁾	1)	A ⁴⁾	N ³⁾	
1.6		N ³⁾		N ³⁾		N ³⁾		N ³⁾		N ³⁾		N ³⁾		A ⁴⁾	N ³⁾	
2.5		N ³⁾		N ³⁾		N ³⁾		N ³⁾		N ³⁾		N ³⁾	20	20	A ⁴⁾	N ³⁾
4.0		N ³⁾		N ³⁾		N ³⁾		N ³⁾		N ³⁾		N ³⁾	20	20	A ⁴⁾	N ³⁾
6.3		N ³⁾		N ³⁾		N ³⁾		N ³⁾	50	50	50	N ³⁾	20	20	A ⁴⁾	N ³⁾
10.0		N ³⁾		N ³⁾		N ³⁾		N ³⁾	20	20	20	N ³⁾	20	20	A ⁴⁾	N ³⁾
16.0		N ³⁾		N ³⁾		N ³⁾		N ³⁾	20	20	20	N ³⁾	5	5	A ⁴⁾	N ³⁾
20.0		N ³⁾		N ³⁾		N ³⁾		N ³⁾	10	10	10	N ³⁾	5	5	A ⁴⁾	N ³⁾
25.0		N ³⁾		N ³⁾		N ³⁾		N ³⁾	10	10	10	N ³⁾	5	5	A ⁴⁾	N ³⁾

- Note:**
1. No upstream protective device required, inherently short-circuit-proof range (100 kA)
 2. Back-up fuse required when the fault current exceeds the rated short-circuit breaking capacity of the motor-protective circuit-breaker I_{cc} > I_{cn}
The rated conditional short-circuit current I_q depending on the fuse used:
50 A gL: I_q = 100 kA
100 A gL: I_q = 30 kA
 3. N = Not necessary
 4. A = Please, ask for more information

**Switching capacity to IEC 947-4-1, coordination types “1” and “2” and to IEC 947-2
Motor-protective circuit-breaker J7M-BM**

Rated uninterrupted current I_u

Rated conditional short-circuit current I_q (IEC 947-4-1)

Rated ultimate short-circuit breaking capacity I_{cu} (IEC 947-2)

Rated service short-circuit breaking capacity I_{cs} (IEC 947-2)

I_u A	230 V				400 V				440 V				500 V				690 V			
	I_q (kA)	I_{cu} (kA)	I_{cs} (kA)	$\int I^2 dt$ A ²	I_q (kA)	I_{cu} (kA)	I_{cs} (kA)	$\int I^2 dt$ A ²	I_q (kA)	I_{cu} (kA)	I_{cs} (kA)	$\int I^2 dt$ A ²	I_q (kA)	I_{cu} (kA)	I_{cs} (kA)	$\int I^2 dt$ A ²	I_q (kA)	I_{cu} (kA)	I_{cs} (kA)	$\int I^2 dt$ A ²
10.0	1)		30	1)		30	1)		10	10	5	80	7	7	3.5	80	4.5	4.5	2.5	80
16.0			30			30			10	10	5	100	7	7	3.5	100	4.5	4.5	2.5	100
25.0	30	30	7.5	160	30	30	7.5	160	10	10	5	125	7	7	3.5	125	4.5	4.5	2.5	125
32.0	30	30	7.5	160	30	30	7.5	160	10	10	5	160	7	7	3.5	160	4.5	4.5	2.5	160
40.0	30	30	7.5	160	30	30	7.5	160	10	10	5	160	7	7	3.5	160	4.5	4.5	2.5	160

- Note:**
1. No upstream protective device required, inherently short-circuit-proof range (100 kA)
 2. Back-up fuse required when the fault current exceeds the rated short-circuit breaking capacity of the motor-protective circuit-breaker $I_{cc} > I_{cn}$

1- and 2-pole circuits for J7M-AM and J7M-BM devices used for DC and AC switching

1-pole

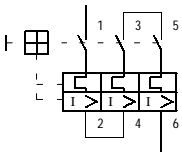

2-pole

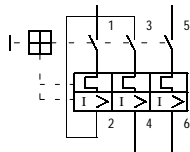

Protection of PVC-insulated cables against thermal overload in fault conditions

The tables shows which minimum cable cross-sections are protected by J7M devices up to their rated short-circuit current I_q .

Device type	Min. cross-section protected 380-415 V, 50 Hz, Cu mm ²				
Device type	4.0	2.5	1.5	1.0	0.75
J7M-AM-0.16	X	X	X	X	X
...					
J7M-AM-6.3	X	X	X	X	X
J7M-AM-10	X	X	X	X	
J7M-AM-16	X	X	X		
J7M-AM-20	X	X	X		
J7M-AM-25	X	X			
J7M-BM-10	X	X	X		
J7M-BM-16	X	X			
J7M-BM-25	X				
J7M-BM-32	X				
J7M-BM-40	X				

Engineering Data

J7M-AM

Tripping characteristics
motor-protective circuit-breakers

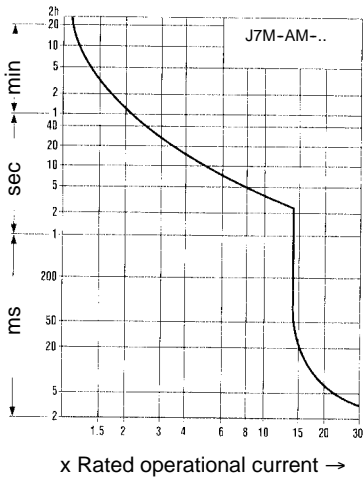

J7M-BM

Tripping characteristics
motor-protective circuit-breakers

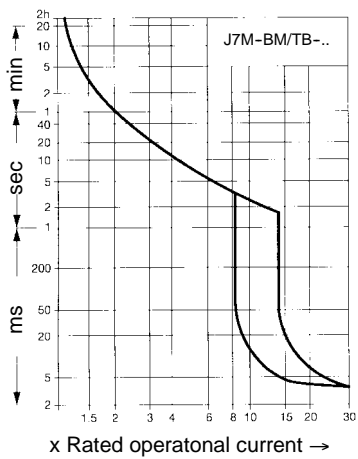

Dimensions

J7M-AM system

Motor-protective circuit-breaker
J7M-AM-... + J73M-AM-11-E

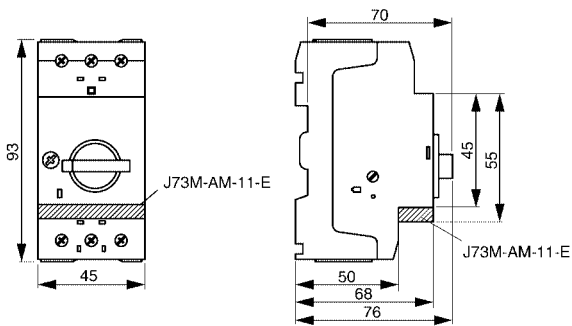

Motor-protective circuit-breaker
with lockable rotary handle
J7M-AM-... + J7MA-AK

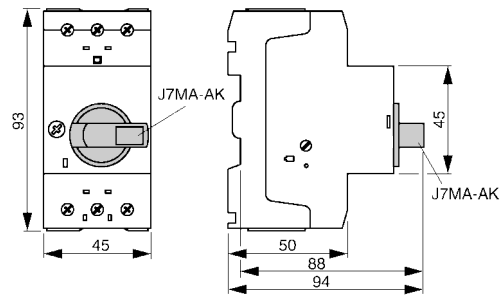

Voltage releases
J7MA-U
J7MA-SR

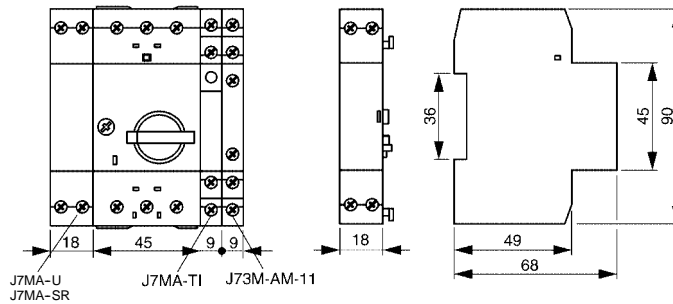

Current limiter
J7MA-CL

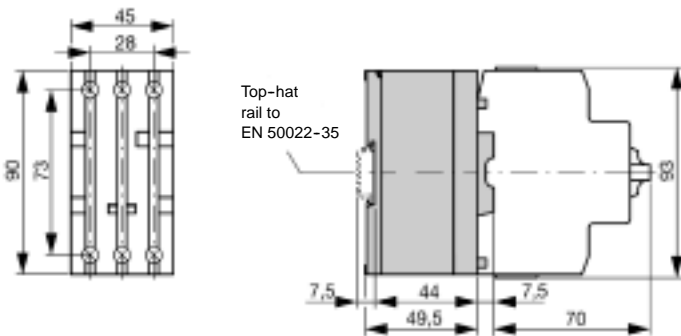

Standard auxiliary contact module
J73M-AM-11

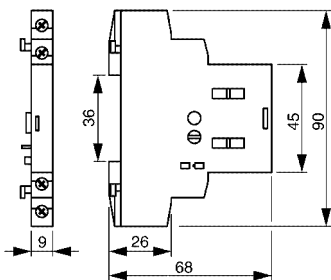

Trip-indicating auxiliary contact module
J7MA-TI-...

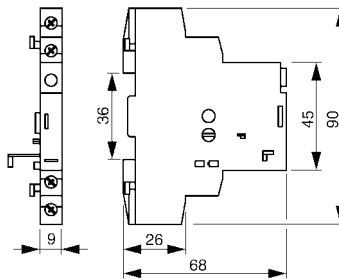

**Three-phase commoning link
J7MA-L3-(1/5, 1/4, 1/3, 1/2)**

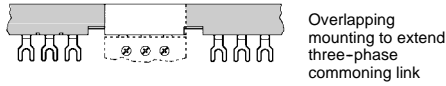
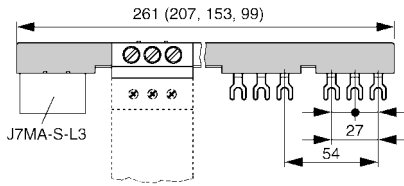

**Terminal
J7MA-TC25/3**

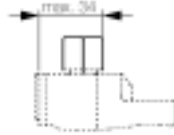
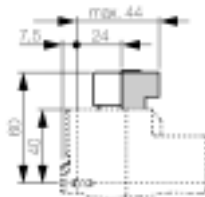

**Shroud for unused terminals
J7MA-S-L3**

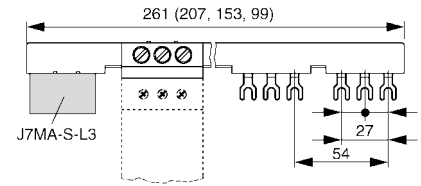

**J7MA-IE-G(R) Insulated enclosures for surface mounting
J7MA-PF-IE Padlocking facility**

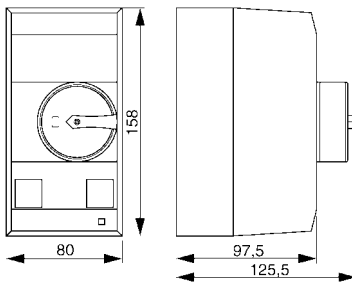

**Door coupling handle
J7MA-RH**

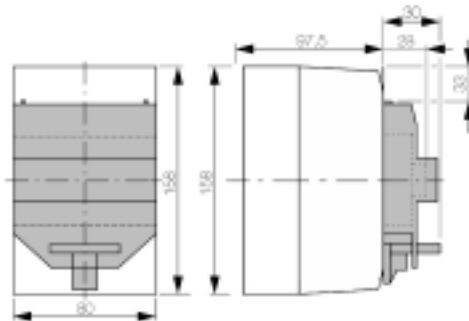
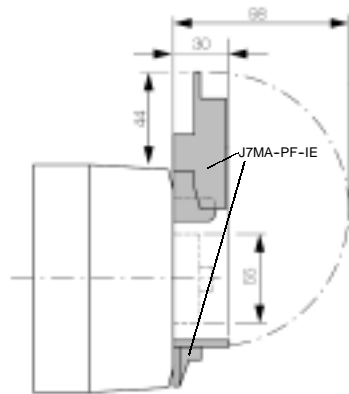
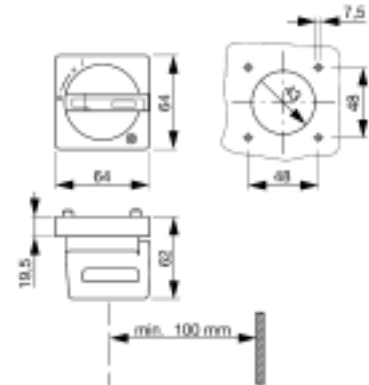

Drilling dimensions



**J7MA-FE-GR Insulated enclosures for flush mounting
J7MA-PF-FE Padlocking facility**

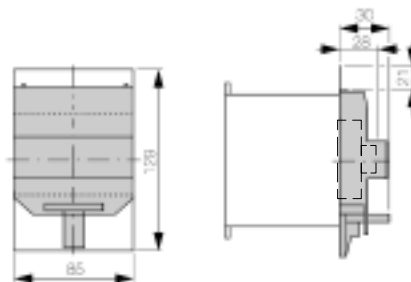
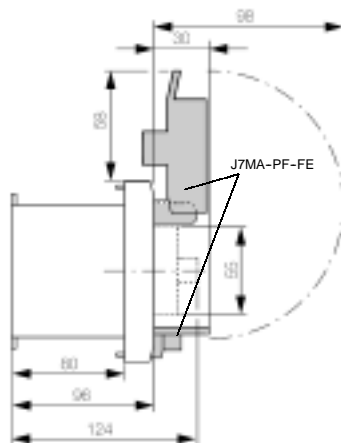

Mounting aperture

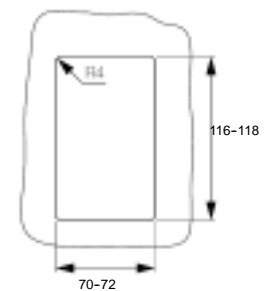

Aperture for 2-6 mm panel thickness

J7M-BM system

**Motor-protective circuit-breakers
J7M-BM/TB**

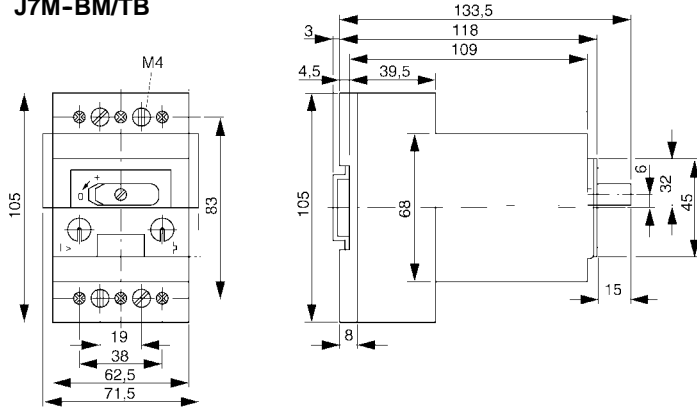

**Trip-indicating contact module
J7MB-TI-11**

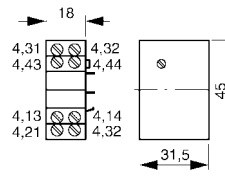

**Standard auxiliary contact module
J73M-BM-11**

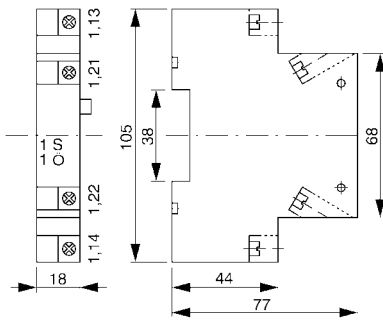

**Undervoltage release
J7MB-U**

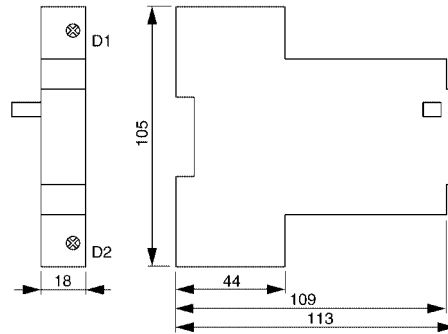

**Three-phase commoning link
J7MB-L3-1/3**

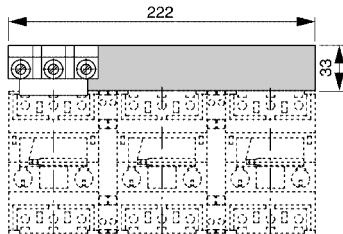

J7MB-L3-1/2

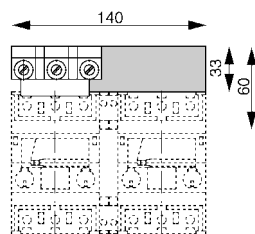

**Terminal
J7MB-TC50/3**

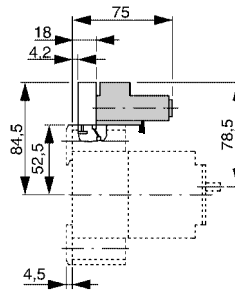

**Shroud for unused terminals
J7MB-S-L3**

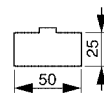

ALL DIMENSIONS SHOWN ARE IN MILLIMETERS.
To convert millimeters into inches or grams into ounces, please see page 107.