

Sub-Miniature Automotive PCB Relay

- Compact size.
- High performance PCB relay.
- Fully sealed construction.
- Next generation general purpose automotive PCB relay.
- Fully automated assembly.

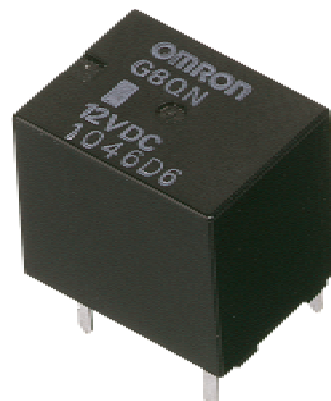

Available Types

Type	Contact form	Recommended loads
G8QN-1C4 12DC	SPDT	Motor, Resistive

Contact Data

Continuous carry current (max.)	5A
Inrush current (L/R=7ms; 15ms max.)	20A
Contact voltage drop (Initial value at 23°C) (max.)	100mΩ

Ratings/Specifications

Rated voltage	12 VDC	
Operating voltage (max.)	16 VDC	
Coil resistance	210 Ω ± 10%	
Pull in voltage (cold start)	at +20°C (max.)	7.3V DC
	at +80°C (max.)	9.0V DC
Drop-out voltage at +20°C (min.)	0.9V DC	
Continuous carry current flow time (16V at 80°C) (max.)	15min.	
Operate time (max.)	10 ms	
Release time (max.)	5 ms	
Operating ambient temperature	-40°C to +85°C	
Mechanical life (min.)	10,000,000 cycles (at frequency of 18,000 operations/hour)	
Electrical life (resistive load) (min.)	100,000 cycles (14V; Continuous carry current)	
Weight	5.5g	

Application Examples

- Power window
- Electric sunroof
- Intermittent Windshield wiper
- Power door lock
- Power seat
- Electric wing mirror
- Power radio aerial
- Washer pump

Dimensions

(All dimensions in mm)

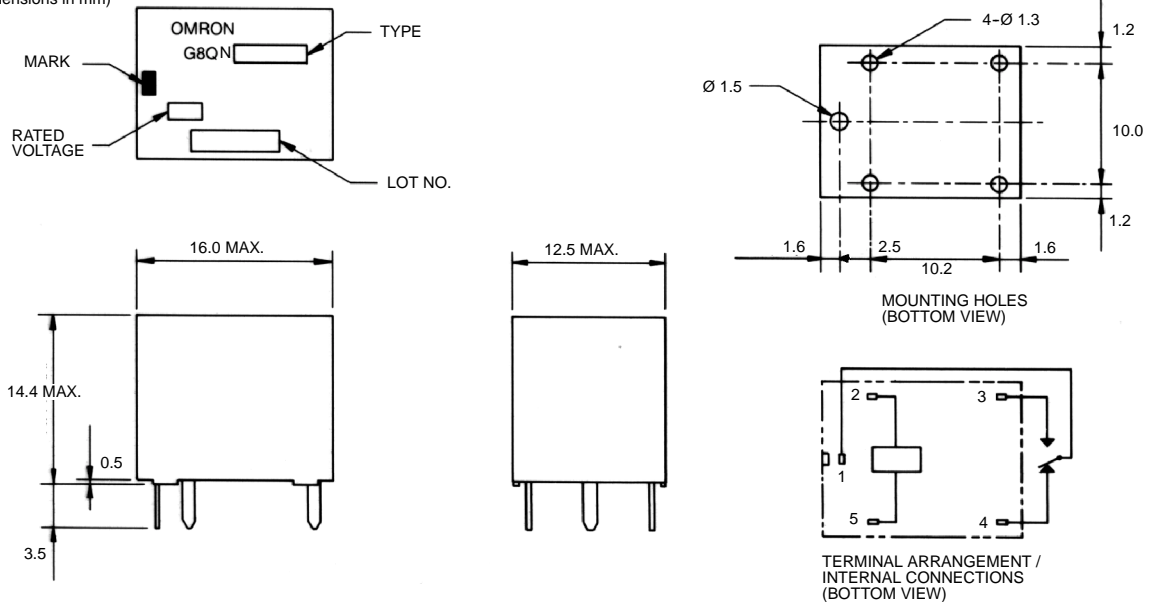

- Omron PCB relays may be mounted in any convenient location that is dry and not exposed to excessive dust, SO_2 , H_2S or organic gases.
- All Omron PCB relays may be oriented in any desired direction. Whenever possible, however, care should be taken that they are not subjected to vibration along the direction of contact movement.
- If several relays are to be mounted on a single printed circuit board, they should be given at least 3mm clearance on all sides as shown in the diagram below.

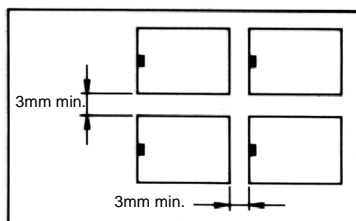

Note: Proper spacing is necessary to dissipate heat build-up from individual relays. Other than this, there are normally no restrictions depending on application. Please contact Omron for details.

Cat. No. K903-E2-01 In the interest of product improvement, specifications are subject to change without notice.

OMRON

LEADERS IN ELECTRONIC COMPONENTS

OMRON Electronics Ltd.

1, Apsley Way,
Staples Corner,
London NW2 7HF
Phone: 020 8450 4646 Fax: 020 8450 8087