

Subminiature, Sensitive SPDT Signal Switching Relay

- High sensitivity: 98-mW pickup coil power.
- Impulse withstand voltage meets FCC Part 68 requirements.
- Fully sealed construction.
- Unique moving loop armature reduces relay size, magnetic interference, and contact bounce time.
- Single- and double-winding latching types also available.



RC

Ordering Information

Contact form		Terminal	Single-side stable	Single-winding latching	Double-winding latching
SPDT	Bifurcated crossbar	Straight terminal	G6E-134P-US	G6EU-134P-US	G6EK-134P-US
		Self-clinching terminal	G6E-134C-US	G6EU-134C-US	G6EK-134C-US

Note: When ordering, add the rated coil voltage to the model number.

Example: G6E-134P-US 12 VDC

Rated coil voltage

Model Number Legend

G6E - - VDC
 1 2 3 4 5 6 7 8 9

1. Relay Function

None: Single-side stable
 U: Single-winding latching
 K: Double-winding latching

2. Contact Form

1: SPDT

3. Contact Type

3: Bifurcated crossbar
 Ag (Au-clad) contact
 9: Bifurcated crossbar
 AgNi (Au-clad) contact

4. Enclosure Ratings

4: Fully sealed

5. Terminals

P: Straight PCB
 C: Curved tail

6. Special Function

L: Low sensitivity coil (400 mW)

7. Approved Standards

US: UL, CSA certified

8. Special Function

U: For ultrasonically cleanable

9. Rated Coil Voltage

3, 5, 6, 9, 12, 24, 48 VDC

Specifications

■ Coil Ratings

Single-side Stable, Bifurcated Crossbar Contact Type

Rated voltage	3 VDC	5 VDC	6 VDC	9 VDC	12 VDC	24 VDC	48 VDC
Rated current	66.7 mA	40 mA	33.3 mA	22.2 mA	16.7 mA	8.3 mA	8.3 mA
Coil resistance	45 Ω	125 Ω	180 Ω	405 Ω	720 Ω	2,880 Ω	5,760 Ω
Coil inductance (H) (ref. value)	Armature OFF	0.08	0.18	0.31	0.62	1.20	5.35
	Armature ON	0.06	0.17	0.24	0.50	0.99	5.12
Must operate voltage	70% max. of rated voltage						
Must release voltage	10% min. of rated voltage						
Max. voltage	155% of rated voltage at 50°C, 130% at 70°C						140% of rated voltage at 50°C, 115% at 70°C
Power consumption	Approx. 200 mW						Approx. 400 mW

Single-winding Latching, Bifurcated Crossbar Contact Type

Rated voltage	3 VDC	5 VDC	6 VDC	9 VDC	12 VDC	24 VDC
Rated current	66.7 mA	40 mA	33.3 mA	22.2 mA	16.7 mA	8.3 mA
Coil resistance	45 Ω	125 Ω	180 Ω	405 Ω	720 Ω	2,880 Ω
Coil inductance (H) (ref. value)	Armature OFF	0.05	0.13	0.19	0.45	3.56
	Armature ON	0.04	0.12	0.17	0.40	3.10
Must set voltage	70% max. of rated voltage					
Must reset voltage	70% max. of rated voltage					
Max. voltage	130% of rated voltage at 70°C					
Power consumption	Approx. 200 mW					

Double-winding Latching, Bifurcated Crossbar Contact Type

Rated voltage	3 VDC	5 VDC	6 VDC	9 VDC	12 VDC	24 VDC	
Set coil	Rated current	66.7 mA	40 mA	33.3 mA	22.2 mA	16.7 mA	8.3 mA
	Coil resistance	45 Ω	125 Ω	180 Ω	405 Ω	720 Ω	2,880 Ω
	Coil inductance (H) (ref. value)	Armature OFF	0.03	0.09	0.12	0.25	1.66
		Armature ON	0.03	0.08	0.11	0.22	1.62
Reset coil	Rated current	66.7 mA	40 mA	33.3 mA	22.2 mA	16.7 mA	8.3 mA
	Coil resistance	45 Ω	125 Ω	180 Ω	405 Ω	720 Ω	2,880 Ω
	Coil inductance (H) (ref. value)	Armature OFF	0.03	0.09	0.12	0.25	1.66
		Armature ON	0.03	0.08	0.11	0.22	1.62
Must set voltage	70% max. of rated voltage						
Must reset voltage	70% max. of rated voltage						
Max. voltage	130% of rated voltage at 70°C						
Power consumption	Set coil: Approx. 200 mW Reset coil: Approx. 200 mW						

- Note:** 1. The rated current and coil resistance are measured at a coil temperature of 23°C with a tolerance of ±10%.
2. Operating characteristics are measured at a coil temperature of 23°C.

■ Contact Ratings

Load	Resistive load (cosφ = 1)	Inductive load (cosφ = 0.4; L/R = 7 ms)
Rated load	0.4 A at 125 VAC; 2 A at 30 VDC	0.2 A at 125 VAC; 1 A at 30 VDC
Contact material	Ag (Au-clad)	
Rated carry current	3 A	
Max. switching voltage	250 VAC, 220 VDC	
Max. switching current	3 A	3 A
Max. switching power	50 VA, 60 W	25 VA, 30 W
Min. permissible load	10 μA at 10 mVDC	

Note: P level: $\lambda_{60} = 0.1 \times 10^{-6}$ /operation

■ Characteristics

Contact resistance	50 mΩ max.
Operate (set*) time	5 ms max. (mean value: approx. 2.9 ms; 48 VDC type: approx. 2.4 ms)
Release (reset*) time	5 ms max. (mean value: approx. 1.3 ms)
Bounce time	Operate: 3 ms max. (mean value: 0.37 ms) Release: 3 ms max. (mean value: 1.12 ms)
Max. operating frequency	Mechanical: 36,000 operations/hr Electrical: 1,800 operations/hr (under rated load)
Insulation resistance	1,000 MΩ min. (at 500 VDC)
Dielectric withstand voltage	1,500 VAC, 50/60 Hz for 1 min between coil and contacts 1,000 VAC, 50/60 Hz for 1 min between contacts of same polarity
Impulse withstand voltage	1,500 V (10 x 160 μs) (conforms to FCC Part 68)
Vibration resistance	Destruction: 10 to 55 Hz, 5-mm double amplitude Malfunction: 10 to 55 Hz, 3.3-mm double amplitude
Shock resistance	Destruction: 1,000 m/s ² Malfunction: 300 m/s ²
Life expectancy	Mechanical: 100,000,000 operations min. (at 36,000 operations/hr) Electrical: 100,000 operations min. (0.4 A at 125 VAC resistive load; 0.2 A at 125 VAC inductive load) 500,000 operations min. (2 A at 30 VDC resistive load; 1 A at 30 VDC inductive load) 200,000 operations min. (3 A at 30 VDC resistive load)
Ambient temperature	Operating: -40°C to 70°C (with no icing) Storage: -40°C to 70°C (with no icing)
Ambient humidity	35% to 85%
Weight	Approx. 2.7 g

*Minimum set and reset signals width is 7 ms min.

■ Approved Standards

UL508 (File No. E41515)/CSA C22.2, No.14 (File No. LR31928)

Contact form	Coil ratings	Contact ratings
SPDT	3 to 48 VDC	0.2 A, 250 VAC (general use) 0.6 A, 125 VAC (general use) 2 A, 30 VDC (resistive) 0.6 A, 125 VDC (resistive, Ag contact only)

Engineering Data

Maximum Switching Power

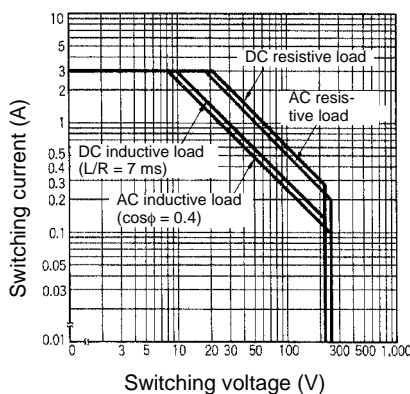

Life Expectancy

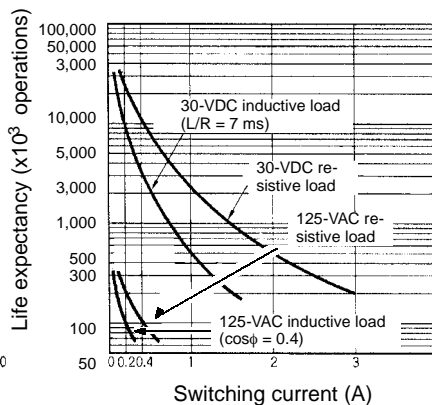

Ambient Temperature vs. Maximum Coil Voltage

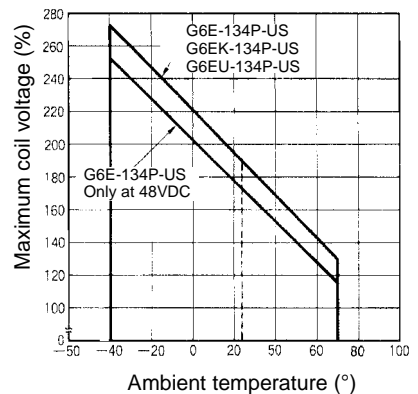

Note: The maximum coil voltage refers to the maximum value in a varying range of operating power voltage, not a continuous voltage.

Dimensions

Note: 1. All units are in millimeters unless otherwise indicated.

2. Orientation marks are indicated as follows:

**G6E-134P-US
G6E-194P-US**

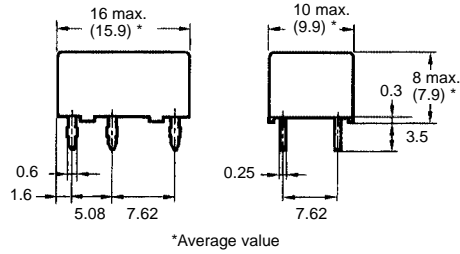
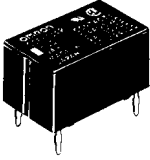

*Average value

**Terminal Arrangement/
Internal Connections
(Bottom View)**

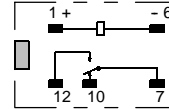

**G6E-134C-US
G6E-194C-US**

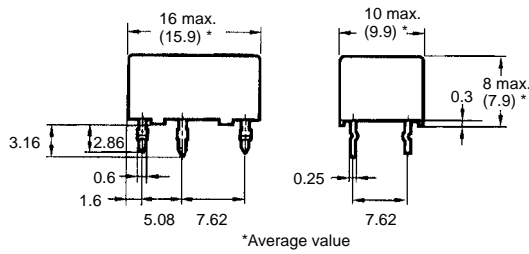
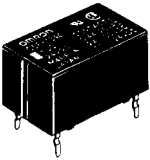

*Average value

**Mounting Holes
(Bottom View)**

Tolerance: ±0.1

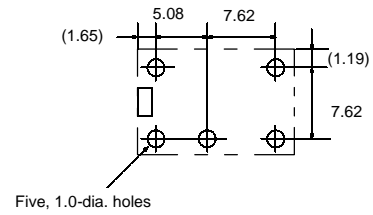

**G6EU-134P-US
G6EU-194P-US**

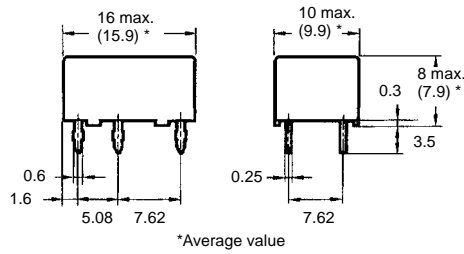
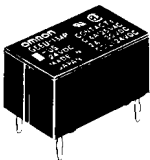

*Average value

**Terminal Arrangement/
Internal Connections
(Bottom View)**

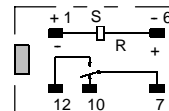

**Mounting Holes
(Bottom View)**

Tolerance: ±0.1

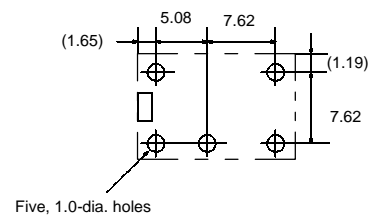

**G6EU-134C-US
G6EU-194C-US**

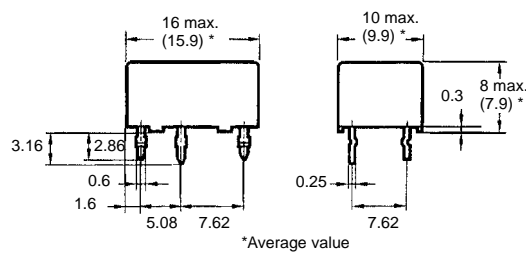
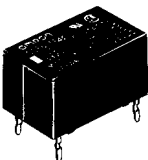

*Average value

**G6EK-134P-US
G6EK-194P-US**

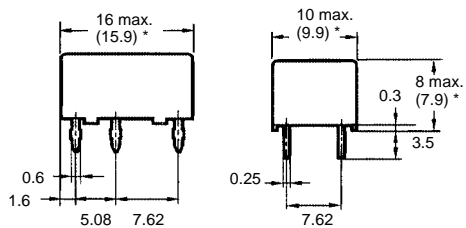
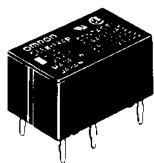

*Average value

**Terminal Arrangement/
Internal Connections
(Bottom View)**

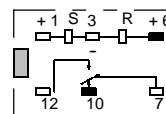

**G6EK-134C-US
G6EK-194C-US**

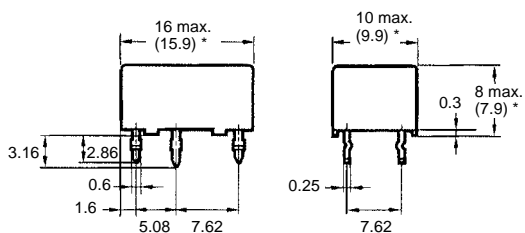
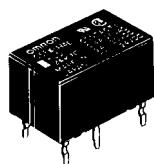

*Average value

**Mounting Holes
(Bottom View)**
Tolerance: ±0.1

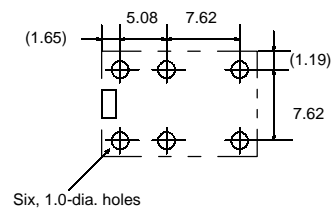

ALL DIMENSIONS SHOWN ARE IN MILLIMETERS.
To convert millimeters into inches, multiply by 0.03937. To convert grams into ounces, multiply by 0.03527.