

■ Single-phase Models

EUN Series

AC Power Controller with Phase-control System Allows Precise Temperature Control

Models with Base-up and Soft-start Functions Available

EH Series

Phase Control System Makes It Possible to Detect Disconnection of Heaters

EC Series

Optimum Device for Controlling Input Power for Pure Metal Heater, and Incorporates Overcurrent Detecting and Single Heater Burnout Detecting Functions

- OMRON's unique design and carefully-selected materials made it possible to produce a compact and lightweight Power Controller.
- Replaceable, easy-to-install Power Device Cartridge assures ease of maintenance.
- Detecting component failures and operating errors.
- On applying for UL, CSA.



Ordering Information

EUN Series

Phase	Applicable load	Level indicator	Base-up function (see note 1)	Soft-start time	Carry current	Rated voltage	Model
Single	Resistive load Heater	Yes	Yes	Approx. 0.5 to 10 sec	20 A	100/110 VAC	G3PX-220EUN
					40 A	200/230 VAC (see note 2)	G3PX-240EUN
					60 A		G3PX-260EUN

Note: 1. The base-up output with a 0-mA temperature controller output (i.e. the temperature controller is OFF) differs from that with a 4-mA temperature controller output. Refer the *Characteristics data* on page 67.

2. When ordering, make sure that the rated voltage is 200/230 VAC because the 200/220-VAC G3PX exists as well.

EH Series

Phase	Applicable load	Level indicator	Single heater burnout detection	Multiple heater burnout detection	Carry current	Rated voltage	Model (see note 1)		
Single	Resistive load Heater	Yes	Yes	No	20 A	100/110 VAC 200/230 VAC (see note 3)	G3PX-220EH-CT03		
					40 A		G3PX-220EH-CT10		
							60 A	G3PX-240EH-CT03	
								G3PX-240EH-CT10	
					Yes (see note 2)		Yes	20 A	G3PX-260EH-CT03
								40 A	G3PX-260EH-CT10
			60 A	G3PX-220EHN-CT03					
				G3PX-220EHN-CT10					
			40 A	G3PX-240EHN-CT03					
				60 A				G3PX-240EHN-CT10	
							G3PX-260EHN-CT03		
							G3PX-260EHN-CT10		

- Note:**
- EH- and EHN-series models are provided with a CT incorporating 30- or 100-cm-long lead wires and Power Device Cartridge. When ordering, specify the length of the lead wires by adding a code to the model number as shown below.
G3PX-2□0EH-CT03: CT with 30-cm-long lead wires
G3PX-2□0EH-CT10: CT with 100-cm-long lead wires
 - Adjusts the multiple heater burnout detection sensitivity of EHN-series models. Enables single heater burnout detection in control of a maximum of five heaters.
 - When ordering, Rated voltage should be made sure if it is for 200/230 VAC. Otherwise 200/220 VAC G3PX is existing.

EC Series

Phase	Applicable load	Level indicator	Constant-current function	Single heater burnout detection	Carry current	Rated voltage	Model (see note 1)	
Single	Resistive load Heater	Yes	Yes	Yes	20 A	100/110 VAC 200/230 VAC (see note 2)	G3PX-220EC-CT03	
					40 A		G3PX-220EC-CT10	
							60 A	G3PX-240EC-CT03
								G3PX-240EC-CT10
					60 A		G3PX-260EC-CT03	
								G3PX-260EC-CT10

- Note:**
- EC-series models are provided with a CT Unit with lead wires (30- or 100- cm in length). When ordering, specify the length of the lead wires by adding a code to the model number as shown below.
G3PX-2□0EC-CT03: CT with 30-cm-long lead wires
G3PX-2□0EC-CT10: CT with 100-cm-long lead wires
 - When ordering, Rated voltage should be made sure if it is for 200/230 VAC. Otherwise 200/220 VAC G3PX is existing.

■ Accessories (Order Separately)

CT Unit

Name	Length of lead wires	Solderless terminals	Applicable models	Model
CT Unit	0.3 m	Yes	G3PX-2□□EH	G32X-CT03
	1 m			G32X-CT10
	0.3 m		G3PX-2□□EHN	G32X-CT03HN
	1 m			G32X-CT10HN
	0.3 m		G3PX-2□□EC	G32X-CT03C
	1 m			

Power Device Cartridge

Name	Carry current	Applicable models	Model
Power Device Cartridge	20 A	G3PX-220E□□	G32X-A20
	40 A	G3PX-240E□□	G32X-A40
	60 A	G3PX-260E□□	G32X-A60

- Note:** The G32X-A is a dedicated Power Device Cartridge for the G3PX.
Refer to *Replacement Parts* on page 75.

Specifications

■ Ratings

Control

Item	G3PX-220EUN/ 240EUN/ 260EUN	G3PX-220EH/ 240EH/ 260EH	G3PX-220EHN/ 240EHN/ 260EHN	G3PX-220EC/ 240EC/ 260EC
Rated voltage	100/110, 200/230 VAC			
Frequency	50/60 Hz (see note 1)			
Input signal for control	External main setting	2 k Ω (type B, 2 W min.)	3 k Ω (type B, 2 W min.)	2 k Ω (type B, 2 W min.)
	Current input	4 to 20 mA (at 1 to 5 V) (Input impedance: 250 Ω) (see note 3)		
	Voltage ON/OFF input	5 to 24 VDC (Input impedance: approx. 20 k Ω)		
	External duty setting	3 k Ω (type B)		
Relay output for alarm	---	SPDT: 8 A at 250 VAC/30 VDC		

- Note:**
- 50/60 Hz (no selector required) (EUN Series)
Terminals 18 and 19 of EHN/EC-series models must be open when the supply frequency is 50 Hz. These terminals must be short-circuited when the supply frequency is 60 Hz.
 - Use the G32X-V2K 2-k Ω Variable Resistor for external main setting on EUN, EC, and EHN (G32X-V3K 3-k Ω for EN-series models).
 - Input 4 to 20 mA or 1 to 5 VDC linear input to the 4 to 20 mA current input terminal.

Output

Model	Applicable load			
	Load voltage range	Load current	Inrush current	Number of phase
G3PX-220E□ G3PX-220E□N	100/110, 200/230 VAC (50/60 Hz)	1 to 20 A (see note)	220 A (60 Hz, 1 cycle)	Single
G3PX-240E□ G3PX-240E□N		1 to 40 A (see note)	440 A (60 Hz, 1 cycle)	
G3PX-260E□ G3PX-260E□N		1 to 60 A (see note)	440 A (60 Hz, 1 cycle)	

- Note:** The G3PX-2□□EHN (model with multiple heater burnout detecting function) and G3PX-2□□EC (constant-current model) require 20% min. of the rated current to detect a short mode failure. EC-series models detect an open mode failure if the load current has dropped to 80% of the rated value. A short mode failure will be detected if the current has risen to 20% of the rated value.

■ Characteristics

EU/EH Series

Item	G3PX-220EUN/ 240EUN/260EUN	G3PX-220EH/240EH/260EH	G3PX-220EHN/ 240EHN/260EHN
Operating voltage range	±10%		
Operating frequency range	±1 Hz		
Output voltage adjustable range	0% to 95%		
Internal duty setting range	0% to 100%	10% to 100% (see note 1)	0% to 100%
External duty setting range	0% to 100%	10% to 100% (see note 1)	0% to 100%
Start-up time (see note 2)	Approx. 0.5 to 10 s (see note 3)	Approx. 0.1 to 1 s (see note 3)	Approx. 0.5 to 10 s (see note 3)
Base-up range	0% to 90%	---	
Multiple heater burnout detection	---		20% max. (see note 4)

Item	G3PX-220EUN/ 240EUN/260EUN	G3PX-220EH/240EH/260EH	G3PX-220EHN/ 240EHN/260EHN
Min. phase detection	---	Approx. $1/6 \pi$	
Min. phase setting	---	---	Approx. $1/6 \pi$
Min. load current for ON error detecting	---	1 A	30% max. of rated current (see note 5)
Abnormality detection time	---	0.1 s max.	1 s max.
Voltage drop with output ON	1.6 V max. (RMS)		
Leakage current	10 mA max. at 100/110 VAC, 20 mA max. at 200/230 VAC		
Insulation resistance	100 M Ω min. (at 500 VDC)		
Dielectric strength	2,000 VAC, 50/60 Hz for 1 min.		
Vibration resistance	Malfunction: 10 to 55 Hz, 10G		
Shock resistance	Malfunction: 300 m/s ²		
Ambient temperature	Operating: -25°C to 65°C (with no icing or condensation) Storage: -10°C to 55°C (with no icing or condensation)		
Ambient humidity	Operating: 45% to 85%		
Weight	G3PX-220EUN: approx. 1.1 kg G3PX-240EUN: approx. 1.4 kg G3PX-260EUN: approx. 1.7 kg	G3PX-220EH: approx. 1.1 kg G3PX-240EH: approx. 1.4 kg G3PX-260EH: approx. 1.7 kg	G3PX-220EHN: approx. 1.2 kg G3PX-240EHN: approx. 1.5 kg G3PX-260EHN: approx. 1.8 kg

- Note:**
1. Duty setting does not complete to the OFF state (i.e. 10% remains).
 2. The start-up time is factory-set to 1 s on the EH Series, approx. 0.5 s on the EHN and EC Series.
 3. This is the initial start-up time with a 100% duty setting.
 4. Detection is effective when the set current is reduced by 20% or more.
 5. The minimum set value in the G3PX-220EHN is 6 A. If a lower value is required, increase the number of wiring turns around the CT.

EC Series

Item	G3PX-220EC	G3PX-240EC	G3PX-260EC
Operating voltage range	$\pm 10\%$		
Operating frequency range	± 1 Hz		
Output voltage adjustable range	0% to 95%		
Internal duty setting range	0% to 100%		
External duty setting range	0% to 100%		
Start-up time	Approx. 0.5 to 10 s		
Min. load current for ON error detecting	20% max. of rated current		
Current limit range	0% to 100%		
Excess current detection	Peak current of 110 A within 1 cycle	Peak current of 220 A within 1 cycle	Peak current of 330 A within 1 cycle
Constant current	$\pm 3\%$ max. with 10-time increment of load value $\pm 3\%$ max. with $\pm 10\%$ change of voltage		
Abnormality detection time	1 s max.		
Voltage drop with output ON	1.6 V max. (RMS)		
Leakage current	10 mA max. at 100/110 VAC, 20 mA max. at 200/220 VAC		
Insulation resistance	100 M Ω min. (at 500 VDC)		
Dielectric strength	2,000 VAC, 50/60 Hz for 1 min.		
Vibration resistance	Malfunction: 10 to 55 Hz, 10G		
Shock resistance	Malfunction: 300 m/s ²		
Ambient temperature	Operating: -25°C to 65°C (with no icing or condensation) Storage: -10°C to 55°C (with no icing or condensation)		
Ambient humidity	Operating: 45% to 85%		
Weight	G3PX-220EC: approx. 1.1 kg G3PX-240EC: approx. 1.4 kg G3PX-260EC: approx. 1.7 kg		

Engineering Data

The following data is for an ambient temperature of 25°C.

Output Characteristics

G3PX-EUN/EH/EHN Models

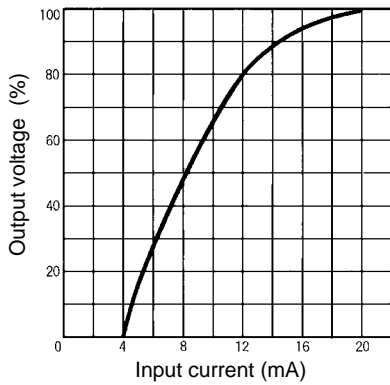

G3PX-EC

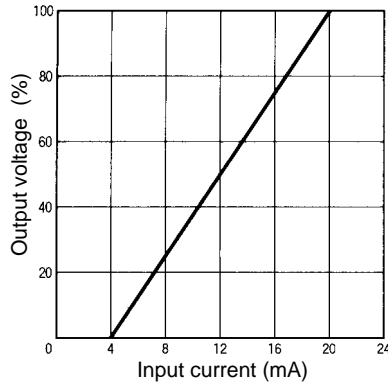

Duty Setting

G3PX-EUN/EH/EHN Models

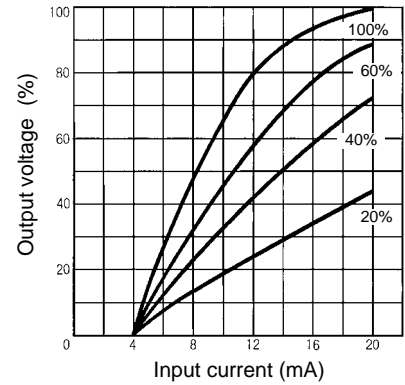

Base-up Characteristics

G3PX-2□0EUN Models

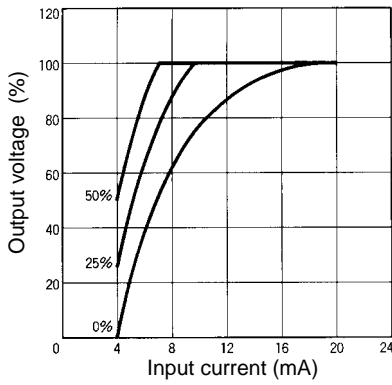

Load Current vs. Ambient Temperature

G3PX-220E□ Models

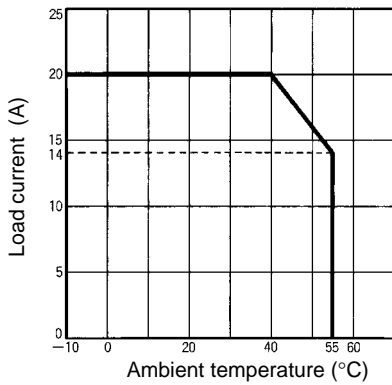

G3PX-240E□ Models

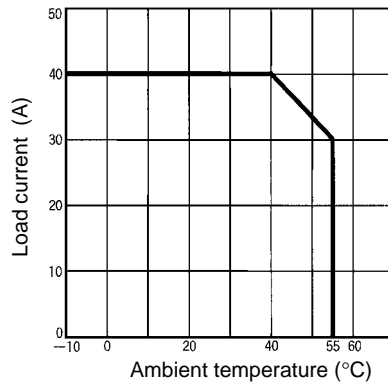

G3PX-260E□ Models

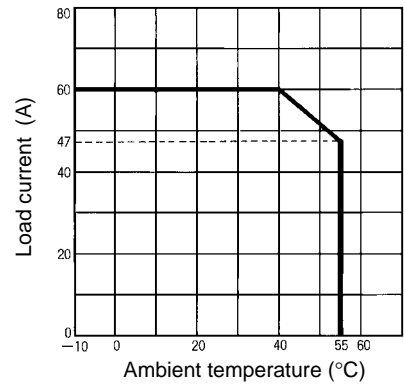

Withstand Inrush Current

G3PX-220E Models

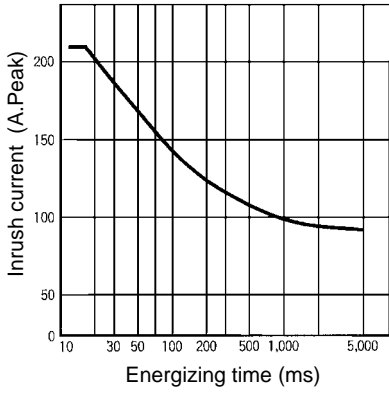

G3PX-240E Models

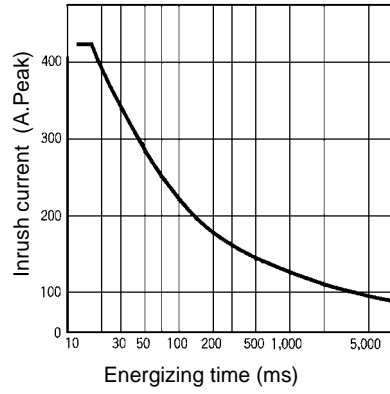

G3PX-260E Models

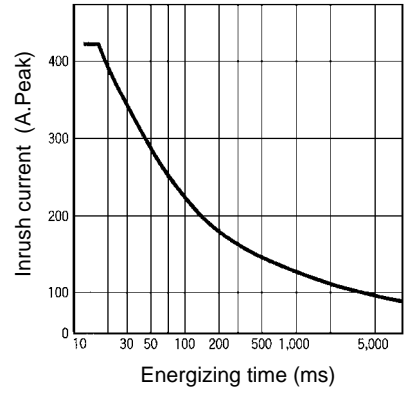

Note: The above are possible on condition that the G3PX is in non-repetitive operation. If the G3PX is in repetitive operation, reduce the applied current to half.

Nomenclature

Single-function Model (EUN-series Model)

G3PX-2□0EUN

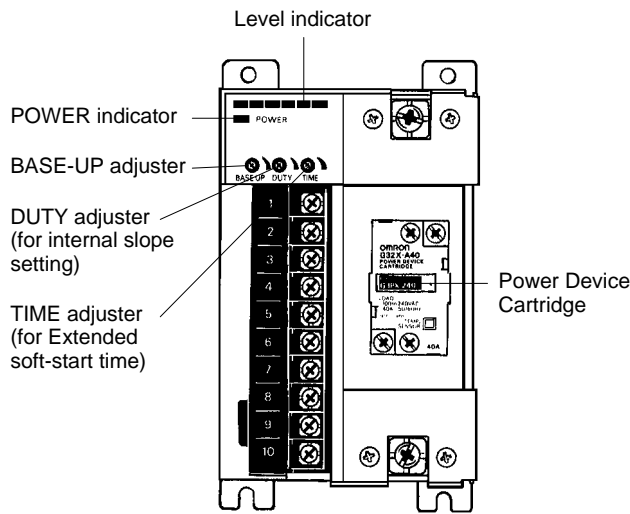

Multiple Heater Burnout Detection (EHN-series Model)

G3PX-2□0EHN-CT□□

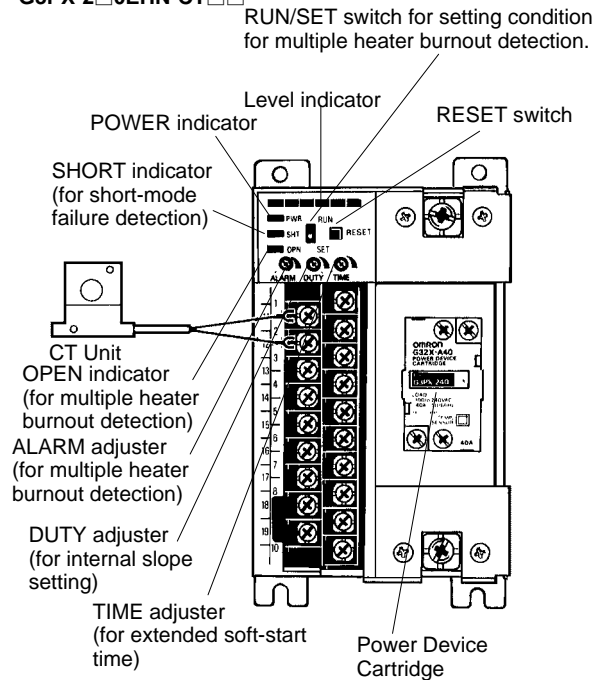

Single Heater Burnout Detection (EH-series Model)

G3PX-2□0EH-CT□□

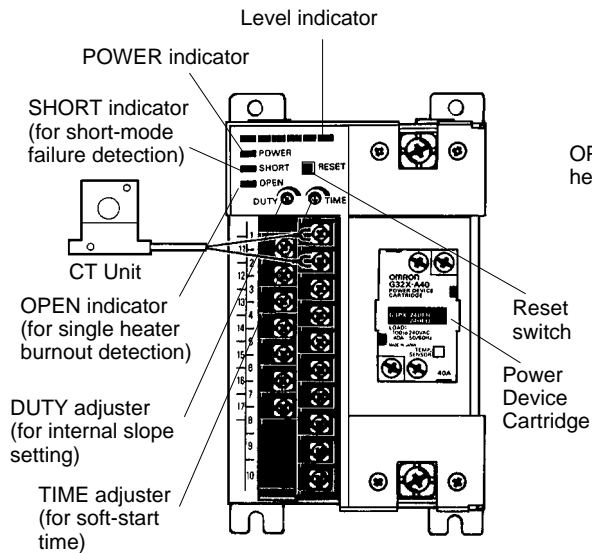

Constant-current Model (EC-series Model)

G3PX-2□0EC-CT□□

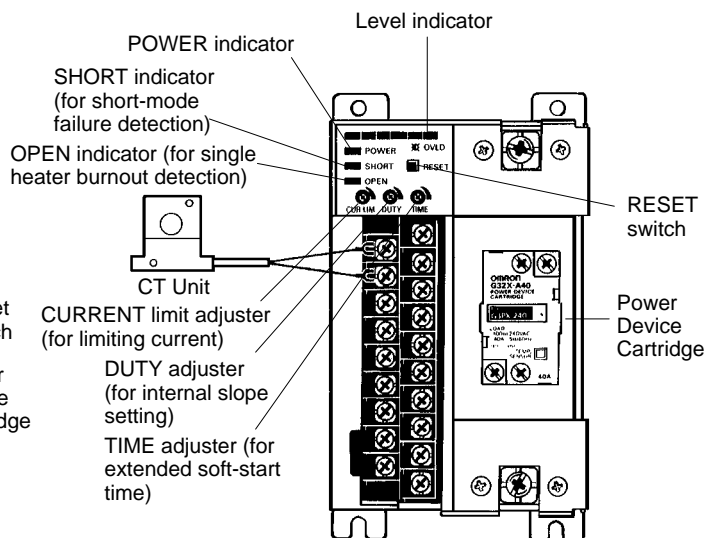

Operation

■ Error Detecting Function

Wiring

Single-phase Models

All G3PX-2□0EH/EHN/EC-series models incorporate terminals 11 and 12 for the CT Unit, 13 and 14 for the external reset switch, and 16 and 17 for relay output as well as power/input terminals 1 through 10.

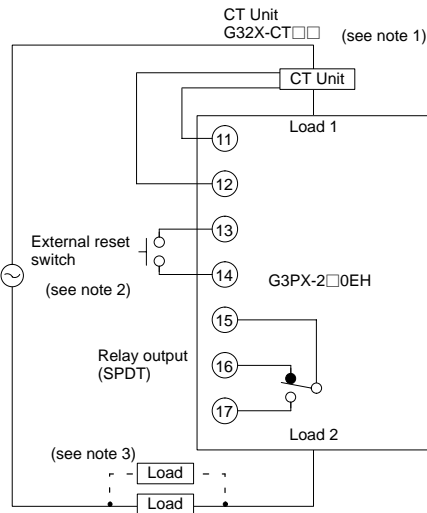

- Note:**
1. Connect either the black or white lead wire of the CT Unit to terminal 11 and the other lead wire to terminal 12. The G3PX will malfunction if you do not connect the CT Unit to the G3PX.
 2. The rated current and voltage of G3PX models when reset are as follows:
EH-series models: 12 mA at 12 VDC
EHN- and EC-series models: 1 mA at 12 VDC
 3. For more than one heater.

Output

Single-phase Models

The following illustrations show the condition of the G3PX LED indicators when the G3PX detects heater burnout, a short-mode failure (ON failure of components), or overcurrent (EC-series constant-current models only). The indicator and relay output signals are reset with the internal or external reset switch provided that the error condition has been remedied.

1. When EH/EHN/EC-series models detect single or multiple heater burnout, the OPEN indicator is lit and the SPDT relay output is ON.
- Note:** When the G3PX detects heater burnout, the Level indicator will be OFF regardless of the G3PX input condition. The red OPEN indicator will be lit. EHN-series models, however, will continue operating with level indication.

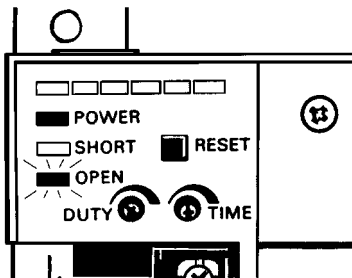

2. When EH/EHN/EC-series models detect a short-mode failure, the SHORT indicator is lit and the SPDT relay output is ON.

With continuous load current.

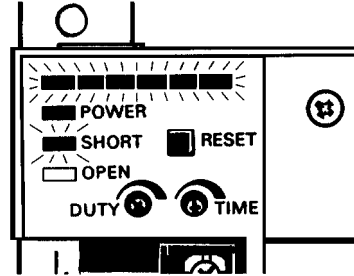

With load current shut off.

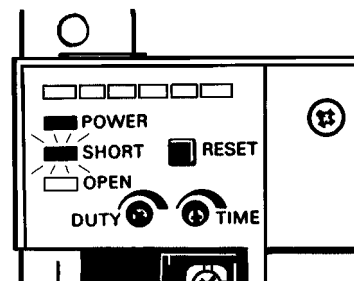

- Note:** When the G3PX detects a short-mode failure, all LEDs of the Level indicator and red SHORT indicator are lit. When you use a breaker to disconnect the load with the relay output, all LEDs of the Level indicator will be OFF regardless of the input to the G3PX.
3. When EC-series models detect an overcurrent, the Level indicator will flash and the SPDT relay output is ON. The input signal will be shut off.

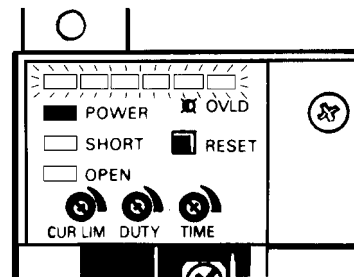

- Note:** When resetting, leave power supply terminals 10 to 9 or 8 ON.

■ Wiring

Main Circuit

Single-phase Models

The following illustrations show connection examples:

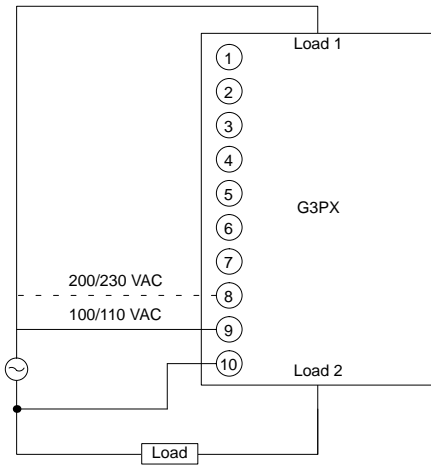

Note: Use a single power supply for the G3PX and the load.

Setting Circuit

Analog Control

Single-phase Models

1. A Temperature Controller with 4- to 20-mA output is used to control the G3PX.

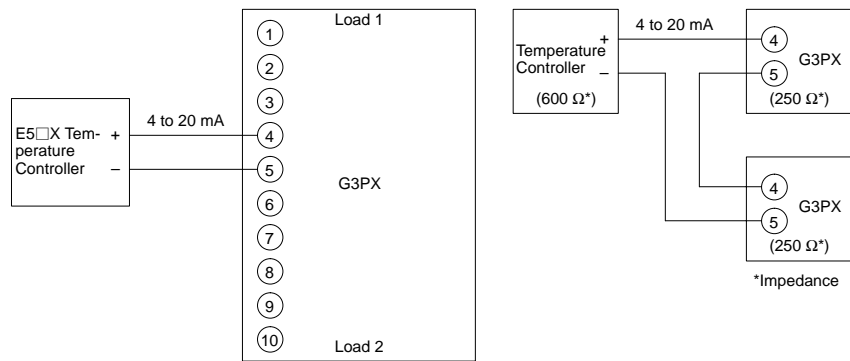

Note: Two G3PX models can be connected in series to OMRON's single Temperature Controller (with an internal impedance of 600 Ω) with a current output.

2. A Temperature Controller with an output of 7 to 20 mA is used with the G3PX to change the duty.

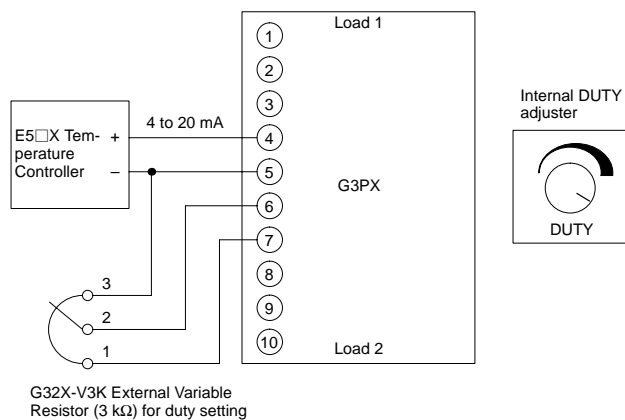

Note: You can change the duty with the external or internal ramp adjuster.

ON/OFF Control

Single-phase Models

1. A Temperature Controller is used to change the duty of G3PZ.

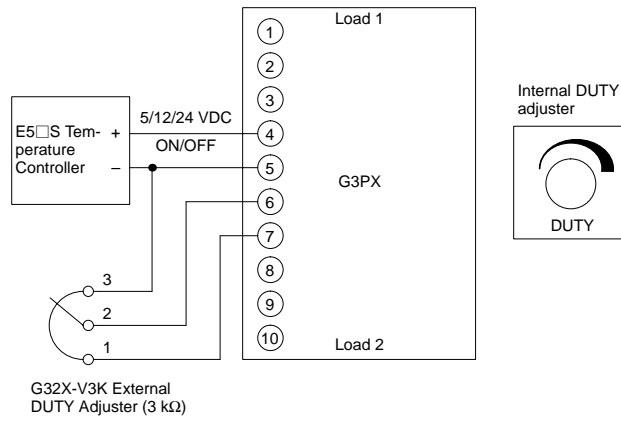

Note: You can change the duty with the external or internal variable resistor.

2. A Temperature Controller (with a voltage output) is used to control several G3PXs.

Temperature Controller specifications	No. of G3PX
E5□X: 40 mA at 12 V	20 sets
E5□S: 20 mA at 12 V	20 sets
20 mA at 5 V	20 sets
10 mA at 5 V	20 sets

Connection Example

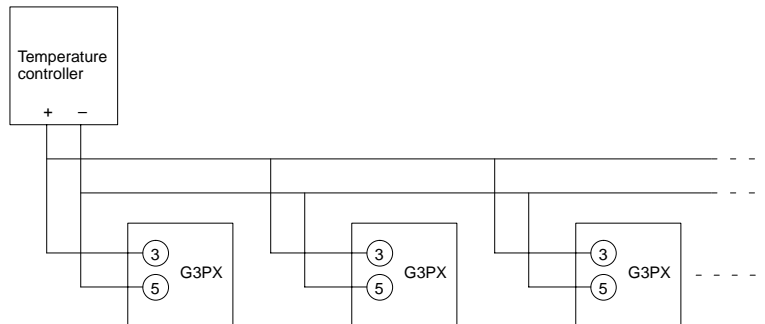

3. A Temperature Controller (with a relay output) is used to vary the duty of G3PX.

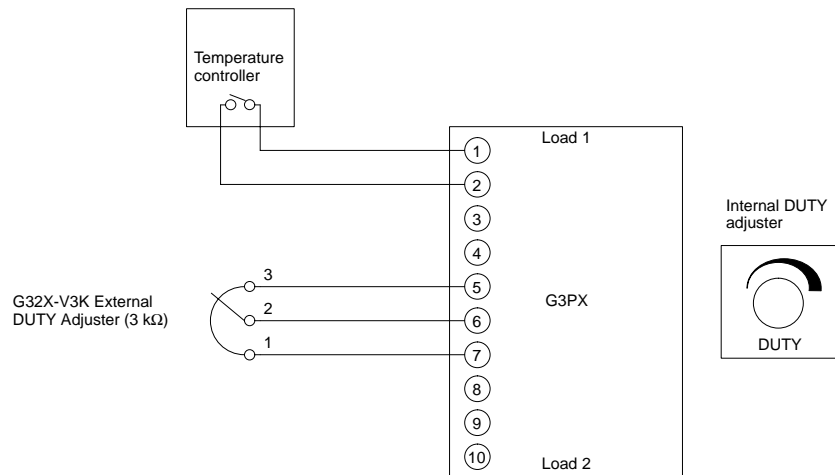

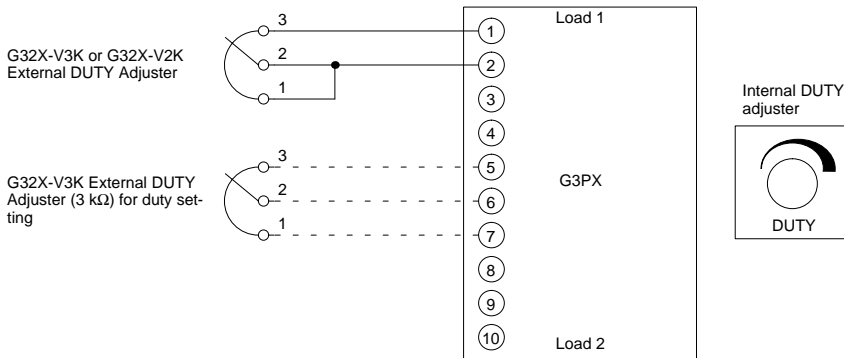
Manual Control**Single-phase Models**

Note: Delicate duty adjustment is possible with the external or internal resistor. Use a right DUTY adjuster (2- or 3-kΩ type) according to the G3PX model as follows:
 G32K-V3K (3 kΩ) for EH-series models
 G32X-V2K (2 kΩ) for EUN-, EHN-, and EC-series models

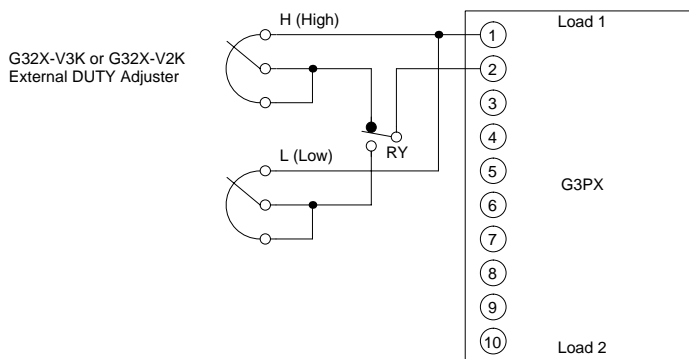
Two-position Control**Single-phase Models**

- Note:**
1. A temperature controller with relay output or a single relay can be used with the G3PX in two-position (high-and low-position) control, in which case the relay contact current is 30 mA at 12 VDC with the External DUTY Adjuster set to 0 Ω.
 2. Use a right DUTY adjuster (2- or 3-kΩ type) according to the G3PX model as follows:
 G32X-V3K (3 kΩ) for EH-series models
 G32X-V21K (2 kΩ) for EUN-, EHN-, and EC-series models.

Setting of Base-up Output (G3PX-2□0EUN Series)

The base-up output can be adjusted with the base-up adjuster knob. It is also possible to control the base-up output for the full scale of 4 to 20-mA input current by adjusting the duty adjuster. Refer to *Engineering Data* on page 67 for the base-up characteristics.

G3PX-2□0EHN Series (Multiple Heater Burnout Detection Model)**Setting**

1. Use the G32X-CT□□HN CT Unit and make sure that the G3PX is wired correctly.
2. The G3PX initially set is shown in the following illustration. Make sure that the RUN/SET switch has been set to SET. Make sure that the DUTY adjuster has been turned clockwise to the maximum.
3. Adjust the sensitivity. Turn the ALARM adjuster and set to the position where the OPEN indicator is lit. Stop turning the ALARM adjuster as soon as the indicator is lit to complete the setting.

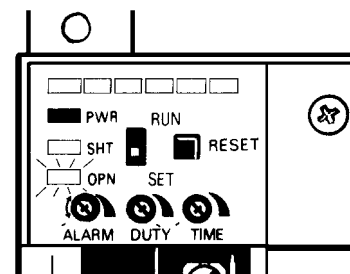
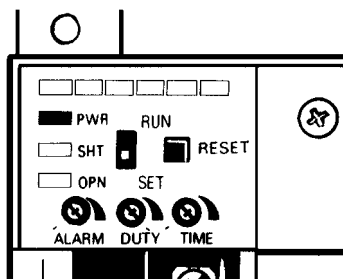

4. Set the RUN/SET switch to RUN.
When all settings have been finished, the OPEN indicator is OFF.

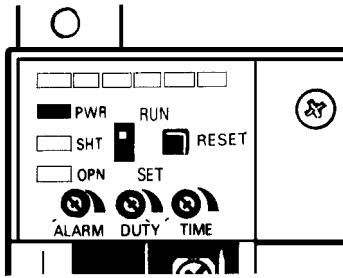

- Note:**
1. The G3PX can control any part of the phase as long as the controlled phase is approximately $1/6\pi$ or more in width.
 2. Be sure to prepare terminals 18 and 19 corresponding to the supply frequency of 50 Hz or 60 Hz. Otherwise, a setting error will result in a malfunction regardless of the RUN/SET switch setting.
When the error has occurred, turn the ALARM adjuster counterclockwise to the minimum setting, reset the G3PX, and readjust.

■ Replacement Parts

G32X-A Power Device Cartridge

The temperature indicator will be lit in red if the power element is damaged. If the power element is damaged due to overcurrent or other reasons, the power element and its peripheral parts can be replaced.

The power element and its peripheral parts can be replaced without disconnecting the wires of the G3PX.

Improve the heat radiation of the G3PX before replacing the Cartridge.

The temperature indicator will not be lit in red if the G3PX has overcurrent due to load short-circuiting or other reasons over a short time.

Appearance

G32X-A20

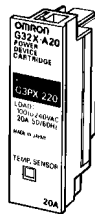

G32X-A40

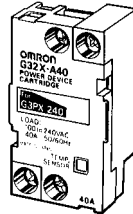

G32X-A60

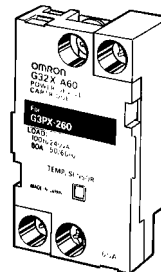

Replacement of G32X-A20 Power Device Cartridge

Use the special tool (provided) to extract the Cartridge for replacement with a new one.

Extraction

Follow the procedures below to dismount the Power Device Cartridge from the G3PX.

1. Switch off the power.
2. Remove the terminal cover.
3. Hook the tool on the indented portions of the Power Device Cartridge as shown in the illustration below and pull up the Power Device Cartridge vertically.

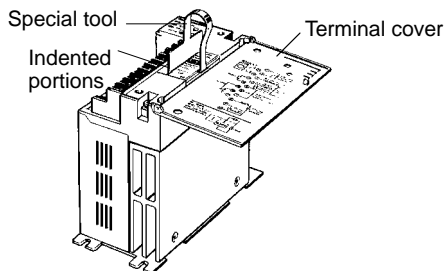

3. Insert the Cartridge into the opening of the G3PX so that the letters on the Cartridge and those on the G3PX are in the same direction and sides A and B are even.

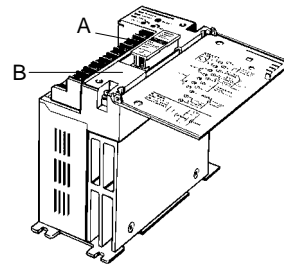

4. Attach the terminal cover.
5. Switch on the power and check the G3PX to be sure it works properly.

G32X-A40/60

The G32X-A40 and G32X-A60 are secured with screws.

Extraction

The procedures for dismounting the Power Device Cartridge are as follows:

1. Switch off the G3PX.
2. Remove the terminal cover.
3. Be sure to turn off the G3PX and loosen the screws located in the upper center and lower center. These screws are connected to terminals 1 and 2.

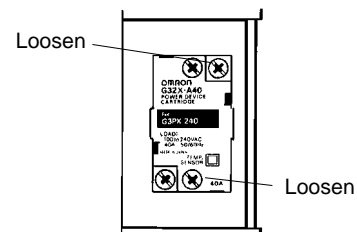

Mounting

The procedures for mounting the Power Device Cartridge are as follows:

1. Apply silicone grease (provided with the G32X-A) to the entire surface of the heat radiator.
2. Make sure there is no dust or pieces of wire on the heat radiators of the G32X-A or the G3PX.

4. Loosen the screws on both corners.

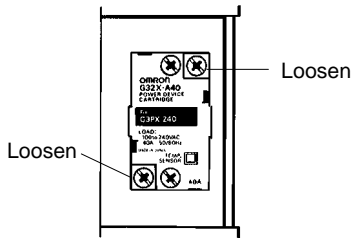

5. Hold the indented part of both corners to dismount the Cartridge.

3. Insert the Cartridge into the opening of the G3PX so that the letters on the Cartridge and those on the G3PX are in the same direction and sides A and B are even.

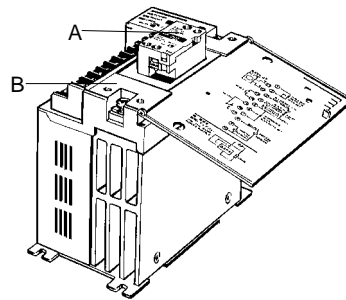

Mounting

1. Apply silicone grease (provided with the G32X-A) to the entire surface of the heat radiator.
2. Make sure there is no dust or pieces of wire on the heat radiators of the G32X-A or the G3PX.

4. Tighten the screws on both corners with a tightening torque of 0.59 to 0.78 N • m.
5. Tighten the center screws of the G3PX with a tightening torque of 0.59 to 0.78 N • m.
6. Attach the terminal cover.
7. Switch on the power and check the G3PX to be sure it works properly.

External Variable Resistor

The G32X-V3K and G32X-V2K are provided with a set consisting of adjuster, knob, and nameplate.

Resistive value (see note 1)	Model
3 kΩ	G32X-V3K (see note 2)
2 kΩ	G32X-V2K

- Note:**
1. The G32X-V3K is equivalent to the conventional G32X-VR.
 2. Resistive Value

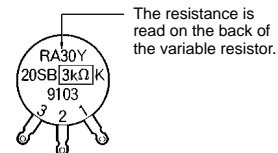

External DUTY Adjuster

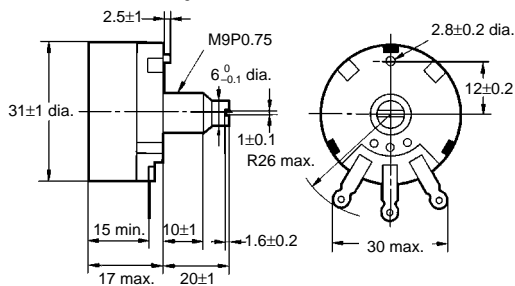

Knob

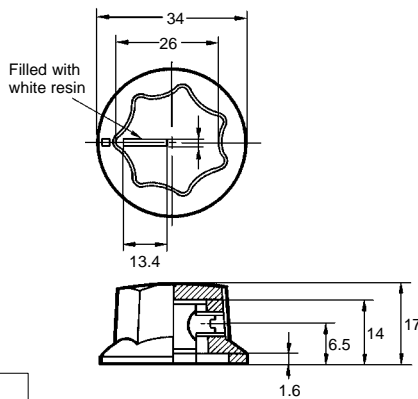

Mounting Holes

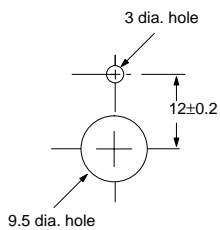

Nameplate

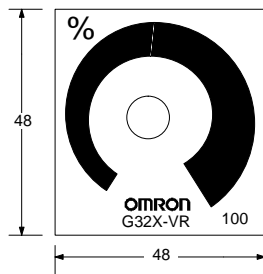

Dimensions

Note: All units are in millimeters unless otherwise indicated.

Single-phase Models

G3PX-220E Series

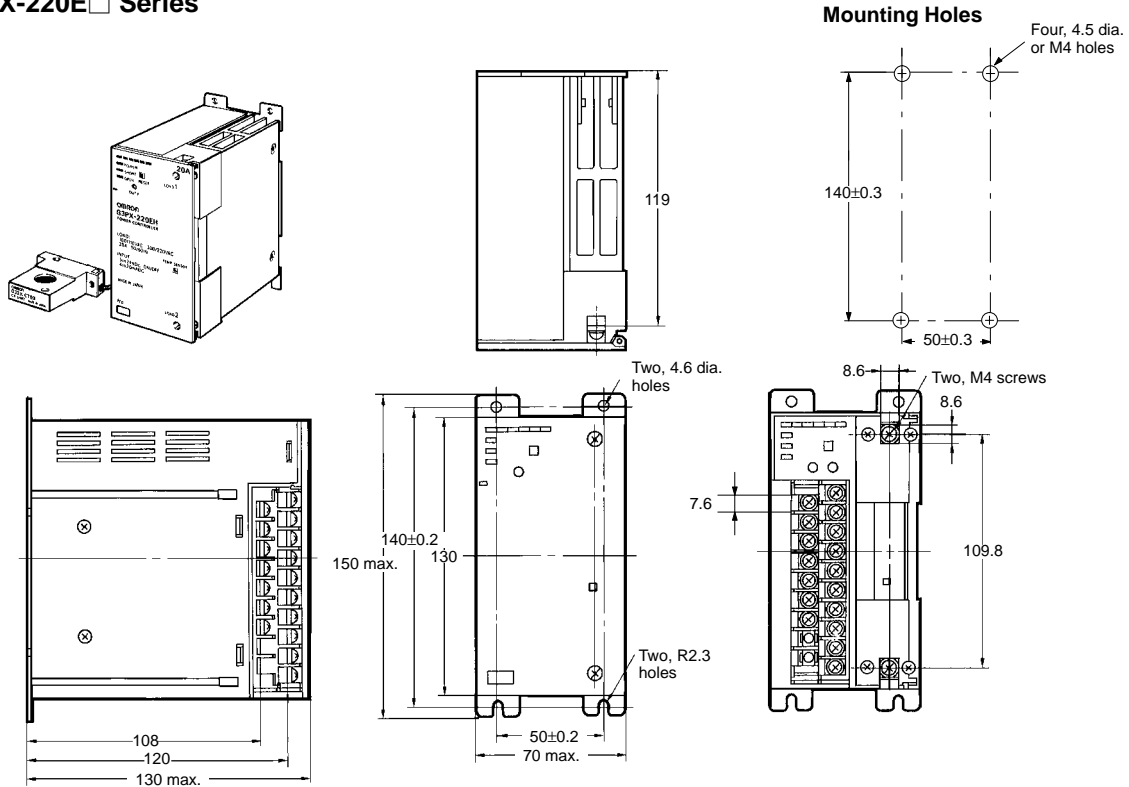

G3PX-240E Series

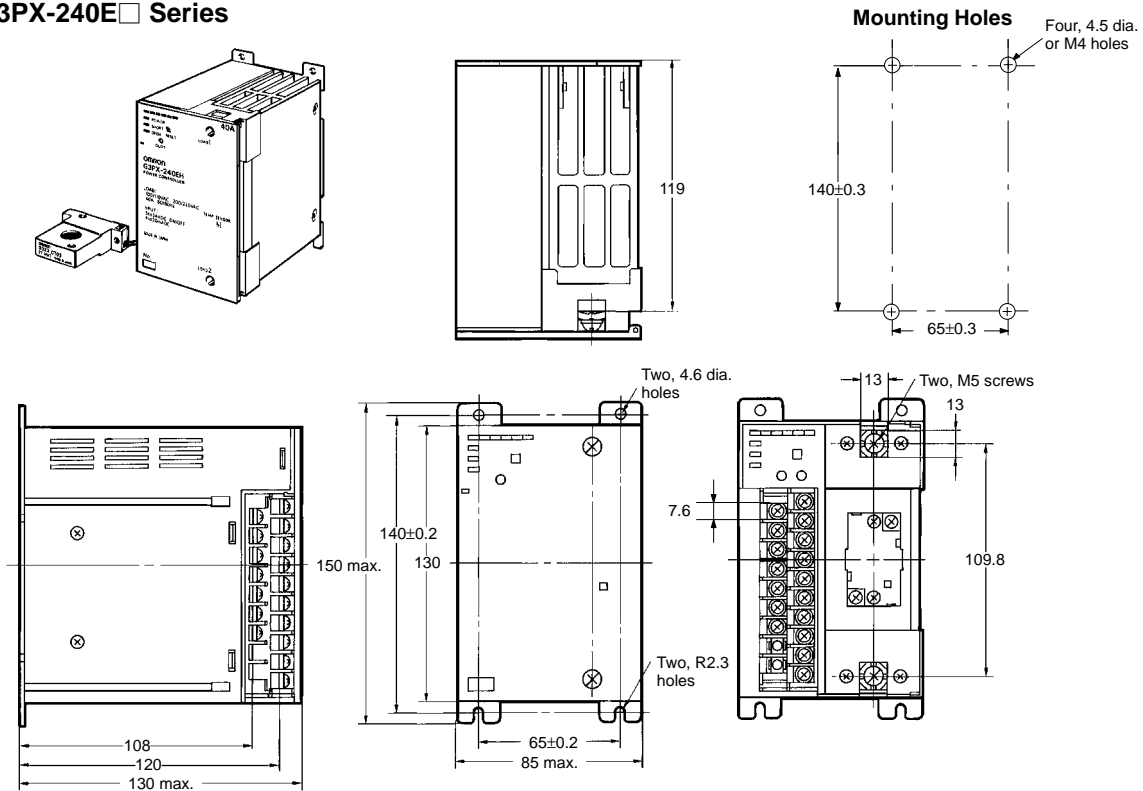

G3PX-260E□ Series

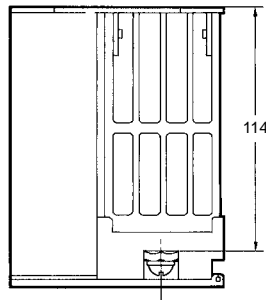
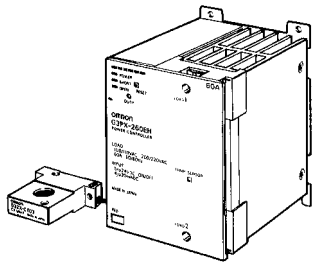

Mounting Holes

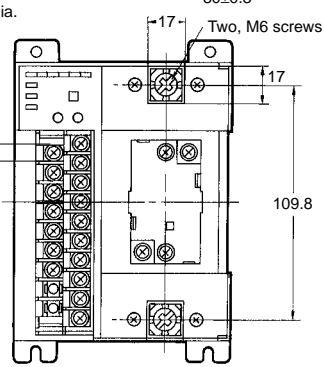
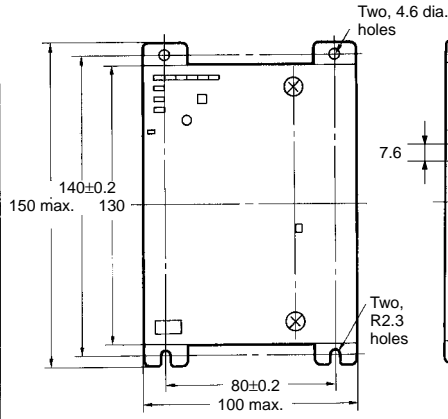
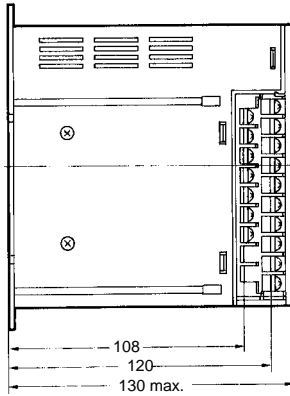
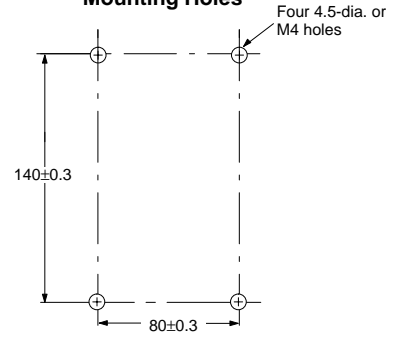

G32X-CT03□ Series
G32X-CT10□ Series

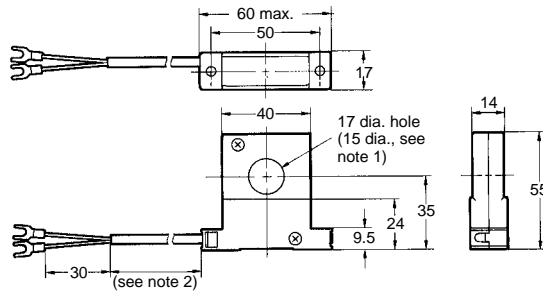
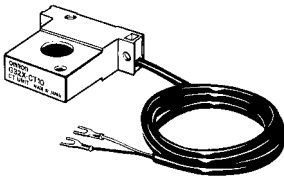

Mounting Holes

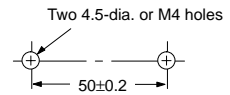

- Note:**
1. Color of the hole
EH Series: Black
EHN Series: White
EC Series: Light gray
The size of the hole of CT Units for EC- and EHN-series models is 15 dia.
 2. The G32X-CT03□ incorporates 30-cm solderless terminals and the G32X-CT10□ incorporates 100-cm solderless terminals.

Installation

Terminal Arrangement

Single-phase Models

G3PX-220EUN
G3PX-240EUN
G3PX-260EUN

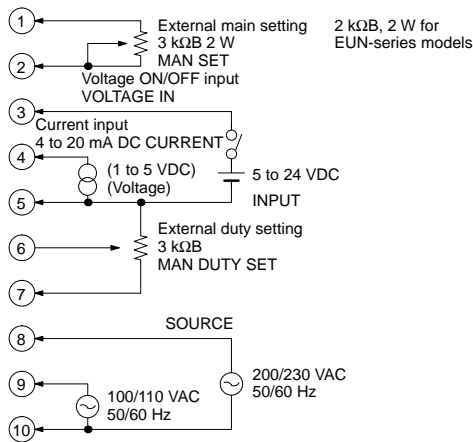

G3PX-220EH
G3PX-240EH
G3PX-260EH

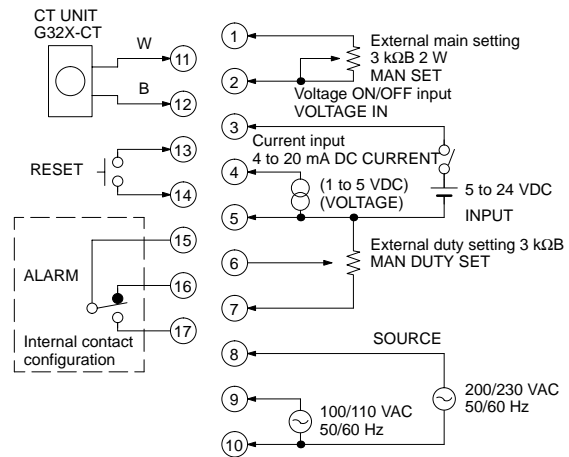

G3PX-220EHN/220EC
G3PX-240EHN/240EC
G3PX-260EHN/260EC

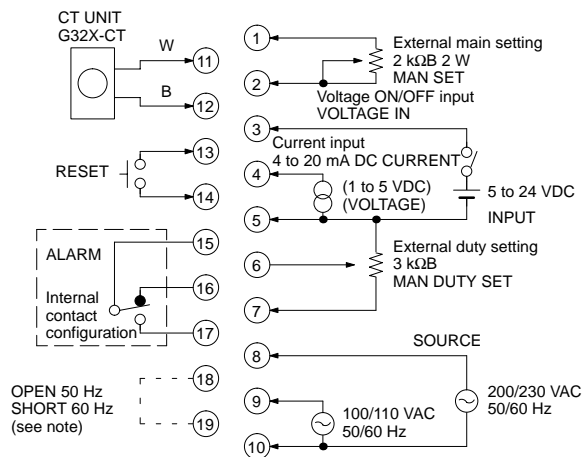

Note: Open the terminals for 50 Hz or short-circuit the terminals for 60 Hz. When the product is shipped, the terminals are short-circuited using a short-circuiting bar to set to 60 Hz. When using at 50 Hz, remove the short-circuiting bar.

Precautions

■ Correct Use

Load

Only resistive loads can be connected to the G3PX. Contact your OMRON representatives if it is necessary to connect inductive or transformer loads.

Mounting

The three-phase, 60-A G3PX weighs approximately 5 kg. Pay utmost attention when mounting the G3PX so that the G3PX will not fall thus resulting in injury.

Vertical Mounting

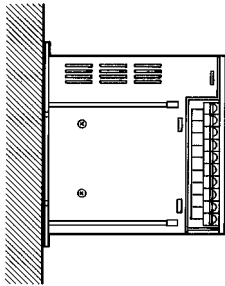

Flat Mounting

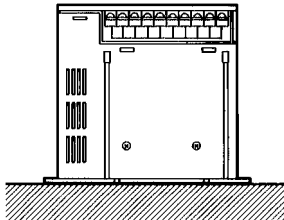

Note: In the case of flat mounting, the 30% derating of the load current is required.

Close Mounting Example (Single-phase Models)

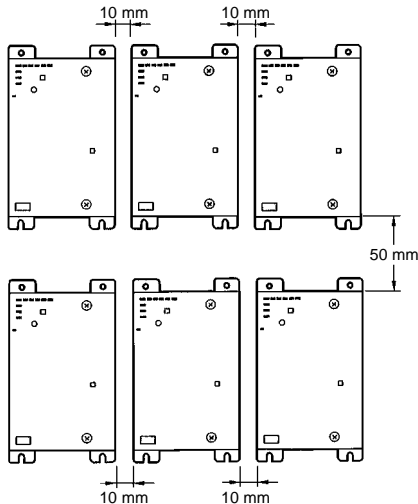

Note: Make sure that there is a space of at least 50 mm vertically and at least 10 mm horizontally between adjacent single-phase models.

Wiring

Make sure that the lead wires are thick enough according to the current.

Be sure to turn off power to the G3PX when wiring. The G3PX has current leakage although the G3PX is turned off if the power supply is connected to the G3PX, which may give an electric shock.

Do not wire power lines or high-tension lines along with the lines of the G3PX in the same conduit, otherwise the G3PX may be damaged or malfunction due to induction. Be sure to wire the lines of the G3PX separated from power lines or high-tension lines or laid in an exclusive, shielded conduit.

Tightening Torque

Apply the following tightening torque.

Output terminal:

20-A model: 1.47 N · m

40-A model: 2.45 N · m

60-A model: 4.12 N · m

Terminal block:

Single-phase model: 0.98 N · m

Be sure to protect the terminals with the protective cover after wiring.

Wiring for Error Detection

If a contactor is employed and operated with the relay output signal of the G3PX for error detection, make sure that the G3PX is closer to the power supply than the contactor.

Instruments

Instrument	Remarks
Thermal type	Available
Digital type displaying root-mean-square values	
Moving-iron type	
Rectifier type	Not available (not precise enough)
Multimeter	
Digital multimeter	

The instruments are used for displaying room-mean-square voltage and current values of the AC circuitry.

Operation Monitoring

The level indicator just indicates the phase of the load and it is not highly precise.

Ramp Setting

There is a decrease in ramp if the internal DUTY adjuster is turned counterclockwise.

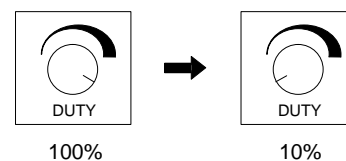

If the External DUTY Adjuster is used, set the Internal DUTY Adjuster to 100%.

CT Unit

The CT Unit varies with the G3PX-series model. Use the following CT Units in combination with the G3PX models.

G3PX-2□0EH Series: G32X-CT□□

G3PX-2□0EHN Series: G32X-CT□□HN

G3PX-2□0EC Series: G32X-CT□□C

If any of the following models is used and the actual load current is 50% of the maximum rated load current or lower, increase the number of turns of the wire around the CT Unit.

G3PX-20EHN Series (multi-heater burnout detective models)
G3PX-20EC Series (constant current)

For example, make two turns if the actual load current is 50% of the maximum rated load current and four turns if the actual load current is 25% of the maximum rated load current.

If the G3PX is a constant current model, do not increase the number of turns of the wire around the CT Unit excessively, otherwise the overcurrent detective function may operate by mistake.

External DUTY Adjuster

Use the External DUTY Adjuster with a resistance of 2 kΩ or that with a resistance of 3 kΩ according to the G3PX-series model in use. Refer to the following combinations.

G3PX-2□EH Series: G32X-V3K (3 kΩ)
G3PX-2□0EUN Series
G3PX-2□0EC Series

Base-up Function

If the model in use has the model number suffix "EUN," the base-up function is available.

The base-up output of the G3PX with a temperature controller output of 0 mA (i.e., the temperature controller is turned off) and that of the G3PX with a temperature controller output of 4 mA are different from each other.

Power Device Cartridge

Do not apply power to the G3PX with the Power Device Cartridge dismounted.

Heater Burnout Detection

EH and EHN Models

The heater burnout detective function is not available for detecting the phase less than the following.

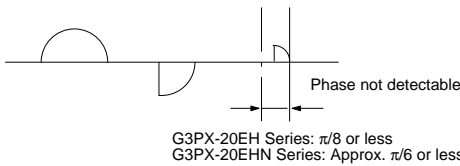

Power Supply

Single-phase Models Only

Do not apply 200 V to the 100-V terminals, otherwise the thermal fuse of the built-in transformer will be blown and the G3PX will not operate.

Others

It is not possible to use three single-phase models for three-phase load control.

If three-phase power supply is used for single-phase models operating in parallel, make sure that the two phases supplied to all the single-phase models are the same.

Troubleshooting

Check the following if the G3PX does not operate or has difficulty in temperature control.

- The load does not turn on with 100% input.
Check the default internal ramp setting.



Make sure that the adjuster is set to the farthest clockwise position.

Also check the current limit adjuster if the G3PX is a constant DC model.

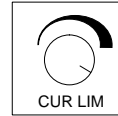

- The G3PX does not operate or is in abnormal operation.
Make sure that all input terminals are connected properly with no mistakes in polarity.
Make sure that the internal DUTY adjuster is not set to the farthest clockwise position.
Make sure that the frequency used by the G3PX (i.e., 50 or 60 Hz) is set properly. (This applies to the EC, and EHN models.)
- The G3PX malfunctions if the external adjusters are turned.
Make sure that the numbers on the external adjusters coincide with the corresponding terminal numbers on the G3PX.
Make sure that the 2-kΩ and 3-kΩ DUTY adjusters are connected correctly.

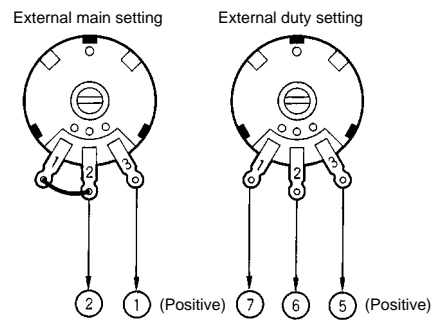

- Temperature control with a Voltage-output Temperature Controller is not smooth.

Make sure that the controlled soft-start up/down time has been adjusted properly. If not, turn the TIME adjuster counterclockwise to the minimum setting to reduce the controlled start-up/down time.

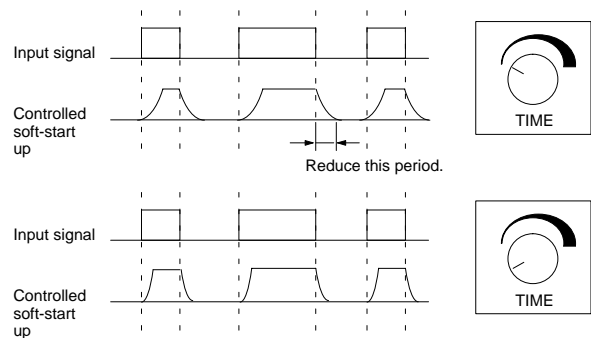

- The Level indicator is not OFF with a 0% input signal (G3PX-2□0EUN Series).

Make sure that the BASE UP adjuster has been turned counterclockwise to the minimum setting.

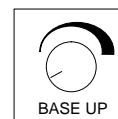

Make sure that the adjuster is turned counterclockwise to the minimum setting.

- The OPEN indicator of a multiple heater burnout detection model is lit at the initial stage (G3PX-2□0EHN Series).

Make sure that the initial settings are OK. If not, readjust the G3PX.

Make sure that terminals 18 and 19 are open if the supply frequency is 50 Hz. These terminals must be short-circuited if the supply frequency is 60 Hz.

Make sure that the load current is large enough.

- The Level indicator LEDs of a constant-current model are all lit and no power control operation is possible.

Make sure that the load current is large enough.

Countermeasure 1: Adjust the CUR LIM adjuster so that the LED on the farthest right of the Level indicator is OFF.

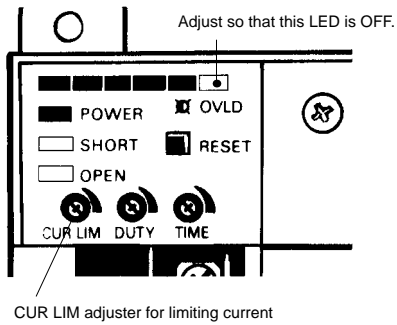

Countermeasure 2: When the supply current is less than 50%, increase the number of turns. When the supply current is 50% of the rated current, the wires must be coiled twice on the CT Unit.

When the supply current is 25% of the rated current, the wires must be coiled three to four times on the CT Unit.

- No reset will be performed even if the RESET button is pressed. Check whether the RESET button is pressed while there is nothing input into power supply terminals 8 and 10 or 9 and 10 of the G3PX.

Be sure to press the RESET button with power supplied to the G3PX.

The following wiring will be required if the breaker or contactor connected between the power supply and the G3PX is operated by the relay output of the G3PX.

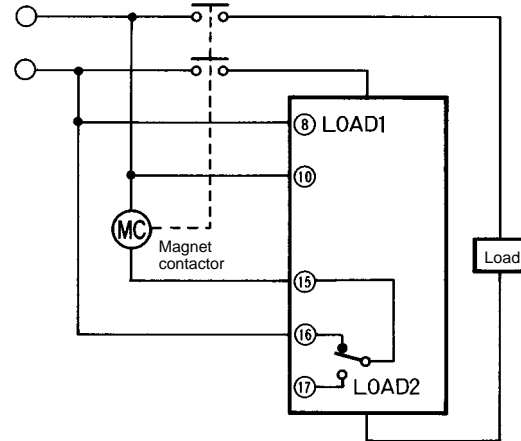

ALL DIMENSIONS SHOWN ARE IN MILLIMETERS.

To convert millimeters into inches, multiply by 0.03937. To convert grams into ounces, multiply by 0.03527.