





Ordering Information

■ Heads

Item	Setting distance	Detection range	Model
Red LED	 160±16 mm	40 × 32 mm	F10-S50R
	 100±10 mm	25 × 20 mm	F10-S30R
Green LED	 50±5 mm	12 × 10 mm	F10-S15R
Green LED	 33±1.5 mm	4.5 × 3.5 mm	F10-S05R

■ Amplifiers

Type	Output	No. of registered models	Model
Standard models	NPN	1	F10-C20
	PNP		F10-C25
Models with bank function	NPN	8 (one model per bank)	F10-C30
	PNP		F10-C35
Models with RS-232C and RS-422 interfaces	NPN		F10-C50
	PNP		F10-C55

■ Cables

Type	Model
RS-232C (cable length: 2 m)	F10-VR2
RS-422 (cable length: 2 m)	F10-VR4

Specifications

■ Ratings/Characteristics

Heads

Optical and Lighting System Specifications

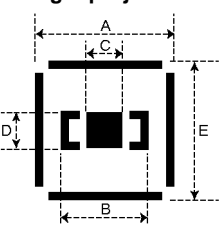
Item	Specifications			
	F10-S50R	F10-S30R	F10-S15R	F10-S05R
Setting distance	160±16 mm	100±10 mm	50±5 mm	33±1.5 mm
Detection range	40 mm × 32 mm	25 mm × 20 mm	12 mm × 10 mm	4.5 mm × 3.5 mm
Guide light projection size 	A: 40 mm B: 32 mm C: 13 mm D: 10 mm E: 32 mm (typ.)	A: 25 mm B: 20 mm C: 8 mm D: 6 mm E: 20 mm (typ.)	A: 12 mm B: 10 mm C: 4 mm D: 3 mm E: 10 mm (typ.)	A: 4.5 mm B: 3.5 mm C: 1.5 mm D: 1.0 mm E: 3.5 mm (typ.)
Built-in lens	Focus: f9.8 (fixed) Diaphragm: F2.8 (fixed)			Focus: f14.8 (fixed) Diaphragm: F3.5 (fixed)
Object lighting method	Pulse lighting (pulse width is synchronized with electronic shutter in operation)			
Object light source (emission wavelength)	8 red LEDs (680 nm)		8 green LEDs (540 nm)	
Main object color combination	Black and white, green and white, blue and white, and red and black		Black and white, red and white, green and white, blue and white, green and black, and blue and black	
Guide light projection source (emission wavelength)	1 green LED (540 nm)		1 blue LED (470 nm)	
Guide light projection method	Pulse lighting			

Camera Image Performance Specifications

Item	Specifications			
	F10-S50R	F10-S30R	F10-S15R	F10-S05R
Camera image element	1/5-inch CCD			
Shutter function	Electronic shutter at a speed range between 1/34722 s and 1/2894 s (automatically set during teaching)			

General Specifications

Item	Specification
Ambient temperature	Operating: 0°C to 40°C (with no icing or condensation) Storage: -25°C to 60°C (with no icing or condensation)
Ambient humidity	Operating: 35% to 85% (with no condensation) Storage: 35% to 85% (with no condensation)
Operating environment	With no corrosive gas
Input power supply	16.2 to 19.8 VDC (provided from amplifier)
Current consumption	150 mA max.
Insulation resistance	20 MΩ min. (at 500 VDC)
Dielectric strength	1,000 VAC at 50/60 Hz for 1 min
Degree of protection	IEC 60529 IP64
Vibration resistance (when using mounting bracket)	10 to 150 Hz, half-amplitude of 0.75 mm max. or 100 m/s ² max. for 32 min each in X, Y, and Z directions
Shock resistance (when using mounting bracket)	Peak acceleration: 300 m/s ² 3 times each in X, Y, and Z directions
Connection	Prewired (standard cable length: 2 m)
Casing material	Case: Aluminum die cast Front cover: Acrylic resin
Weight (when packed)	Approx. 400 g (Unit: approx. 300 g (including cable))
Accessories provided	Mounting bracket, 8 x M4 mounting screws, instruction manual

Amplifiers

Performance Specifications

Item	Specification	
Model	F10-C20/C30/C50	F10-C25/C35/C55
Output type	NPN	PNP
Measurement item	Pattern measurement/plain measurement	
Number of models	C20/C25: 1 model, C30/C35/C50/C55: 1 model per bank	
Bank selection	C20/C25: None, C30/C35/C50/C55: 8 banks	
Automatic teaching function	Yes	
Model size	Normal or wide mode (selectable)	
Measurement processing time	3.6 ms in normal mode and 10.8 ms in wide mode (continuous operation)	
Output signal (2 points)	Control output and enable output: NPN open collector with load voltage of 30 V max., load current of 50 mA max. and residual voltage of 1.2 V max.	Control output and enable output: PNP open collector with load voltage of 30 V max., load current of 50 mA max. and residual voltage of 2.0 V max.
Output selection	Matching output: ON when image matches the registered model. Not matching output: ON when image does not match the registered model.	
Input signal C20/C25 (4 points) C30/C35/C50/C55 (7 points)	External trigger input (with minimum pulse width of 1 ms), continuous measurement input, moving object teaching input, or stationary object teaching input Input is ON: Short-circuited to 0 V with short-circuit current of 1 mA max. or 1.5 V max. Input is OFF: Open or input voltage of 5 V min. (Max. input voltage: +26.4 VDC)	External trigger input (with minimum pulse width of 1 ms), continuous measurement input, moving object teaching input, or stationary object teaching input Input is ON: Short-circuited to Vcc or 9 V min. (Max. input voltage: +26.4 VDC) Input is OFF: Open or input voltage of 5 V max.
Head interface (1 channel)	Available Head: F10-S50R, F10-S30R, F10-S15R, or F10-S05R	
Indicators	Result indicator: 1 orange LED Level indicators: 8 green LEDs Threshold indicators: 7 red LEDs Status indicators: 3 on the C20/C25, or 7 on the C30/C35/C50/C55	
Operation interface	Teach/display button (TEACH/DISPLAY), UP/DOWN selection buttons, mode selector (TEACH/MON/RUN), 5 DIP switch pins: Automatic teaching (OFF/ON), model size (NORMAL/WIDE), OFF-delay timer (OFF/ON), matching/not matching (output ON for matching object/non-matching object), and external input (C50/C55 only) (LINE: To use the input line for external inputs in RUN mode; RS-232C/422: To use serial communications for external inputs in RUN mode)	

General Specifications

Item	Specification
Ambient temperature	Operating: 0°C to 50°C (with no icing or condensation) Storage: -25°C to 65°C (with no icing or condensation)
Ambient humidity	Operating: 35% to 85% (with no condensation) Storage: 35% to 85% (with no condensation)
Operating environment	With no corrosive gas
Input power supply	21.6 to 26.4 VDC (with ripple)
Current consumption	300 mA max.
Insulation resistance	20 MΩ min. (at 500 VDC)
Dielectric strength	1,000 VAC at 50/60 Hz for 1 min
Degree of protection	IEC 60529 IP40
Vibration resistance	10 Hz to 150 Hz, half-amplitude of 0.75 mm max. or 100 m/s ² max. for 32 min each in X, Y, and Z directions
Shock resistance	Peak acceleration: 300 m/s ² 3 times each in X, Y, and Z directions
Connection	Prewired (standard cable length: 2 m)
Casing material	ABS
Weight (when packed)	Approx. 300 g (Unit: approx. 200 g (including cable))
Accessories provided	Instruction manual

Engineering Data

■ Data Characteristics

F10-S50R

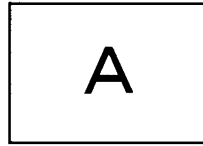
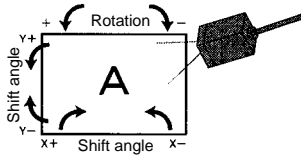

- The following data is obtained on the basis of sample sensing objects, each of which is as large as this size (A). (Typical example)
- The Head is inclined 15° to the sensing object.

Rotation Characteristics

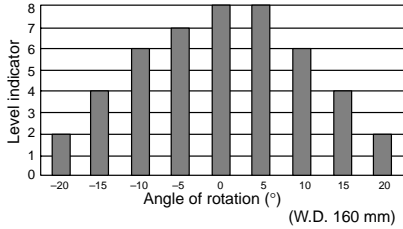

Area Position Characteristics (in X Direction)

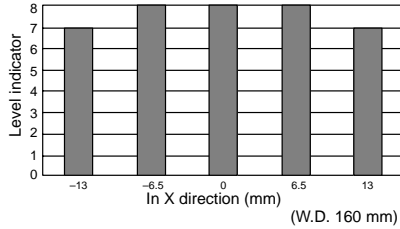

Area Position Characteristics (in Y Direction)

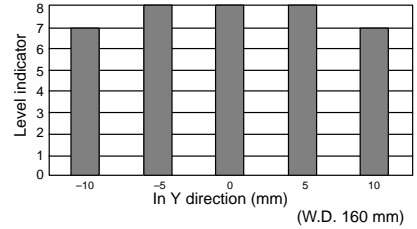

Shift Angle Characteristics (in X Direction)

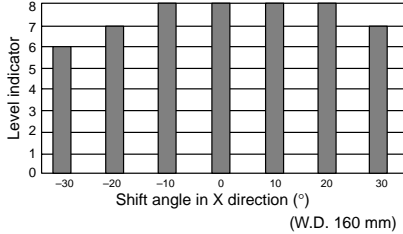

Shift Angle Characteristics (in Y Direction)

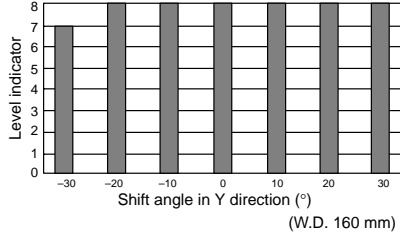

Distance Characteristics

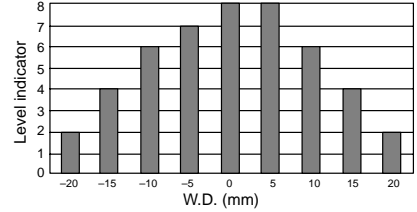

F10-S30R

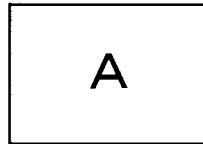
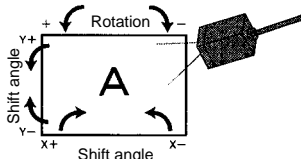

- The following data is obtained on the basis of sample sensing objects, each of which is as large as this size (A). (Typical example)
- The Head is inclined 15° to the sensing object.

Rotation Characteristics

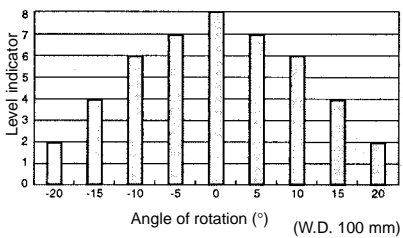

Area Position Characteristics (in X Direction)

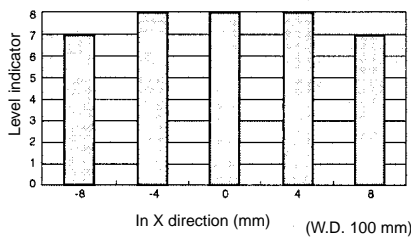

Area Position Characteristics (in Y Direction)

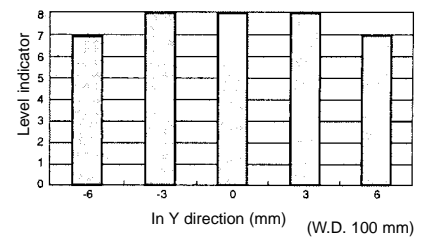

Distance Characteristics

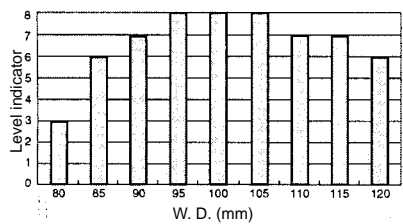

Shift Angle Characteristics (in X Direction)

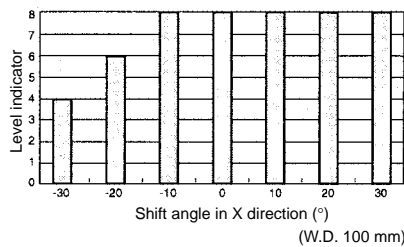

Shift Angle Characteristics (in Y Direction)

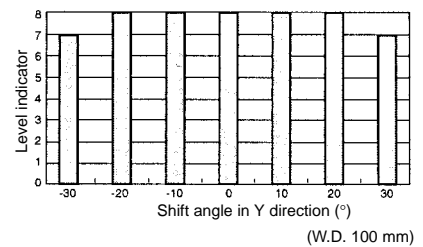

F10-S15R

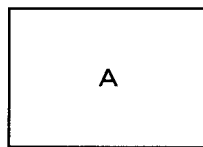
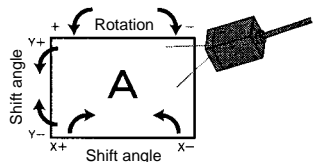

- The following data is obtained on the basis of sample sensing objects, each of which is as large as this size (A). (Typical example)
- The Head is inclined 15° to the sensing object.

Rotation Characteristics

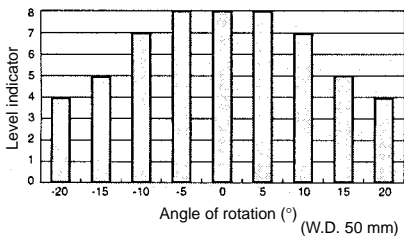

Area Position Characteristics (in X Direction)

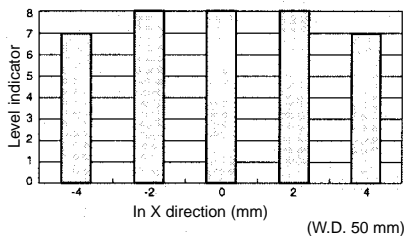

Area Position Characteristics (in Y Direction)

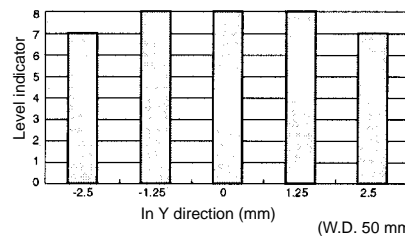

Distance Characteristics

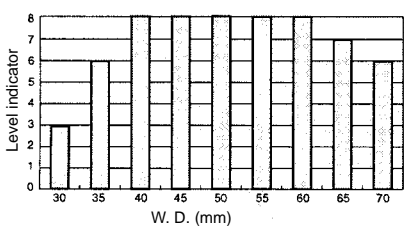

Shift Angle Characteristics (in X Direction)

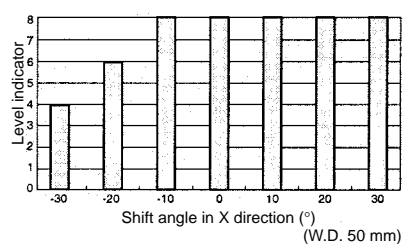

Shift Angle Characteristics (in Y Direction)

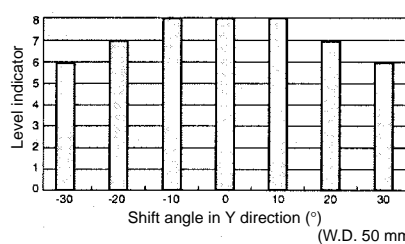

F10-S05R

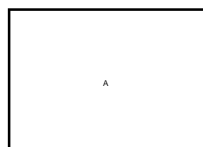
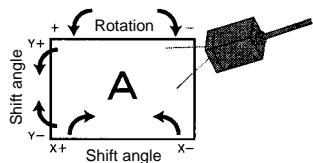

- The following data is obtained on the basis of sample sensing objects, each of which is as large as this size (A). (Typical example)
- The Head is inclined 15° to the sensing object.

Rotation Characteristics

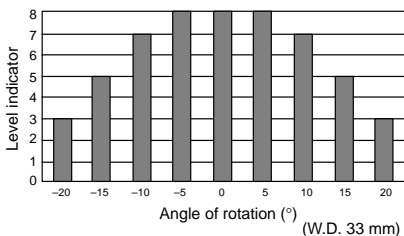

Area Position Characteristics (in X Direction)

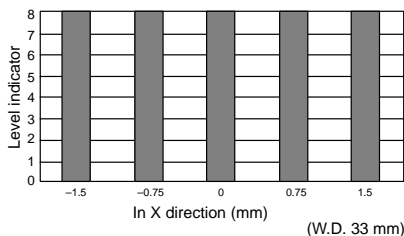

Area Position Characteristics (in Y Direction)

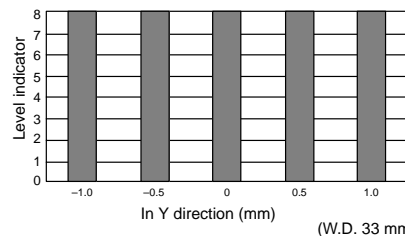

Distance Characteristics

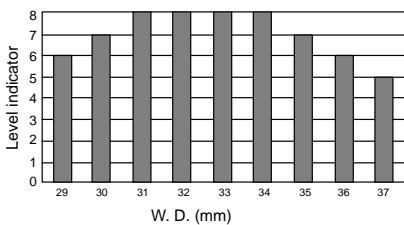

Shift Angle Characteristics (in X Direction)

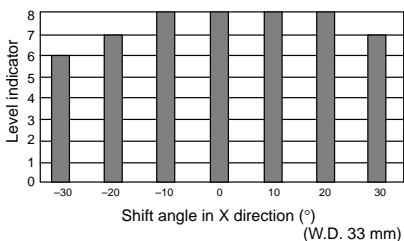

Shift Angle Characteristics (in Y Direction)

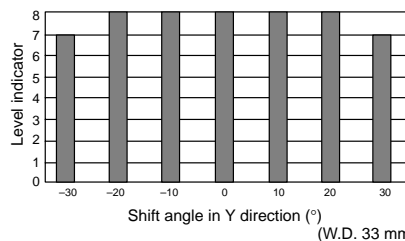

Nomenclature

Heads F10-S50R

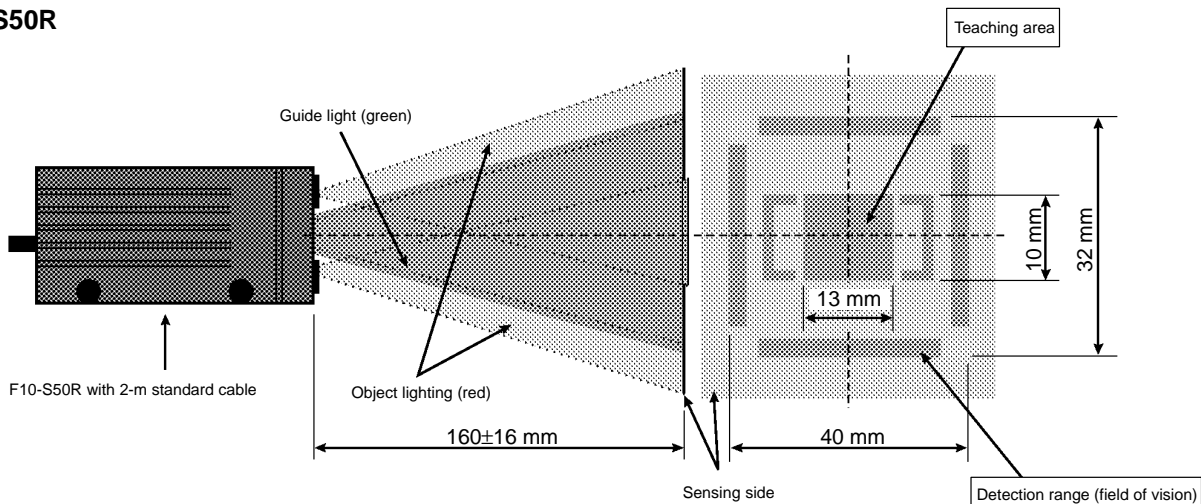

F10-S30R

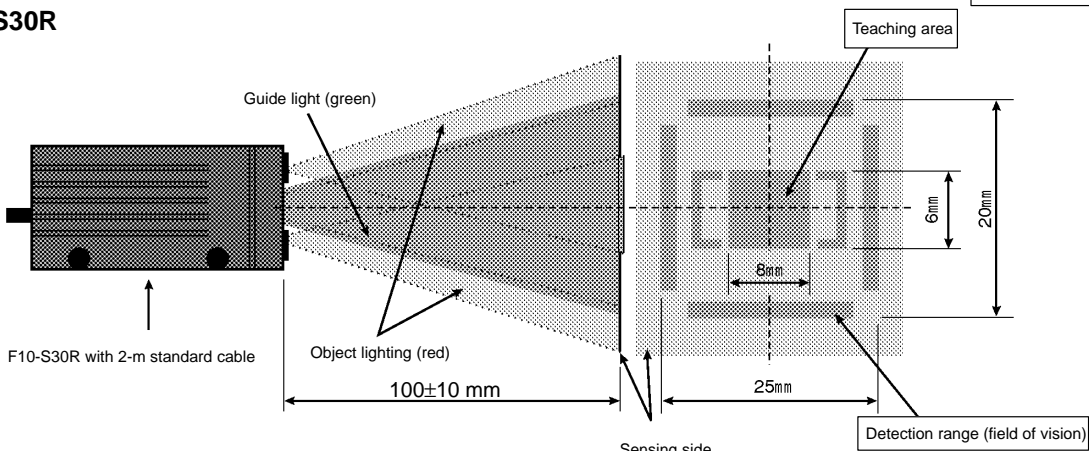

F10-S15R

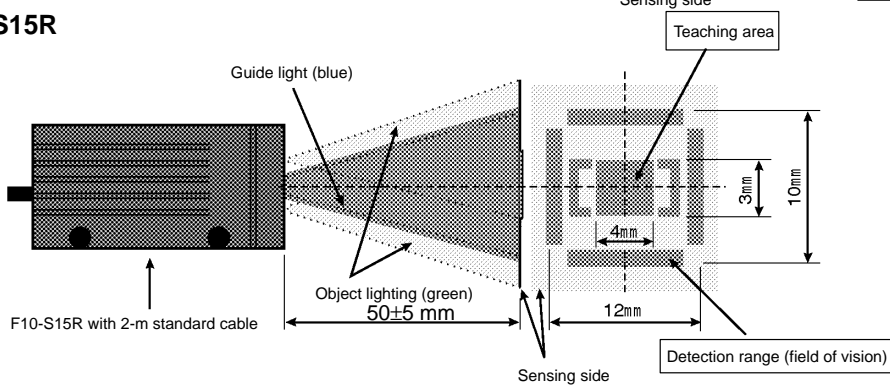

F10-S05R

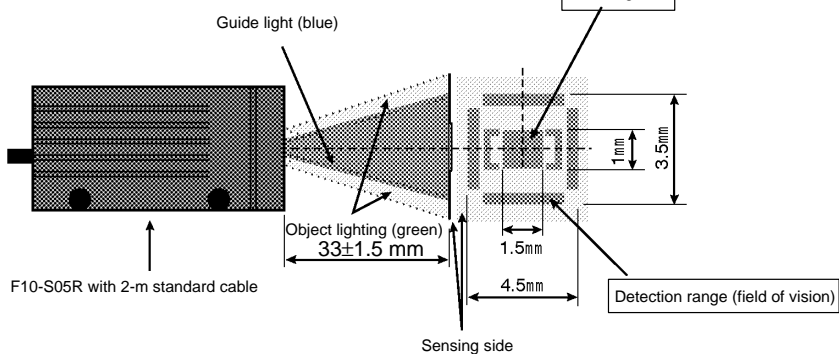

■ Amplifiers

F10-C20/C25

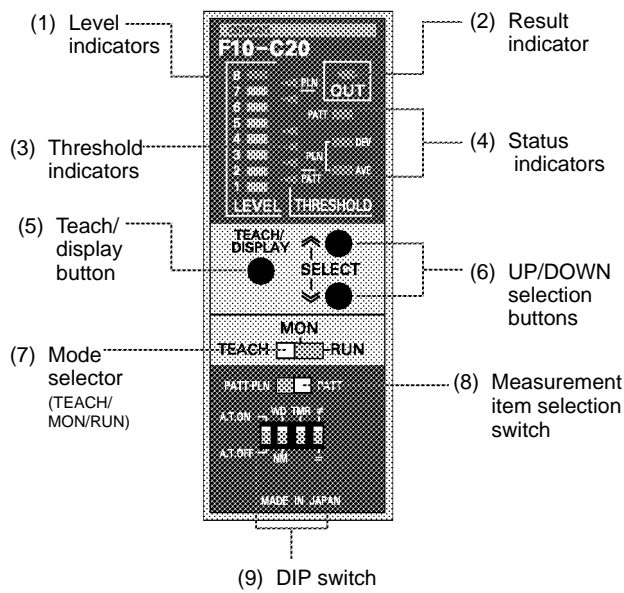

- (1) Displays measurement values (degree of conformity with the registered model).
- (2) ON: Lit
OFF: Not lit
- (3) Displays the threshold.
- (4) Displays type of value displayed on the level indicator.

F10-C20/C25

PATT (Pattern measurement): Degree of conformity with model
 PLN (Plain measurement) DEV: Deviation level
 AVE: Average density

F10-C30/C35/C50/C55

P: Pattern measurement: Degree of conformity model
 d: Plain measurement: Deviation level
 R: Plain measurement: Difference from average density

Also displays bank number for F10-C30/C35/C50/C55

- (5) Starts teaching.
Switches display item.
- (6) Changes the threshold value.
Changes measurement item selection level for plain measurement.
Changes bank number for F10-C30/C35/C50/C55.
- (7) TEACH: Teaching Mode
MON: Monitor Mode
RUN: Run Mode

F10-C30/C35/C50/C55

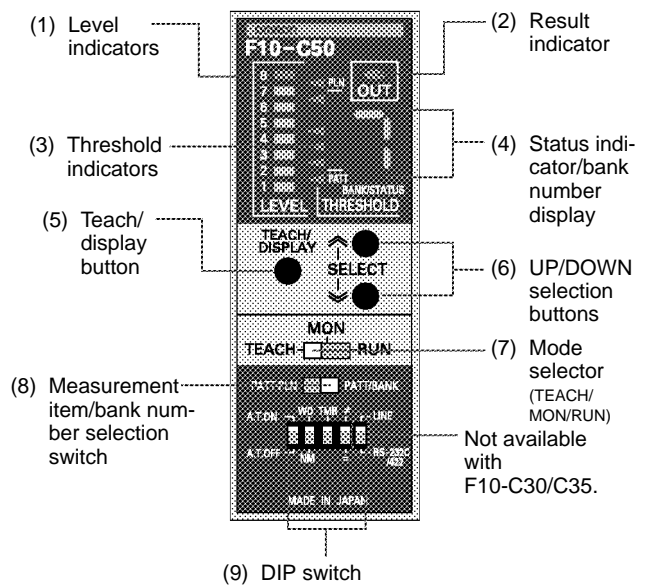

(8) • **Changing Measurement Items**

PATT•PLN PATT
 PATT/BANK Automatically switches between pattern measurement and plain measurement depending on the taught model.

PATT•PLN PATT
 PATT/BANK Executes pattern measurement only.

• **Bank Selection Mode**
 (F10-C30/C35/C50/C55)

PATT•PLN PATT/BANK Enters the mode for selecting and setting the bank in TEACH Mode.

Pattern Measurement
 Measures the degree with which the pattern and the detected image match to differentiate OK and NG images.

Plain Measurement
 Determines the deviation level and average density to differentiate OK and NG images.

	Plain	Color	Stain	Pattern
Teaching status (plain)	OK	NG	NG	NG

(9) DIP Switch

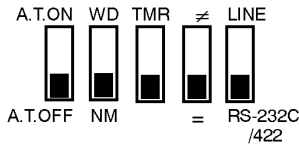

All the DIP switch pins are set to OFF at the factory.

Automatic Teaching

- A.T. ON: Teaching area automatically selected
- A.T. OFF: Teaching area fixed

A.T. ON

Automatically selects the pattern most suitable for the model. The part within the detection range where the deviation level between the background and the target is taken as the most suitable pattern for the model.

*If the pattern is at the very edge of, or slightly outside, the detection range, it may not be correctly taught. Make sure the pattern is as close as possible to the center of the detection range.

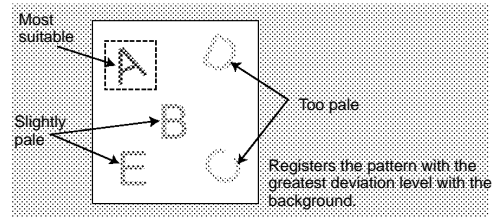

A.T. OFF

Registers only the pattern within the teaching area as the model.

Registers the pattern within the frame as the model.

Model Size

- WD: Wide mode
- NM: Normal mode

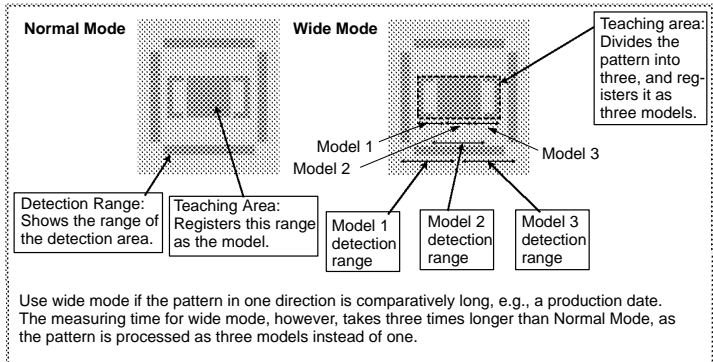

Use wide mode if the pattern in one direction is comparatively long, e.g., a production date. The measuring time for wide mode, however, takes three times longer than Normal Mode, as the pattern is processed as three models instead of one.

OFF Delay Timer

- TMR: Delays the output operation when the control output goes from ON to OFF (Default value is 40 ms. Refer to the *Operation Manual* for the Unit for changing procedure).
- No Marking: Timer OFF.

Matching/Not Matching

- Output ON when object does not match registered model.
- Output ON when object matches registered model.

External Input (F10-C50/C55 only)

- LINE: Executes external input in RUN mode via input line.
- RS-232C/422: Executes external input in RUN mode via serial communications.

Installation

■ Mounting Angle

- Incline the Head by 15° and mount the Head so that no regular reflection light affects the Sensor.
- Use the provided Mounting Bracket to mount the Head.

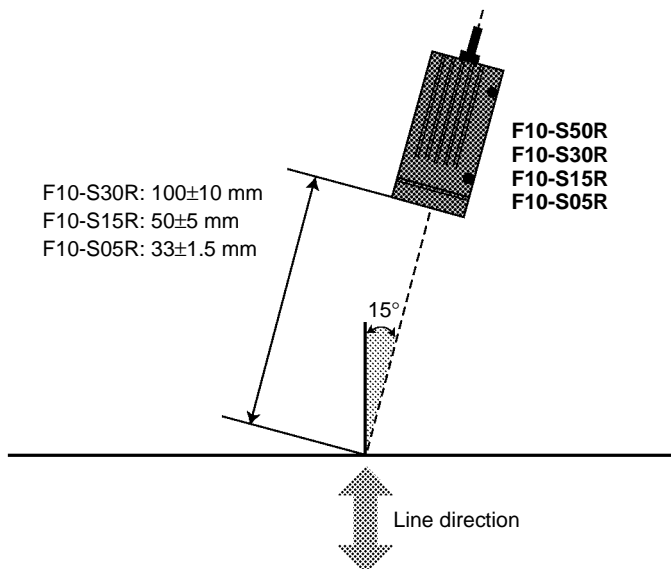

Simulation

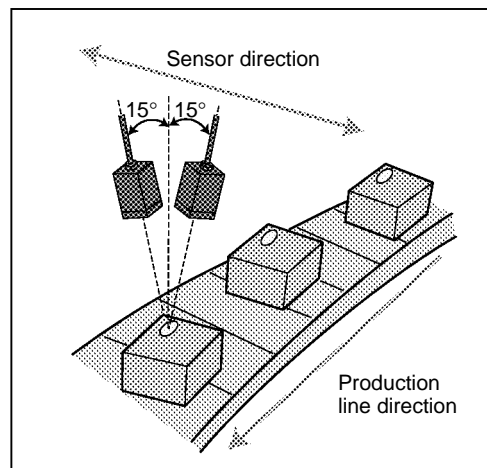

Note: Position the sensor perpendicular to the direction of motion of the target object.

■ Connection with Peripherals (F10-C50/C55 Only)

You can input the measurement trigger and output the measurement results via an RS-232C port. You can also back up the settings in an IBM PC/AT or compatible. Refer to the *Operation Manual* for the Unit for details on communications commands.

1:1 Connection

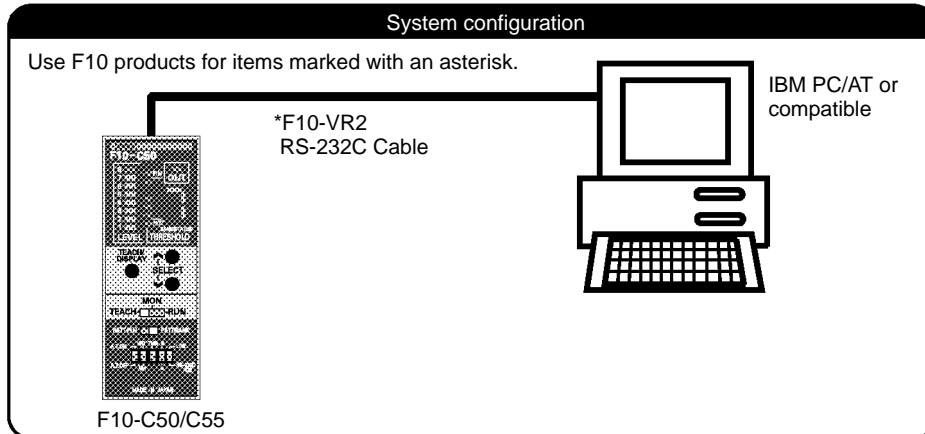

Multidrop Connections

A maximum of 31 F10-C50/C55 Sensors can communicate with an IBM PC/AT or compatible by connecting through RS-232C/422 converters.

Recommended Link Adapters (manufactured by OMRON)

Link Adapter: B500-AL004

Branching Link Adapter: B500-AL001

Note: When using a B500-AL004 Branching Link Adapter, be sure to enable terminating resistance and include a terminating resistance in the last link adapter according to the following:

Between RDA(-) and RDB(+): 220 Ω (1/2 W min.)

Between SDA(-) and SDB(+): 220 Ω (1/2 W min.)

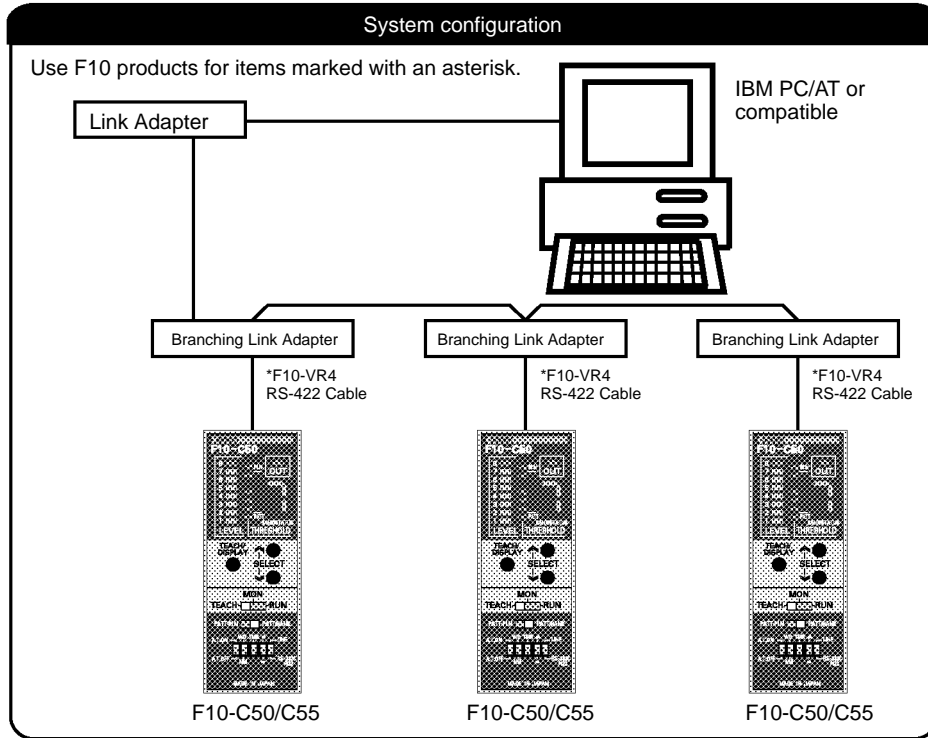

F10-VR2
RS-232C Cable: D-sub 9-pin connector (2 m)

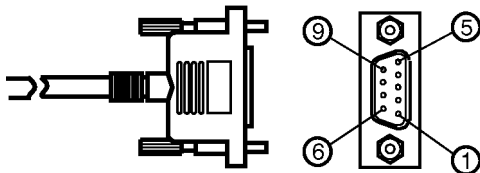

Pin No.	Signal	Name
2	SD (TXD)	Send data
3	RD (RXD)	Receive data
5	SG (GND)	Signal ground

F10-VR4
RS-422 Cable: D-sub 9-pin connector (2 m)

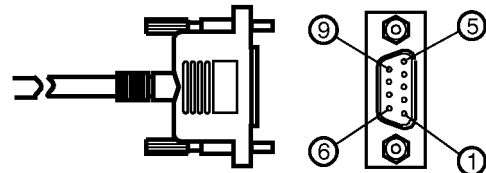

Pin No.	Signal	Name
1	RDB (+)	Receive data (+)
3	SG (GND)	Signal ground
5	SDB (+)	Send data (+)
6	RDA (-)	Receive data (-)
9	SDA (-)	Send data (-)

Note: 1. Signal and name are in reference to the F10.
2. Secure the connector with, for example, binding tape.

Operation

I/O Circuit Diagram

F10-C20 NPN Models

There are gray, green, and red input lines, but they are not used with this model. Take steps to ensure that these lines will not be short-circuited with other lines.

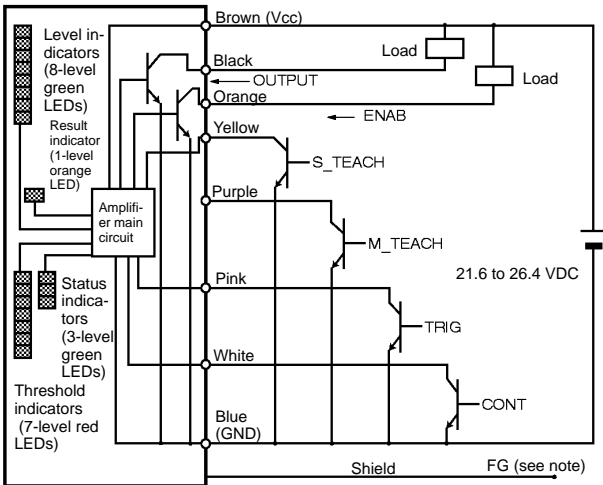

F10-C30/C50 NPN Models

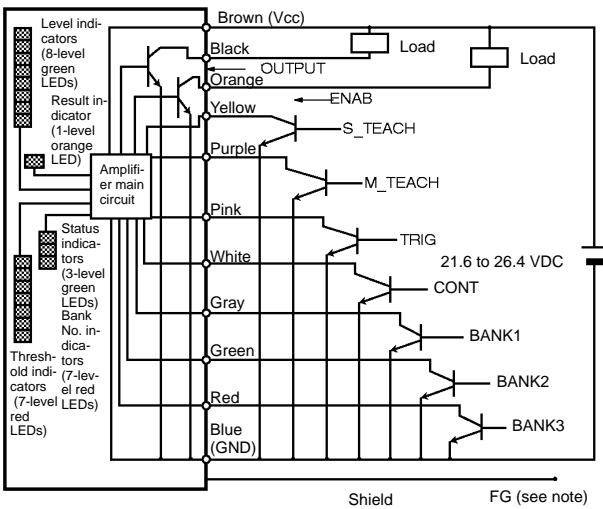

F10-C25 PNP Models

There are gray, green, and red input lines, but they are not used with this model. Take steps to ensure that these lines will not be short-circuited with other lines.

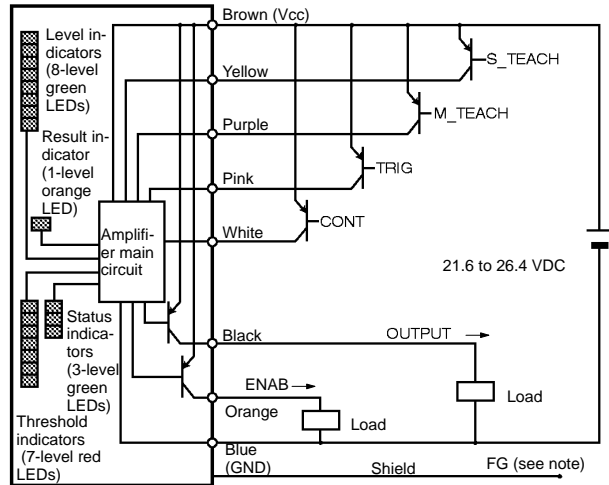

F10-C35/C55 PNP Models

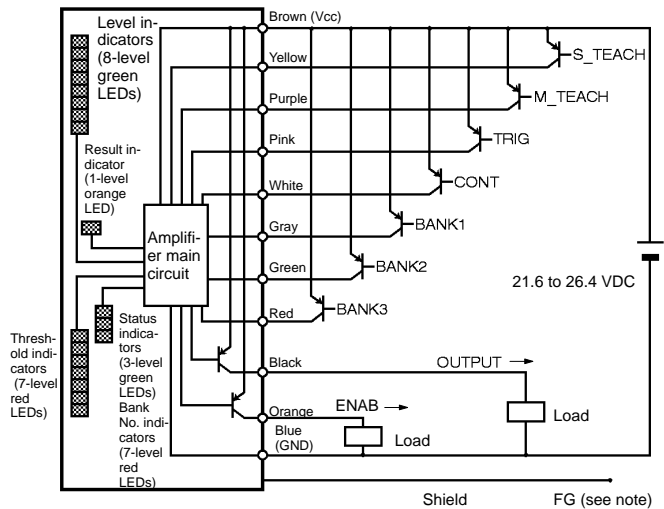

Note: For normal operation, ground or connect the shielded cable to 0 V. The shield is not connected to the interior or casing.

I/O Signals

Signal	Function
OUTPUT	Control output
ENAB	Enabled output
S_TEACH	Stationary object teaching input
M_TEACH	Moving object teaching input
TRIG	Measurement trigger input
CONT	Continuous measurement input
BANK1	Bank switching input (F10-C30/C35/C50/C55)
BANK2	
BANK3	

Switching Banks (F10-C30/C35/C50/C55)

You can switch banks by connecting BANK1 to BANK3 as shown below.

Bank No.	BANK1	BANK2	BANK3
Bank 0	OFF	OFF	OFF
Bank 1	ON	OFF	OFF
Bank 2	OFF	ON	OFF
Bank 3	ON	ON	OFF
Bank 4	OFF	OFF	ON
Bank 5	ON	OFF	ON
Bank 6	OFF	ON	ON
Bank 7	ON	ON	ON

- All input signals are enabled in RUN mode only.

■ Setting Procedure

1. Pattern Registration (TEACH Mode)

Use the following procedure to register measurement criteria.

- (1) Set the mode selector to TEACH.
- (2) Make the automatic teaching and model size settings on the DIP switch.
If using an F10-C30/C35/C50/C55, go to step (3) to set the bank number. If using an F10-C20/C25, go to step (5).
- (3) Set the measurement item/bank number selection switch to PATT/BANK. Bank No. 0 will be displayed.



POINT

Banks

Each F10-C30/C35/C50/C55 Sensor has eight banks for storing data, and a different threshold value can be stored in each of the eight banks. Use this function to take measurements under various conditions. You can switch operation simply by switching banks.

- (4) Press the UP/DOWN select buttons to set the bank number.
- (5) Use the measurement item (bank number) selection switch to set the measurement method.
- (6) Press the teach/display button after locating the sensing object in the detection range.

Measurement Items: PATT/BANK

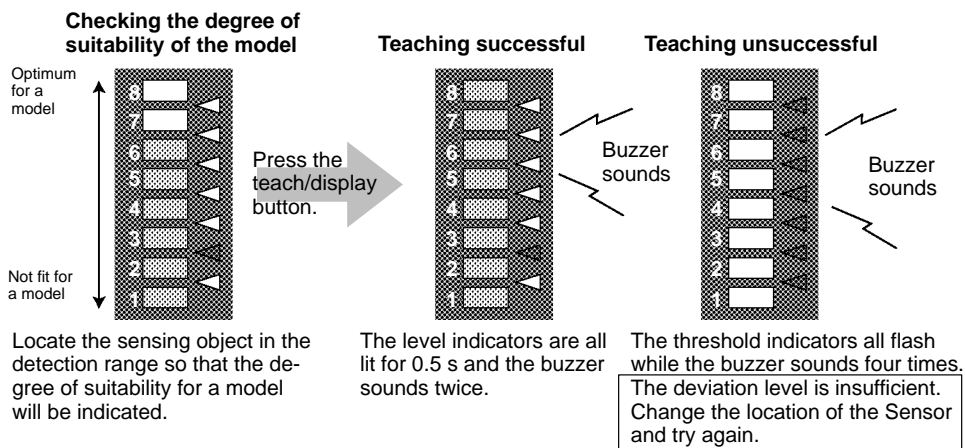

Measurement Item: PATT/PLN

Whether measurement is patterned or plain is determined automatically by comparing the contrast with the background within the detection range. When teaching is finished, all the level indicators will light for 0.5 s, and the buzzer will sound twice.

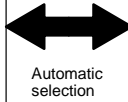
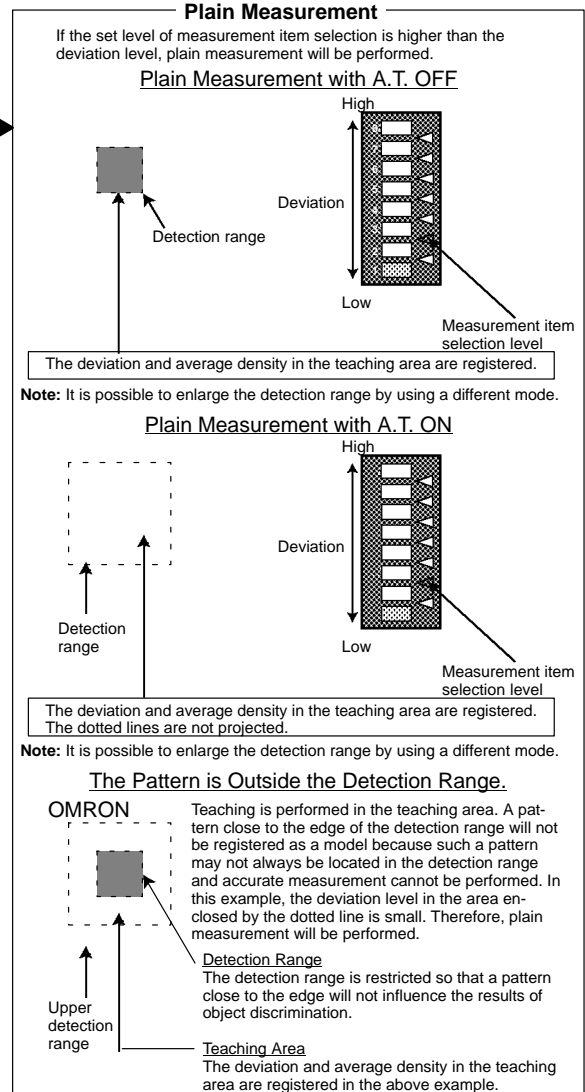
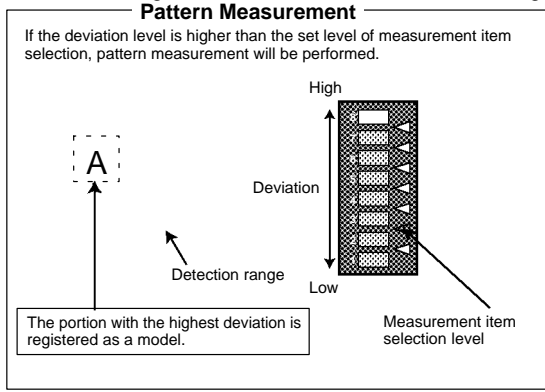

POINT

The set level of measurement item selection is increased or decreased by pressing the SELECT buttons. Adjust the level according to the background and deviation. The level is factory-set between 2 and 3.

If the object has some light-color lines or light-color patterns, pattern measurement may be performed. In this case, by increasing the set level of measurement item selection, plain measurement will be performed.

- Note:**
1. The detection range can be enlarged. Refer to the instruction sheet included with the device for details.
 2. Do not turn OFF the Sensor before the Sensor is set to MONITOR mode, otherwise the teaching data will be lost.

2. Threshold Adjustment/Sample Test (MONITOR Mode)

The Sensor operates in MONITOR mode for threshold level adjustments and desktop sample tests for object discrimination with no signal output. No external output operation signal or external input signal is accepted in MONITOR mode.

- (1) Set the mode selector to MON.

Measurement continues as long as the selector is set to MON.

Pattern Measurement

On the basis of the registered model, the level indicator indicates the degree of conformance of the sensing object.

- Status indicators, F10-C20/C25

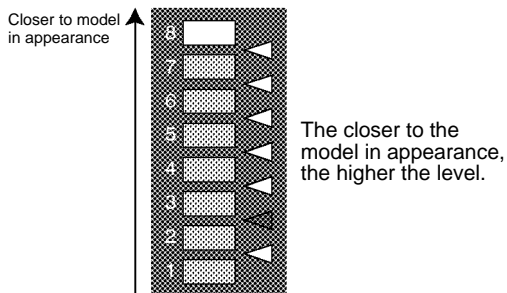
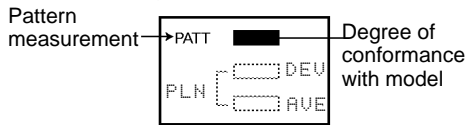

- Status indicator, F10-C30/C35/C50/C55

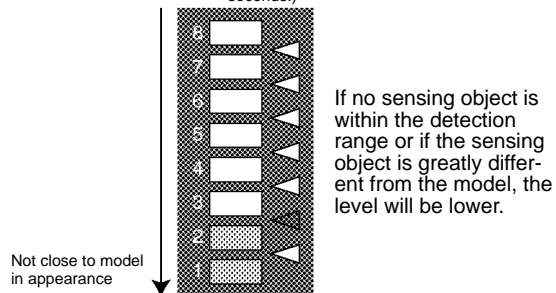
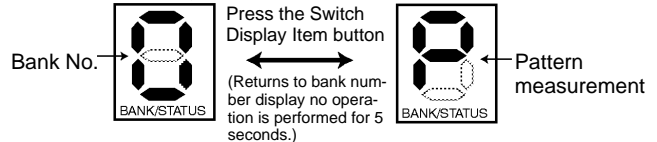

Plain Measurement

Press the teach/display button to change the display (DEV-AVE).

- Status indicators (F10-C20/C25)

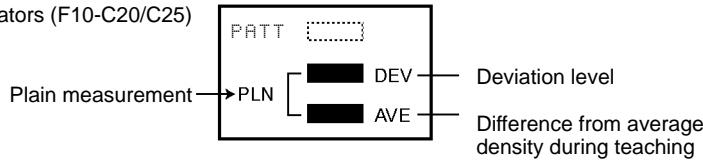

- Status indicator (F10-C30/C35/C50/C55)

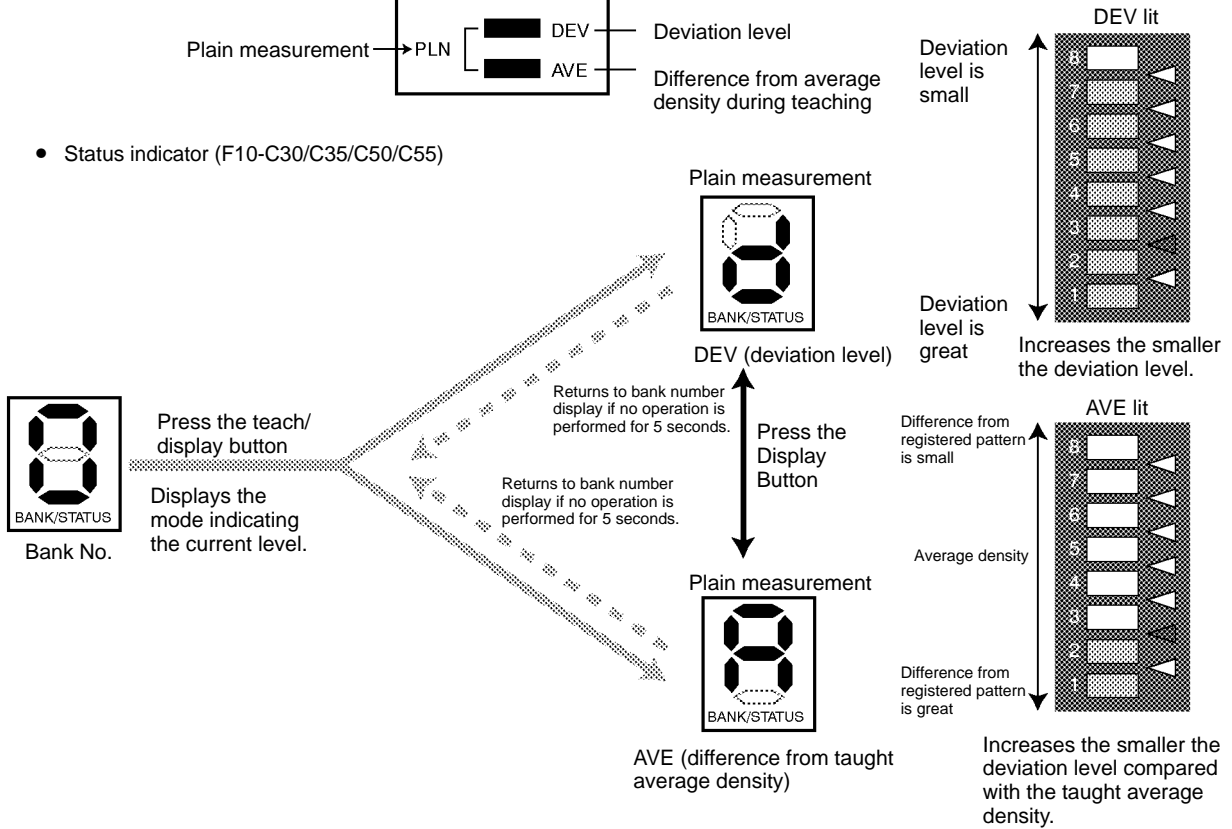

- (2) Press the UP/DOWN selection buttons to adjust the threshold.
 Adjust the threshold to the most suitable level by monitoring the level indicator.
 Altered threshold values will not be saved unless the mode selector is changed once to either RUN or TEACH.

Pattern Measurement

In wide mode, the pattern with the lowest degree of conformance among the three models is selected.

Plain Measurement

Set the threshold values for both DEV (deviation level) and AVE (average density). If either is lower than the threshold value, the discrimination result will be set to OFF.

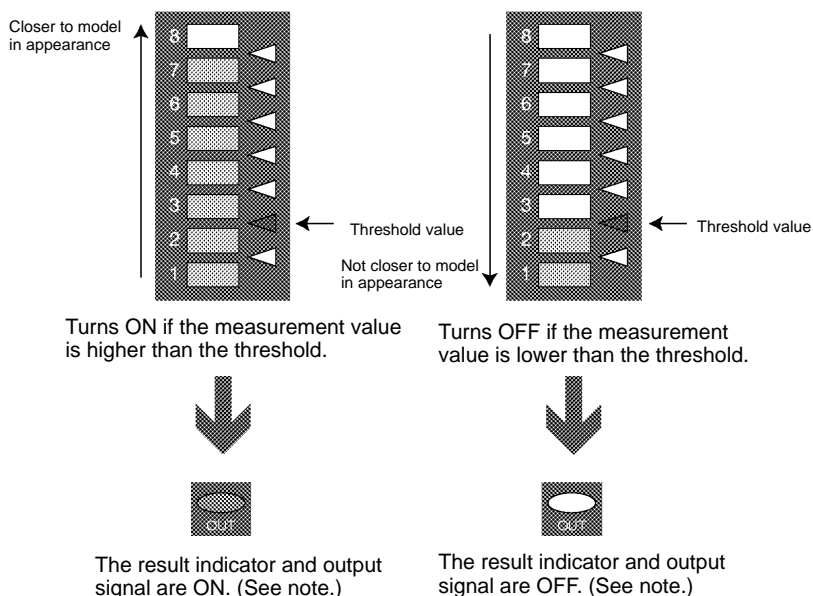

Note: Use the DIP switch to turn ON and OFF the output signal. Refer to *Nomenclature* for details.

3. Performing Measurement in Response to External Input Signals (RUN Mode)

- (1) Set the mode selector to RUN.

When the switch is set to RUN mode, measurements are made in response to external input signals.

Relationship between the F10 I/O terminal operations and ON/OFF indications in the timing charts are as shown in the following table.

Signal	Indication in timing charts	NPN (F10-C20/C30/C50)	PNP (F10-C25/C35/C55)
Input TRIG (pink) CONT (white) S_TEACH (yellow) M_TEACH (purple) BANK1 (gray) (see note) BANK2 (green) (see note) BANK3 (red) (see note)	ON	GND	Vcc
	OFF	OPEN	OPEN
Output OUTPUT (black) ENAB (orange)	ON	GND	Vcc
	OFF	Vcc	GND

Note: F10-C20/C25 do not have banks 1 to 3.

CONT Mode

In CONT mode, the Sensor is in sensing operation repeatedly while the CONT signal is ON. The measurement result is renewed once per measurement cycle, and output.

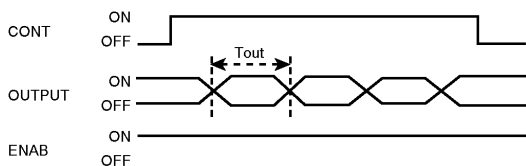

Measurement cycle: Tout

Normal mode: 3.6 ms
 Wide mode: 10.8 ms
 Plain measurement: 7.2 ms

TRIG Mode

The Sensor in TRIG mode is used for object measurement only once in synchronization with the rising edge of the TRIG signal and the result is output.

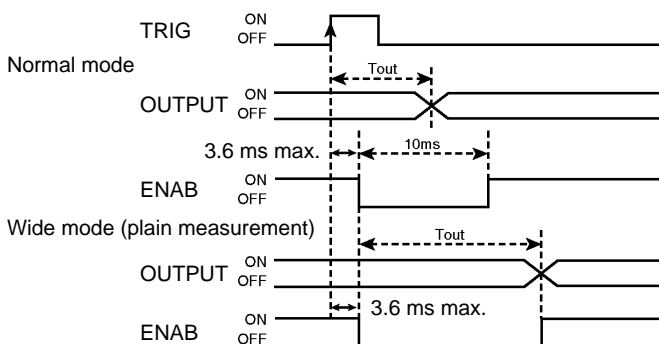

Minimum ON width for the trigger signal is 1 ms.

The OUTPUT signal is stored until the measurement results are refreshed.

ENAB signal:

OFF width is 10 ms in normal mode.

Turns ON when the OUTPUT signal is refreshed.

Measurement cycle: Tout

Normal mode: 7.2 ms max.
 Wide mode: 14.4 ms max.
 Plain measurement: 10.8 ms max.

POINT

Turning the Guide Light ON and OFF:

In RUN mode, even when synchronous measurement is not being executed, the guide light will normally be ON. It is possible to turn the guide light OFF (and ON again) by pressing the UP selection button as required.

While the guide light is being turned ON or OFF, the ENAB signal is turned OFF, and no external inputs can be received.

The OUTPUT signal is turned OFF when the UP selection button is pressed.

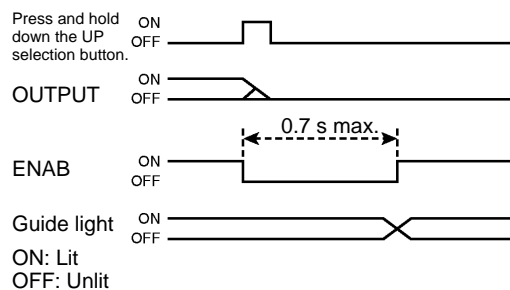

ON: Lit
 OFF: Unlit

External Teaching in RUN Mode

In RUN mode, a model can be registered by external signal input using either of the following methods.

Note: The data of the model is stored in the EEPROM when the teaching process of the Sensor completes. Therefore, do not turn OFF the Sensor during the teaching process.
If the Sensor is turned OFF, an EEPROM data error will result when the Sensor is turned ON again. In this case, perform proper teaching and threshold level adjustments again.

Stationary Object Teaching (S_TEACH)

Stationary object teaching is performed with the TRIG signal input or CONT signal input after external S_TEACH signal input. Therefore, do not move the object until teaching is completed.

- (1) Provide S_TEACH signal input.
- (2) Check that the ENAB signal is OFF.
- (3) Check that the stationary object is in the teaching area (or in the detection range if A.TEACH is set to ON).
- (4) Provide external CONT or TRIG signal input.
- (5) After teaching is completed, the ENAB signal will turn ON. At that time, check the status of the OUTPUT signal.
- (6) The OUTPUT signal will be ON if teaching is successfully completed.
- (7) The OUTPUT signal will be OFF if teaching is unsuccessful.
- (8) Turn the S_TEACH signal OFF to complete the teaching process. If teaching has been unsuccessful, the Sensor will remain in the previous status. Therefore, perform teaching again.

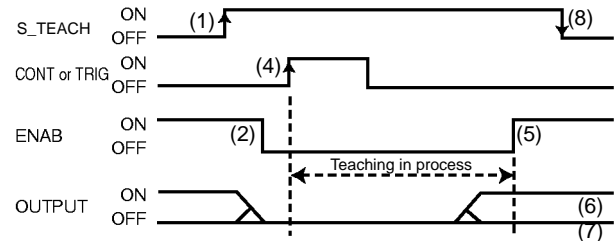

Moving Object Teaching (M_TEACH)

Moving object teaching is performed by using more than one object. Perform this teaching if the sensing objects cannot be stopped. After M_TEACH signal input, this teaching requires six processes in synchronization with external trigger input. The Sensor will not be in detection operation during the teaching process. External trigger input will be ignored after it is turned ON six times.

- (1) Provide external M_TEACH signal input.
- (2) Check that the ENAB signal is OFF.
- (3) Provide TRIG signal input in synchronization with the measurement timing of the sensing objects used for teaching.
- (4) Repeat step 3 six times.
- (5) After teaching is completed, the ENAB signal will turn ON. At that time, check the status of the OUTPUT signal.
- (6) The OUTPUT signal will be ON if teaching is successfully completed.
- (7) The OUTPUT signal will be OFF if teaching is unsuccessful.
- (8) Turn the M_TEACH signal OFF to complete the teaching process. If the teaching has been unsuccessful, the Sensor will remain in the previous status. Therefore, perform teaching again. The teaching operation will be disabled if the M_TEACH signal is turned OFF during the teaching process.

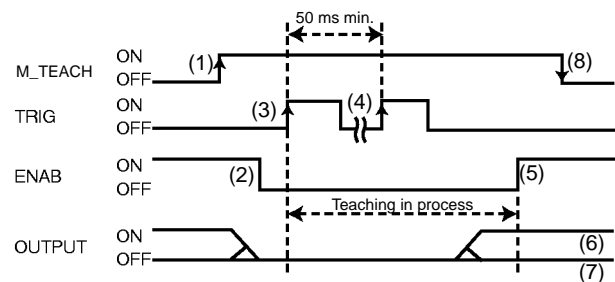

Enable Output

Enable output turns ON when the Sensor is ready to be in sensing operation. Therefore, enable output will turn OFF if the mode selector is set to TEACH or MON.

Enable output is OFF in the following cases in RUN mode.

1. The Sensor is in teaching process with external teaching input.
2. The Sensor is in sensing operation with TRIG signal input.
3. No teaching data has been registered.
4. The hardware fails.
5. The bank is being switched.
6. The guide light is being turned ON or OFF.

RS-232C/422 Command Inputs (F10-C50/C55 Only)

Communications with external devices, such as an IBM PC/AT or compatible, is possible via the RS-232/422 port. Refer to the *Operation Manual* for the unit for details on the communications commands.

Troubleshooting

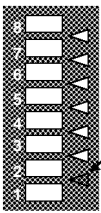
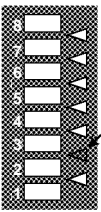
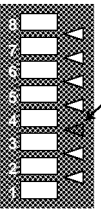
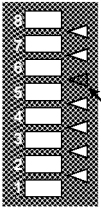
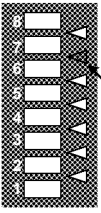
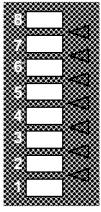
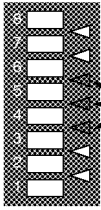
Problem	Probable cause	Remedy
 <p>Buzzer sounds</p> <p>This threshold indicator flashes and the buzzer sounds.</p>	<p>Head disconnection error</p> <p>The Head is not connected properly and no image signal is obtainable.</p>	<p>Connect the Head and turn the Sensor OFF and ON.</p> <p>Note: If the same error occurs again, the Head may be broken. Consult your OMRON representative.</p>
 <p>Buzzer sounds</p> <p>This threshold indicator flashes and the buzzer sounds.</p>	<p>Hardware error</p> <p>A hardware failure, such as CPU runaway, has resulted.</p>	<p>Consult your OMRON representative.</p>
 <p>Buzzer sounds</p> <p>This threshold indicator flashes and the buzzer sounds.</p>	<p>Head data read error</p> <ol style="list-style-type: none"> 1. The EEPROM data of the Head is not readable. 2. The data is illegal. 	
 <p>Buzzer sounds</p> <p>This threshold indicator flashes and the buzzer sounds.</p>	<p>Amplifier data read error</p> <ol style="list-style-type: none"> 1. The EEPROM data of the Amplifier is not readable. 2. The data is illegal. 	<p>Turn the Sensor OFF and ON.</p> <p>Note: All internal data of the Amplifier may be cleared.</p> <p>Note: If the same error occurs again after turning the Sensor OFF and ON, consult your OMRON representative.</p>
 <p>Buzzer sounds</p> <p>This threshold indicator flashes and the buzzer sounds.</p>	<p>Amplifier data write error</p> <ol style="list-style-type: none"> 1. No EEPROM data is written to the Amplifier. 2. The data is illegal. 	
 <p>Buzzer sounds</p> <p>All of the threshold indicators flash and the buzzer sounds three times.</p>	<p>Teaching data setting error</p> <p>The Sensor was set to MONITOR or RUN mode before teaching completed.</p>	<p>Perform the teaching of the Sensor in TEACH mode.</p> <p>➔ Refer to 1. <i>Pattern Registration (TEACH Mode)</i> on page 20.</p>
 <p>Buzzer sounds</p> <p>This threshold indicator flashes and the buzzer sounds.</p>	<p>Detection range mode error</p> <p>The detection range mode currently set is different from that set in teaching.</p>	<p>Perform teaching again in TEACH mode or change the detection range mode.</p>

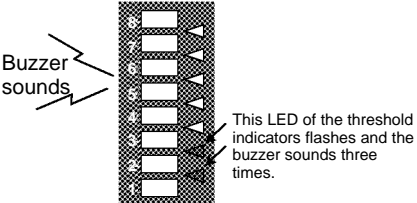
Problem	Probable cause	Remedy
	<p>Serial buffer overflow error</p> <p>Either the send buffer or receive buffer has become full during communications.</p>	<p>Send buffer overflow</p> <p>Change the communications settings.</p> <p>Receive buffer overflow</p> <p>Wait for a response from the F10, then send the command.</p>
<p>Control output (OUTPUT) and enable output are OFF, and will not turn ON.</p>	<p>A current exceeding the rated value has flowed to the output transistor and the overcurrent protective circuit has been triggered.</p>	<p>Reduce the current so that it will not exceed the rated value.</p> <p>Note: If the output does not turn ON even after reducing the current below the rated value, contact your OMRON representative.</p>

Dimensions

Note: All units are in millimeters unless otherwise indicated.

■ Amplifiers

F10-C□

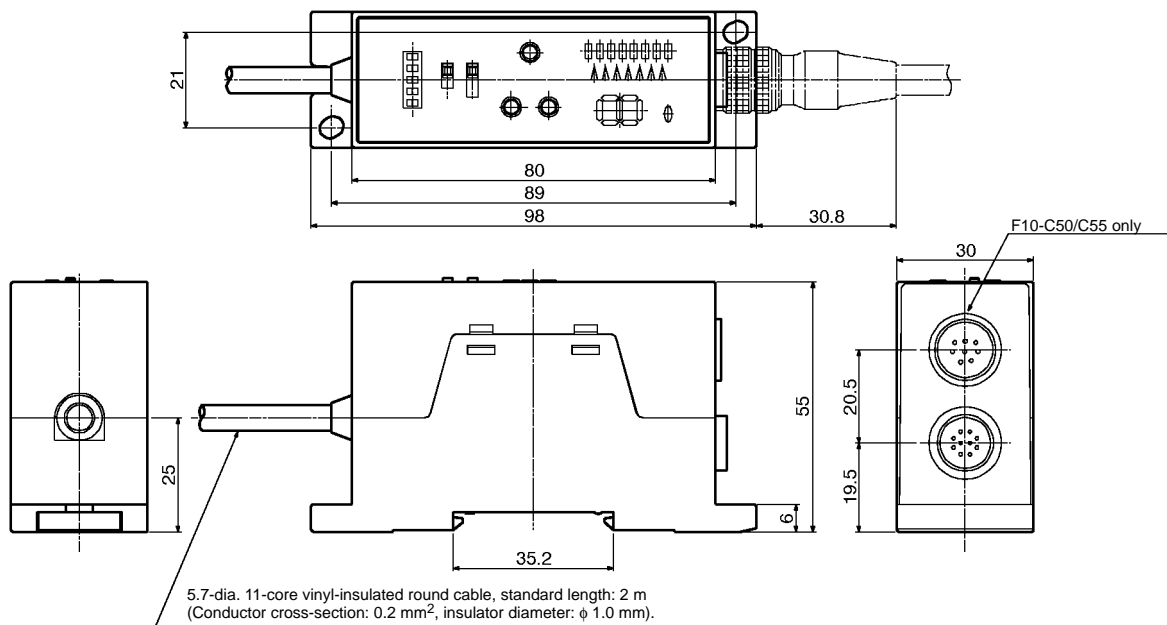

Mounting Dimensions

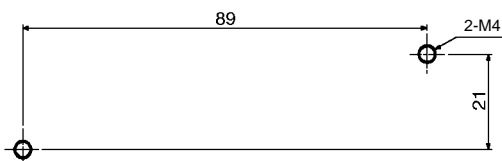

■ Heads

F10-S□R

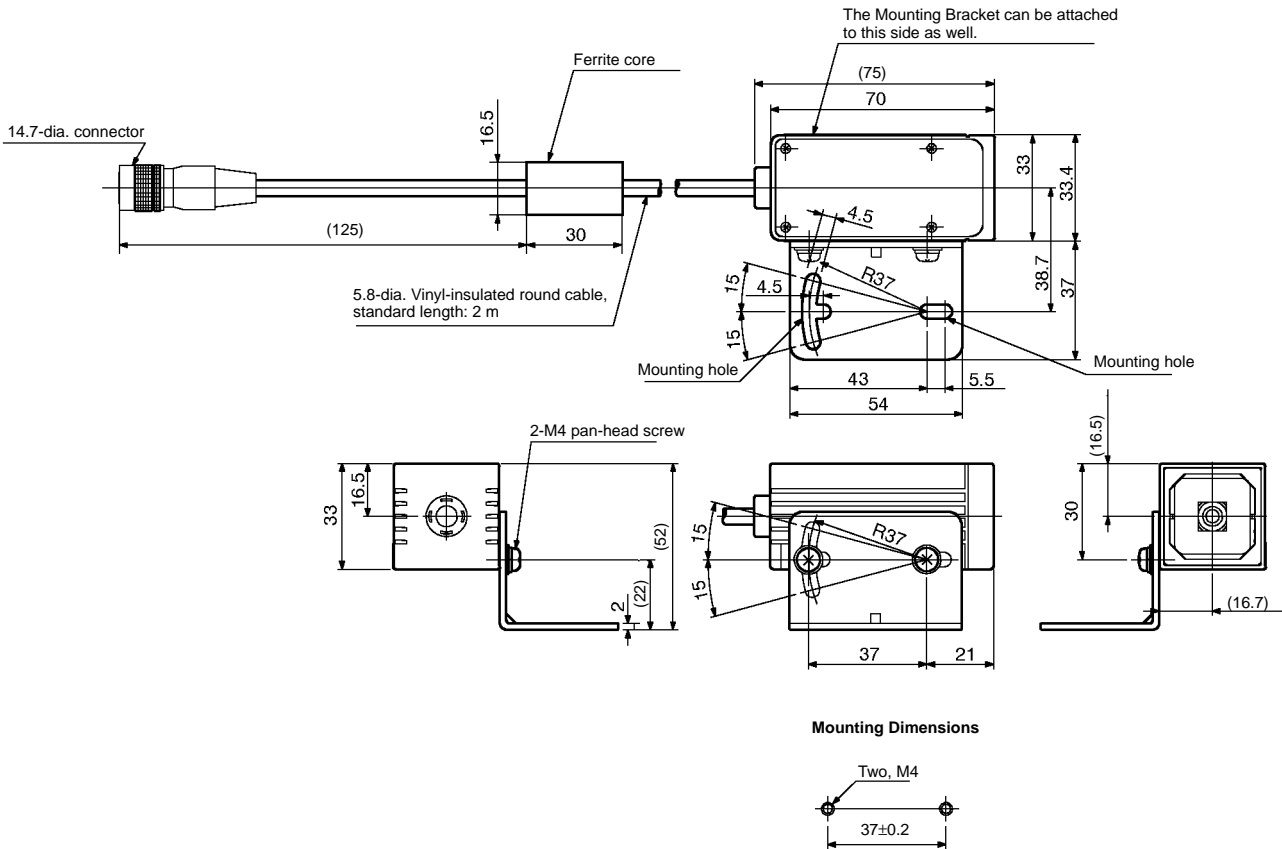

■ Mounting Bracket

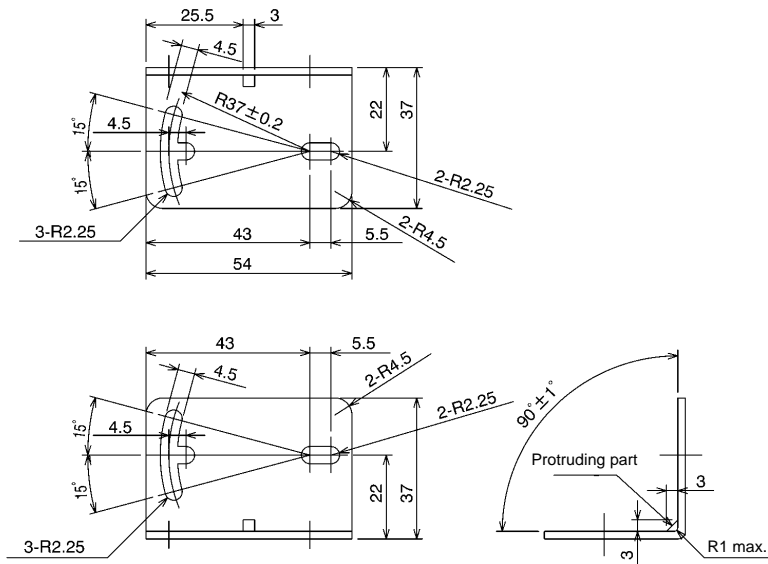

Precautions

Setup

The F10-C□ Amplifier radiates heat. If more than one Unit is installed side-by-side, make sure that there is a minimum space of 5 mm between adjacent Units as shown below.

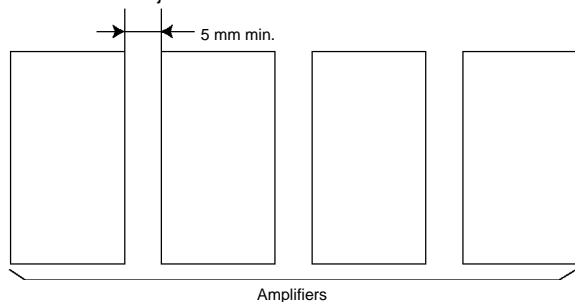

Do not disconnect or connect the Head while the Sensor is turned ON.

The F10-S30R/S50R cannot detect red objects with white backgrounds. Use the F10-S15R/S05R instead.

The F10-S15R/S05R cannot detect green objects with white backgrounds. Use the F10-S30R/S50R instead.

Make sure that the length of the cable of the Amplifier is no longer than 20 m.

Make sure that the tightening torque of each screw on the Head and Amplifier is no greater than 1.2 N • m.

The connector on the Amplifier and the metal screws on the bottom of the Amplifier are connected internally to 0-V terminal of the Amplifier.

The operating ambient temperature range of the Amplifier is between 0°C and 50°C under the following conditions.

1. Provide enough ventilation to the Amplifier. If more than one Unit is installed side-by-side, provide a ventilation fan for efficient ventilation.
2. Do not install the Amplifier close to heat-radiating devices such as heaters, transformers, and high-capacity resistors.
3. If power lines with high current for motors are wired close to the Amplifier, make sure that the Amplifier operates normally and take proper measures so that the power lines will not have a bad influence on the operation of the Amplifier.

Others

Application Precautions



Caution

Do not make mistakes in wiring, such as mistakes in polarity. Doing so may cause Sensor damage or malfunction.

Do not apply voltage exceeding the rated range. Doing so may cause Sensor damage or malfunction.

Do not short-circuit the load. Doing so may cause Sensor damage or malfunction.

Organic solvents may damage the casing of the Amplifier, which is made of ABS resin, and the transparent front panel of the Head, which is made of acrylic resin. Do not use paint thinner or any other organic solvent to clean the product.

Be sure to set the locking mechanism on the cables and units before use.

Do not use the Sensor in an environment where the degree of protection is not satisfied.

Do not disassemble the Sensor. Doing so may cause malfunction or breakdown.

General Precautions

The user must operate the product according to the performance specifications described in the brochure.

Before using the product under conditions which are not described in the brochure or applying the product to nuclear control systems, railroad systems, aviation systems, vehicles, combustion systems, medical equipment, amusement machines, safety equipment, and other systems, machines, and equipment that may have a serious influence on lives and property if used improperly, consult your OMRON representative.

The product has been produced at OMRON Ayabe which obtained ISO9001-approval for its quality system and ISO14001-approval for its environmental management system from international certification bodies.

ALL DIMENSIONS SHOWN ARE IN MILLIMETERS.

To convert millimeters into inches, multiply by 0.03937. To convert grams into ounces, multiply by 0.03527.

In the interest of product improvement, specifications are subject to change without notice.

OMRON Corporation

Industrial Automation Company

Advanced Sensors Group
Sensing Devices and Components Division H.Q.
Shiokoji Horikawa, Shimogyo-ku,
Kyoto, 600-8530 Japan
Tel: (81)75-344-7069/Fax: (81)75-344-7107

Regional Headquarters

OMRON EUROPE B.V.

Sensor Business Unit
Carl-Benz Str. 4, D-71154 Nufringen
Germany
Tel: (49)7032-811-0/Fax: (49)7032-811-199

OMRON ELECTRONICS LLC

1 East Commerce Drive, Schaumburg, IL 60173
U.S.A.

Tel: (1)847-843-7900/Fax: (1)847-843-8568

OMRON ASIA PACIFIC PTE. LTD.

83 Clemenceau Avenue,
#11-01, UE Square,
Singapore 239920
Tel: (65)835-3011/Fax: (65)835-2711

OMRON CHINA CO., LTD.

BEIJING OFFICE
Room 1028, Office Building,
Beijing Capital Times Square,
No. 88 West Chang'an Road,
Beijing, 100031 China
Tel: (86)10-8391-3005/Fax: (86)10-8391-3688

Authorized Distributor:

Cat. No. Q120-E1-2

Printed in Japan
0101-5M (0100)