

A Water-resistant Sensor with a Green Light Source Ideal for the Food and Packaging Industries

- The E3X-NVG uses a green light source to detect colors that cannot be detected using optical fiber photoelectric sensors with red light sources. (The E3X-NV incorporates a red light source.)
- Teaching without a workpiece is possible, greatly reducing sensor adjustment effort with no interruption of mark detection.
- Resists water.
- Remote teaching function for easy remote teaching from the controller.



Ordering Information

■ Amplifier Units

Item	Red light source	Green light source
Model	E3X-NV21	E3X-NVG21
Light source	Red LED (680 nm)	Green LED (565 nm)
Power supply voltage	12 to 24 VDC \pm 10%, ripple (p-p) 10% max.	
Current consumption	50 mA max.	
Response time	500 μ s max. at rated sensing distance	
Control output	NPN open collector, load current: 100 mA, residual voltage: 1 V max.	
Timer function (see note)	OFF-delay timer (fixed to 40 ms)	
Teaching confirmation function	Indicator (red/green LEDs) and buzzer	
Remote teaching input	Pink and blue wires are short-circuited when remote input is ON. Pink and blue wires are not short-circuited when remote input is OFF.	
Output	Light ON and Dark ON switch selectable	

Note: It is possible to disable the OFF-delay timer function by using the switch setting.





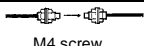
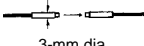
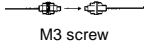
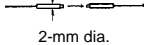
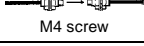
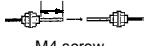
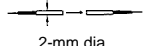
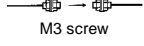
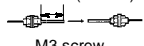
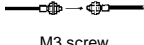
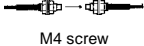
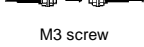
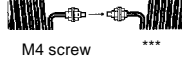
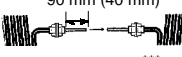

■ Fiber Unit

Through-beam (Separate) Sensors

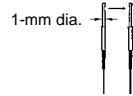
Model	Appearance	Sensing distance (standard object)* (NV: E3X-NV21; NVG: E3X-NVG21)	Min. sensing object (opaque objects)	Features
E32-T11L	 M4 screw	NV: 540 mm (1,280 mm**) (1.4-mm dia. min.) NVG: 40 mm (120 mm**) (1.4-mm dia. min.)	NV: 0.15-mm dia. NVG: 0.5-mm dia.	Long distance
E32-T12L	 3-mm dia.	NV: 540 mm (1.4-mm dia. min.) NVG: 40 mm (1.4-mm dia. min.)	NV: 0.15-mm dia. NVG: 0.5-mm dia.	Long distance
E32-T21L	 M3 screw	NV: 160 mm (0.9-mm dia. min.) NVG: 10 mm (0.9-mm dia. min.)	NV: 0.1-mm dia. NVG: 0.2-mm dia.	Long distance with thin fiber
E32-T22L	 2-mm dia.	NV: 160 mm (0.9-mm dia. min.) NVG: 10 mm (0.9-mm dia. min.)	NV: 0.1-mm dia. NVG: 0.2-mm dia.	Long distance with thin fiber
E32-TC200	 M4 screw	NV: 290 mm (2,100 mm**) (1-mm dia. min.) NVG: 28 mm (190 mm**) (1-mm dia. min.)	NV: 0.1-mm dia. NVG: 0.2-mm dia.	General-purpose
E32-TC200B E32-TC200B4	90 mm (40 mm)  M4 screw (): E32-TC200B4	NV: 290 mm (1-mm dia. min.) NVG: 28 mm (1-mm dia. min.)	NV: 0.1-mm dia. NVG: 0.2-mm dia.	General-purpose
E32-T22	 2-mm dia.	NV: 75 mm (0.5-mm dia. min.) NVG: 7 mm (0.5-mm dia. min.)	NV: 0.1-mm dia. NVG: 0.1-mm dia.	General-purpose
E32-TC200E	 M3 screw	NV: 75 mm (0.5-mm dia. min.) NVG: 8 mm (0.5-mm dia. min.)	NV: 0.1-mm dia. NVG: 0.1-mm dia.	General-purpose
E32-TC200F E32-TC200F4	90 mm (40 mm)  M3 screw (): E32-TC200F4	NV: 75 mm (0.5-mm dia. min.) NVG: 8 mm (0.5-mm dia. min.)	NV: 0.1-mm dia. NVG: 0.1-mm dia.	General-purpose
E32-TC200A	 M3 screw	NV: 270 mm (1-mm dia. min.) NVG: 28 mm (1-mm dia. min.)	NV: 0.1-mm dia. NVG: 0.2-mm dia.	General-purpose
E32-T11	 M4 screw	NV: 260 mm (1,400 mm**) (1-mm dia. min.) NVG: 10 mm (120 mm**) (1-mm dia. min.)	NV: 0.1-mm dia. NVG: 0.2-mm dia.	Flexible (resists breaking)
E32-T21	 M3 screw	NV: 70 mm (0.5-mm dia. min.) NVG: 6 mm (0.5-mm dia. min.)	NV: 0.1-mm dia. NVG: 0.1-mm dia.	Flexible (resists breaking)
E32-TC200C	 M4 screw ***	NV: 210 mm (850 mm**) (1-mm dia. min.) NVG: 18 mm (100 mm**) (1-mm dia. min.)	NV: 0.1-mm dia. NVG: 0.2-mm dia.	Flexible spiral cord
E32-TC200D E32-TC200D4	90 mm (40 mm)  M4 screw *** (): E32-TC200D4	NV: 210 mm (1-mm dia. min.) NVG: 18 mm (1-mm dia. min.)	NV: 0.1-mm dia. NVG: 0.2-mm dia.	Flexible spiral cord

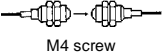
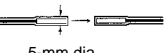
*Standard object: opaque; **With the E39-F1.; ***Cannot be trimmed;

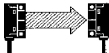
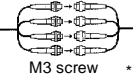
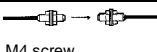
****Teflon is a registered trademark of the Dupont Company and the Mitsui Dupont Chemical Company for their fluoride resin.

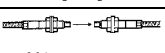
Model	Appearance	Sensing distance (standard object)* (NV: E3X-NV21; NVG: E3X-NVG21)	Min. sensing object (opaque objects)	Features
E32-T14L	 3-mm dia.	NV: 140 mm (1-mm dia. min.) NVG: 10 mm (1-mm dia. min.)	NV: 0.2-mm dia. NVG: 0.1-mm dia.	Side-view; long distance
E32-T24	 1-mm dia.	NV: 48 mm (0.5-mm dia. min.) NVG: 2 mm (0.5-mm dia. min.)	NV: 0.1-mm dia. NVG: 0.2-mm dia.	Side-view; space saving
E32-T14		NV: 1,070 mm (4-mm dia. min.) NVG: 80 mm (4-mm dia. min.)	NV: 0.2-mm dia. NVG: 0.2-mm dia.	Side-view
E32-T17L	 M4 screw	NV: 7,500 mm (10-mm dia. min.) NVG: 800 mm (10-mm dia. min.)	NV: 0.5-mm dia. NVG: 2.1-mm dia.	Long distance
E32-T12F	 5-mm dia.	NV: 1,070 mm (4-mm dia. min.) NVG: 70 mm (4-mm dia. min.)	NV: 0.3-mm dia. NVG: 0.6-mm dia.	Teflon-covered****; withstands chemicals and harsh environments
E32-T14F	 5-mm dia.	NT: 110 mm (3-mm dia. min.) NM: 100 mm (3-mm dia. min.)	NT: 0.3-mm dia. NM: 0.3-mm dia.	Teflon covered****; side-view; withstands chemicals and harsh environments
E32-T16		NV: 1,070 mm (visual field: 2 x 10 mm)***** (10-mm dia. min.) NVG: 150 mm (visual field: 2 x 10 mm) (10-mm dia. min.)	NV: 5-mm dia. (0.15-mm dia.)***** NVG: 7-mm dia. (1.0-mm dia.)*****	Screened; detects over a 10-mm area
E32-M21	 M3 screw ***	NV: 210 mm (2-mm dia. min.) NVG: 20 mm (2-mm dia. min.)	NV: 0.1-mm dia. NVG: 0.3-mm dia.	4-head; 4-point detection
E32-T51	 M4 screw	NV: 320 mm (1.5-mm dia. min.) NVG: 20 mm (1.5-mm dia. min.)	NV: 0.3-mm dia. NVG: 1.0-mm dia.	Heat-resistant; resists 150°C
E32-T54	 2-mm dia.	NT: 85 mm (1-mm dia. min.) NM: 70 mm (1-mm dia. min.)	NT: 0.4-mm dia. NM: 0.4-mm dia.	Heat-resistant; side-view; resists 150°C
E32-T61	 M4 screw ***	NV: 190 mm (2,100 mm**) (1-mm dia. min.) NVG: 18 mm (130 mm**) (1-mm dia. min.)	NV: 0.15-mm dia. NVG: 0.5-mm dia.	Heat-resistant; resists 300°C

*Standard object: opaque; **With the E39-F1.; ***Cannot be trimmed;

****Teflon is a registered trademark of the Dupont Company and the Mitsui Dupont Chemical Company for their fluoride resin.

*****Sensing distances for slit applications are in the following table.





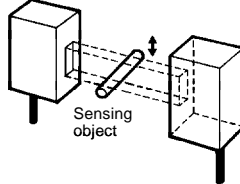













***** The minimum size of the sensing object varies with the sensing method.
Values not in parentheses are possible within a 10-mm sensing distance.

E32-T16 with Slits







Slit width		0.5-mm	1.0-mm	Sensing method
With E3X-NV21	Sensing distance	480 mm	850 mm	
	Min. sensing object	5.0-mm dia. (0.1-mm dia.)*	5.0-mm dia. (0.1-mm dia.)*	
With E3X-NVG21	Sensing distance	20 mm	60 mm	
	Min. sensing object	7.0-mm dia. (0.25-mm dia.)*	7.0-mm dia. (0.35-mm dia.)*	

* Values without parentheses are possible within a 10-mm sensing area.
Values in parentheses are possible at the center of a 10-mm sensing area.

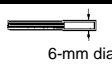
Reflective Sensors

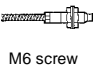
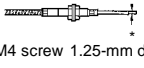
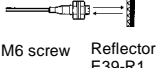
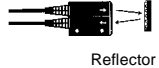
Model	Appearance	Sensing distance (standard object) (NV: E3X-NV21; NVG: E3X-NVG21)		Min. sensing object (copper wire)	Features
		White paper	Black paper		
E32-D11L	 M6 screw	NV: 160 mm (20 x 20 cm) NVG: 10 mm (2.5 x 2.5 cm)	NV: 44 mm (20 x 20 cm) NVG: ---	NV: 0.012-mm dia. NVG: 3.0-mm dia.	Long distance
E32-D12	 3-mm dia.	NV: 85 mm (10 x 10 cm) NVG: 2 mm (2.5 x 2.5 cm)	NV: 22 mm (10 x 10 cm) NVG: ---	NV: 0.012-mm dia. NVG: 1.6-mm dia.	Long distance
E32-D21L	 M4 screw	NV: 38 mm (5 x 5 cm) NVG: 1 mm (2.5 x 2.5 cm)	NV: 10 mm (5 x 5 cm) NVG: ---	NV: 0.012-mm dia. NVG: 1.0-mm dia.	Long distance
E32-D22L	 3-mm dia.	NV: 38 mm (5 x 5 cm) NVG: 1 mm (2.5 x 2.5 cm)	NV: 10 mm (5 x 5 cm) NVG: ---	NV: 0.012-mm dia. NVG: 1.0-mm dia.	Long distance
E32-DC200	 M6 screw	NV: 110 mm (10 x 10 cm) NVG: 10 mm (2.5 x 2.5 cm)	NV: 22 mm (10 x 10 cm) NVG: ---	NV: 0.012-mm dia. NVG: 0.2-mm dia.	General-purpose
E32-DC200B E32-DC200B4	 90 mm (40 mm) M6 screw (): E32-DC200B4	NV: 110 mm (10 x 10 cm) NVG: 10 mm (2.5 x 2.5 cm)	NV: 22 mm (10 x 10 cm) NVG: ---	NV: 0.012-mm dia. NVG: 1.0-mm dia.	General-purpose
E32-DC200E	 M3 screw	NV: 22 mm (2.5 x 2.5 cm) NVG: 2 mm (2.5 x 2.5 cm)	NV: 5 mm (2.5 x 2.5 cm) NVG: ---	NV: 0.012-mm dia. NVG: 1.0-mm dia.	General-purpose
E32-DC200F E32-DC200F4	 90 mm (40 mm) M3 screw (): E32-DC200F4	NV: 22 mm (2.5 x 2.5 cm) NVG: 2 mm (2.5 x 2.5 cm)	NV: 5 mm (2.5 x 2.5 cm) NVG: ---	NV: 0.012-mm dia. NVG: 1.0-mm dia.	General-purpose
E32-D11	 M6 screw	NV: 65 mm (10 x 10 cm) NVG: 7 mm (2.5 x 2.5 cm)	NV: 14 mm (10 x 10 cm) NVG: ---	NV: 0.012-mm dia. NVG: 0.5-mm dia.	Flexible (resists breaking)
E32-D21	 M3 screw	NV: 9 mm (2.5 x 2.5 cm) NVG: 1 mm (2.5 x 2.5 cm)	NV: 1.7 mm (2.5 x 2.5 cm) NVG: ---	NV: 0.012-mm dia. NVG: 1.0-mm dia.	Flexible (resists breaking)
E32-DC200C	 M6 screw	NV: 33 mm (5 x 5 cm) NVG: 2.5 mm (2.5 x 2.5 cm)	NV: 6.5 mm (5 x 5 cm) NVG: ---	NV: 0.012-mm dia. NVG: 1.0-mm dia.	Flexible spiral cord
E32-DC200D E32-DC200D4	 90 mm (40 mm) M6 screw (): E32-DC200D4	NV: 33 mm (5 x 5 cm) NVG: 2.5 mm (2.5 x 2.5 cm)	NV: 6.5 mm (5 x 5 cm) NVG: ---	NV: 0.012-mm dia. NVG: 1.0-mm dia.	Flexible spiral cord
E32-DC9G E32-DC9G4	 90 mm (40 mm) 1.2-mm dia. (): E32-DC9G4	NV: 38 mm (5 x 5 cm) NVG: 2.5 mm (2.5 x 2.5 cm)	NV: 7.5 mm (5 x 5 cm) NVG: ---	NV: 0.012-mm dia. NVG: 1.0-mm dia.	Stainless steel sleeve
E32-D33	 3-mm dia. 0.8-mm dia.	NV: 7 mm (2.5 x 2.5 cm) NVG: ---	NV: 1.4 mm (2.5 x 2.5 cm) NVG: ---	NV: 0.012-mm dia. NVG: ---	Super-thin; minute object detection
E32-CC200	 M6 screw	NV: 110 mm (10 x 10 cm) NVG: 10 mm (2.5 x 2.5 cm)	NV: 22 mm (10 x 10 cm) NVG: 2 mm (2.5 x 2.5 cm)	NV: 0.012-mm dia. NVG: 0.5-mm dia.	Coaxial; positioning accuracy
E32-D32	 2-mm dia.	NV: 33 mm (2.5 x 2.5 cm) NVG: 2.5 mm (2.5 x 2.5 cm)	NV: 5.8 mm (2.5 x 2.5 cm) NVG: ---	NV: 0.012-mm dia. NVG: 0.5-mm dia.	General-purpose
E32-D32L	 3-mm dia.	NV: 65 mm (10 x 10 cm) NVG: 4 mm (2.5 x 2.5 cm)	NV: 11 mm (10 x 10 cm) NVG: ---	NV: 0.012-mm dia. NVG: 1-mm dia.	General-purpose
E32-D14L	 6-mm dia.	NV: 44 mm (5 x 5 cm) NVG: 1.5 mm (2.5 x 2.5 cm)	NV: 8.8 mm (5 x 5 cm) NVG: ---	NV: 0.015-mm dia. NVG: 1.0-mm dia.	Side-view; long distance
E32-D24	 2-mm dia.	NV: 17 mm (2.5 x 2.5 cm) NVG: 1.6 mm (2.5 x 2.5 cm)	NV: 2.8 mm (2.5 x 2.5 cm) NVG: ---	NV: 0.012-mm dia. NVG: 1.0-mm dia.	Side-view; space saving

*Cannot be trimmed

Model	Appearance	Sensing distance (standard object) (NV: E3X-NV21; NVG: E3X-NVG21)		Min. sensing object (copper wire)	Features
		White paper	Black paper		
E32-D12F	 6-mm dia.	NV: 55 mm (5 x 5 cm) NVG: 4 mm (2.5 x 2.5 cm)	NV: 16 mm (5 x 5 cm) NVG: ---	NV: 0.012-mm dia. NVG: 0.5-mm dia.	Teflon-covered***; with-stands chemicals and harsh environments
E32-D51	 M6 screw	NV: 65 mm (10 x 10 cm) NVG: 5 mm (2.5 x 2.5 cm)	NV: 13 mm (10 x 10 cm) NVG: ---	NV: 0.012-mm dia. NVG: 1.0-mm dia.	Heat-resis-tive; resists 150°C
E32-D61	 M6 screw	NV: 50 mm (5 x 5 cm) NVG: 5 mm (2.5 x 2.5 cm)	NV: 10 mm (5 x 5 cm) NVG: ---	NV: 0.012-mm dia. NVG: 1.0-mm dia.	Heat-resis-tive; resists 300°C
E32-D73	 M4 screw 1.25-mm dia.	NV: 33 mm (5 x 5 cm) NVG: 3 mm (2.5 x 2.5 cm)	NV: 6.6 mm (5 x 5 cm) NVG: ---	NV: 0.012-mm dia. NVG: 1.0-mm dia.	Heat-resis-tive; resists 400°C
E32-R21 +E39-R3	 M6 screw Reflector E39-R1	NV: 25 to 250 mm (35-mm dia. min.)**	---	NV: 0.3-mm dia.	Transparent objects de-tection
E32-R16 +E39-R1	 Reflector E39-R1	NV: 150 to 1,500 mm (35-mm dia. min.)**	---	NV: 0.5-mm dia.	Transparent objects de-tection
E32-L25		NV: 3.3 mm (2.5 x 2.5 cm)	---	NV: 0.012-mm dia.	Limited reflective; detects wafers and small differ-ence in height
E32-L25A		NV: 3.3 mm (2.5 x 2.5 cm)	---	NV: 0.012-mm dia.	Limited reflective; detects wafers and small differ-ence in height
E32-L25L		NV: 7.2±1.8 mm (2.5 x 2.5 cm)	---	NV: 0.012-mm dia.	Limited reflective, long dis-tance; detects wafers and small differ-ence in height
E32-L24L		NV: 4±2 mm (2.5 x 2.5 cm)	---	NV: 0.012-mm dia.	Limited reflective, long dis-tance, side-view; detects wafers and small differ-ence in height

*Cannot be trimmed; **Standard object: opaque

***Teflon is a registered trademark of the Dupont Company and the Mitsui Dupont Chemical Company for their fluoride resin.

Note: Reflective Sensors: The Photoelectric Sensor may turn ON if the sensitivity is set to maximum, in which case, reduce the sensitivity.

Fine Through-beam Sensors

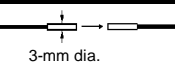
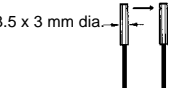
Model	Appearance	Sensing distance (standard object)* (NV: E3X-NV21)	Min. sensing object (opaque objects)	Features
E32-T22S	 3-mm dia.	NV: 650 mm (1.7-mm dia. min.)	NV: 0.2-mm dia.	General-purpose; detects wafers and small difference in height
E32-T24S	 3.5 x 3 mm dia.	NV: 480 mm (1.7-mm dia. min.)	NV: 0.1-mm dia.	Side-view; detects wafers and small dif-ference in height

*Standard object: opaque

Slot Sensors

Model	Appearance	Sensing distance (standard object)* (NV: E3X-NV21; NV: E3X-NVG21)	Min. sensing object (opaque objects)	Features
E32-G14		10 mm (slot width)** (4-mm dia. min.)	NV: 0.4-mm dia. NVG: 0.6-mm dia.	Slot through-beam; no optical axis adjustment required

*Standard object: opaque

** No-object teaching is not possible with the E32-G14 because the sensing distance of the E32-G14 is short and the light will be excessive. Perform with/without-object teaching instead.

High-precision Screen Sensors

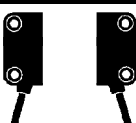
Model	Appearance	Slit width	Sensing distance (NV: E3X-NV21)	Min. sensing object* (horizontal beam)
E32-T16P		Not used	NV: 480 mm	NV: 1.3-mm dia. (0.6-mm dia.)
		0.5 mm wide	NV: 80 mm	NV: 1.3-mm dia. (0.4-mm dia.)
		1.0 mm wide	NV: 160 mm	NV: 1.3-mm dia. (0.5-mm dia.)

* Values not in parentheses represent sensing objects within the 11-mm sensing area and values in parentheses represent sensing objects in the center of the E32-T16P sensing area. The diameters of sensing objects in the above table represent sensing object sizes, on condition that the objects are not moving.

Sensing Direction

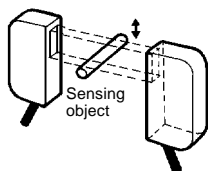

Mounting Bracket for E32-T16P (Option)

Sold in pairs.

Model	Applicable fibers
E39-L94	E32-T16P

Specifications

■ Ratings/Characteristics

Amplifier Unit

Item	E3X-NV21	E3X-NVG21
Indicator	Orange LED: Lit during output operation Green LED: Lit with stable light reception or no light	
Circuit protection	Reverse polarity, Output short-circuit	
Ambient illumination	Sunlight: 10,000 lx max.; Incandescent lamp: 3,000 lx max.	
Ambient temperature	Operating: -25°C to 55°C (with no icing) Storage: -40°C to 70°C (with no icing)	
Ambient humidity	Operating: 35% to 85% (with no condensation)	
Insulation resistance	20 MΩ min. (at 500 VDC)	
Dielectric strength	1,000 VAC, 50/60 Hz for 1 min	
Vibration resistance	10 to 55 Hz, 1.5-mm double amplitude or 300 m/s ² (approx. 30G) for 2 hrs each in X, Y, and Z directions	
Shock resistance	500 m/s ² (approx. 50G) for 3 times each in X, Y, and Z directions	
Enclosure rating	IEC IP66 (with protective cover in place) (see note)	
Material	Case: Heat-resistive ABS; Cover: Polycarbonate	
Weight (with 2-m cord)	Approx. 100 g	

Note: The enclosure rating of the Amplifier is IP65 when the Amplifier is connected to a Fine Fiber Sensor, a Heat-resistive Sensor (such as the E32-T61, E32-D61, or E32-D73), a Sleeve Fiber Sensor, or the E32-M21. The enclosure rating of the Amplifier with no protective cover is IP50.

Fiber Unit

Common

Ambient storage temperature	Heat-resistive fiber: -40°C to 110°C (with no icing) Other fibers: -40°C to 70°C (with no icing)
Ambient storage humidity	Operating: 35% to 95% (with no condensation)
Vibration resistance	10 to 55 Hz, 1.5-mm double amplitude for 2 hrs each in X, Y, and Z directions
Shock resistance	500 m/s ² (approx. 50G) for 3 times each in X, Y, and Z directions

Through-beam (Separate) Sensors

Model	Ambient temperature	Ambient humidity	Permissible bending radius	Material	Enclosure rating
E32-T11L	Operating: -40°C to 70°C (with no icing)	Operating: 35% to 85%	25 mm min.	Black polyethylene	IEC IP67
E32-T12L					
E32-T21L					
E32-T22L					
E32-TC200					
E32-TC200B					
E32-TC200B4					
E32-T22					
E32-TC200E					
E32-TC200F					
E32-TC200F4					
E32-TC200A					
E32-T11			4 mm min.	Vinyl chloride	
E32-T21			25 mm min.	Black polyethylene	
E32-TC200C					
E32-TC200D					
E32-TC200D4					
E32-T14L					
E32-T24					
E32-T14	40 mm min.	Teflon-covered* black polyethylene			
E32-T17L					
E32-T12F	Operating: -30°C to 70°C (with no icing)		25 mm min.	Black polyethylene	
E32-T14F					
E32-T16	Operating: -40°C to 70°C (with no icing)		35 mm min.	Fluoride resin	
E32-M21					
E32-T51	Operating: -40°C to 150°C** (with no icing)		25 mm min.	SUS	
E32-T54					
E32-T61	Operating: -40°C to 300°C (with no icing)				

*Teflon is a registered trademark of the Dupont Company and the Mitsui Dupont Chemical Company for their fluoride resin.

**When used continuously between -40°C and 130°C.

Reflective Sensors

Model	Differential travel	Ambient temperature	Ambient humidity	Permissible bending radius	Material	Enclosure rating		
E32-D11L	20% of max. of sensing distance	Operating: -40°C to 70°C (with no icing)	Operating: 35% to 85%	25 mm min.	Black polyethylene	IEC IP67		
E32-D12								
E32-D21L								
E32-D22L								
E32-DC200								
E32-DC200B E32-DC200B4								
E32-DC200E								
E32-DC200F E32-DC200F4								
E32-D11							4 mm min.	Vinyl chloride
E32-D21							25 mm min.	Black polyethylene
E32-DC200C								
E32-DC200D E32-DC200D4								
E32-DC9G E32-DC9G4								
E32-D33								
E32-CC200								
E32-D32								
E32-D32L								
E32-D14L								
E32-D24								
E32-D12F				Operating: -30°C to 70°C (with no icing)	40 mm min.		Teflon-covered black polyethylene*	
E32-D51	Operating: -40°C to 150°C (with no icing)**	35 mm min.	Fluoride resin					
E32-D61	Operating: -40°C to 300°C (with no icing)	25 mm min.	SUS					
E32-D73	Operating: -40°C to 400°C (with no icing)							
E32-R21 with E39-R3	Operating: -40°C to 70°C (with no icing)			Black polyethylene				
E32-R16 with E39-R1	Operating: -25°C to 55°C (with no icing)				IEC IP66			
E32-L25***	5% of max. of sensing distance			Operating: -40°C to 70°C (with no icing)	10 mm min. (average at 10% decrease of sensing distance)	Reinforced polyethylene	IEC IP50	
E32-L25A***								
E32-L25L***				Operating: -40°C to 105°C				
E32-L24L***								

*Teflon is a registered trademark of the Dupont Company and the Mitsui Dupont Chemical Company for their fluoride resin.

**When used continuously between -40°C and 130°C.

***Beam size: 2-mm dia.

Fine Through-beam Sensors

Model	Beam size	Ambient temperature	Ambient humidity	Permissible bending radius*	Material	Enclosure rating
E32-T22S	13-mm dia. (at a distance of 200 mm)	Operating: -40°C to 70°C (with no icing)	Operating: 35% to 85%	10 mm min.	Reinforced laminated vinyl chloride	IEC IP67
E32-T24S						

*Average at 70% decrease of sensing distance

Slot Sensors

Model	Ambient temperature	Ambient humidity	Permissible bending radius	Material	Enclosure rating
E32-G14	Operating: -40°C to 70°C (with no icing)	Operating: 35% to 85%	25 mm min.	Fiber sheath: Black polyethylene	IEC IP67



High-precision Screen Fiber Unit

Model	Ambient temperature	Ambient humidity	Permissible bending radius*	Material	Enclosure rating
E32-T16P **	Operating: -40°C to 70°C (with no icing)	Operating: 35% to 85%	10 mm min.	Sensing head: Heat-resistant ABS Fiber sheath: Vinyl chloride	IEC IP50

*Average at 10% decrease of sensing distance

**Attachments: two slits each (0.5 mm and 1.0 mm wide)

Attachments



Name		Small Spot Lens Unit	Long Distance Lens Unit			
Applications		Detection over 0.5-mm-dia. spots	Increasing sensing distance			
Model		E39-F3A	E39-F1			
Appearance		Reflective 	Through-beam (separate) 			
Applicable fibers		E32-D32	E32-T11L	E32-TC200 E32-T61	E32-T11	E32-TC200C
With E3X-NV21	Sensing distance	22 mm*	1,280 mm	2,100 mm	1,400 mm	850 mm
	Standard object	White paper 2.5 x 2.5 cm	Opaque objects: 4-mm dia. min.			
With E3X-NVG21	Sensing distance	---	120 mm	190 mm**	120 mm	100 mm
	Standard object	---	Opaque objects: 4-mm dia. min.			
Directivity		---	5° to 40°			
Differential travel		20% of sensing distance	---			
Ambient temperature		Operating: -40°C to 70°C	E32-T61: -40°C to 200°C (Do not exceed the operating temperature of the fiber.)			
Material	Shaft	Aluminum	Brass			
	Lens	Optical glass				
	Base	---				
	Reflector	---				

*When inserting 15 mm.

**E32-T61: 130 mm

Name		Side-view Unit			
Applications		Changing the sensing direction at °90			
Model		E39-F2			
Appearance		Through-beam (separate) 			
Applicable fibers		E32-T11L	E32-TC200	E32-T61 E32-T11	E32-TC200C
With E3X-NV21	Sensing distance	265 mm	265 mm	210 mm	105 mm
	Standard object	Opaque objects: 3-mm dia. min.			
With E3X-NVG21	Sensing distance	10 mm	19 mm	10 mm	6 mm
	Standard object	Opaque objects: 4-mm dia. min.	Opaque objects: 3-mm dia. min.		
Directivity		20° to 60°			
Differential travel		---			
Ambient temperature		E32-T61: -40°C to 200°C (Do not exceed the operating temperature of the fiber.)			
Material	Shaft	Brass			
	Lens	Optical glass			
	Base	---			
	Reflector	---			

Name			Lens-equipped Reflective Unit		
Applications			Converting through-beam sensors to reflective sensors		
Model			E39-F3		
Appearance			Reflective 		
Applicable fibers			E32-T11L	E32-TC200	E32-T61
With E3X-NV21	Sensing distance (standard object)	White paper	55 to 160 mm*	85 to 110 mm*	
		Black paper	---	16 to 18 mm*	17 to 19 mm*
With E3X-NVG21	Sensing distance (standard object)	White paper	---	10 to 15 mm* (2.5 x 2.5 cm)	
		Black paper	---	---	
Directivity			---		
Differential travel			20% of sensing distance		
Ambient temperature			E32-T61: -40°C to 200°C (Do not exceed the operating temperature of the fiber.)		
Material	Shaft		Brass		
	Lens		Optical glass		
	Base		Aluminum		
	Reflector		---		

Name			Lens-equipped Reflective Unit		Side-view Reflective Unit
Applications			Converting through-beam sensors to reflective sensors		Converting through-beam to reflective sensor
Model			E39-F3		E39-F5
Appearance			Reflective 		Reflective 
Applicable fibers			E32-T11	E32-TC200C	E32-TC200A
With E3X-NV21	Sensing distance (standard object)	White paper	90 to 110 mm*	85 to 110 mm*	
		Black paper	---	6 to 10 mm*	
With E3X-NVG21	Sensing distance (standard object)	White paper	---		
		Black paper	---		
Directivity			---		
Differential travel			20% of sensing distance		
Ambient temperature			E32-T61: -40°C to 200°C (Do not exceed the operating temperature of the fiber.)		Operating: -40°C to 70°C
Material	Shaft		Brass		---
	Lens		Optical glass		---
	Base		Aluminum		Brass
	Reflector		---		Stainless

*These values are possible when the angle of the E39-F3 is smallest (parallel).

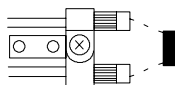

Beam Spot Characteristics

E39-F3A with E32-D32

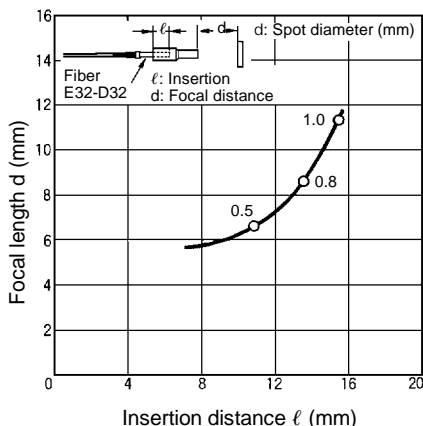

Spiral Tubes

Model	E39-F32A5	E39-F32A	E39-F32B5	E39-F32B	E39-F32C5	E39-F32C	E39-F32D5	E39-F32D
Appearance								
Length (L)	500 mm	1,000 mm	500 mm	1,000 mm	500 mm	1,000 mm	500 mm	1,000 mm
Applicable fiber	E32-DC200E E32-DC200F(4) E32-D21		E32-TC200E E32-TC200F(4) E32-T21 E32-T21L		E32-TC200 E32-TC200B(4) E32-T11 E32-T51 E32-T11L		E32-DC200 E32-DC200B(4) E32-CC200 E32-D11 E32-D51 E32-D11L	
Ambient temperature	Operating: -40°C to 150°C (Do not exceed the operating temperature of the fiber)							
Ambient humidity	Operating: 35% to 85%							
Permissible bending radius	30 mm min.							
Tensile strength	Between head connector and end cap with tube: 15 kgf S cm max. (1.5 N S m) Tube: 20 kgf S cm max. (2 N S m)							
Compression load	Tube: 3 kg max. (29.4 N)							

Accessories

Name	Fiber Cutter	Fine-fiber Attachment	Fiber Connector	Sleeve Bender
Model	E39-F4	E39-F9	E39-F10	E39-F11
Appearance				
Features	Used to cut fibers to desired lengths	Used when inserting fine fibers into the amp	Used to connect fibers when broken	Used to bend fiber sleeves
Applicable fiber	All models equipped with fibers that can be trimmed.	E32-DC200E, -TC200E E32-DC200F(4), -TC200F(4) E32-D21, -D21L, -D22L E32-T21, -T21L, -T22L E32-D32, -T22 E32-D24, -T24 E32-D33 E32-R21	E32-DC200, -TC200 E32-DC200B(4), -TC200B(4) E32-TC200A E32-T14, -G14 E32-D11L, -T11L, -T12L E32-D14L, -T14L E32-T17L	E32-TC200B(4) E32-TC200D(4) E32-DC200F(4), -TC200F(4) E32-DC9G(4)

■ Light Source Color Selection

To distinguish two colors, select a light source color that creates a large difference in the reflection rate between the two colors.

Refer to the following table to select the best light source color to distinguish colors.

Reflection Rates

Red Light Source (E3X-NV)

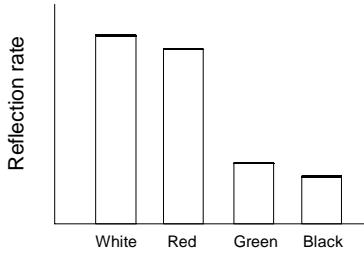

Green Light Source (E3X-NVG)

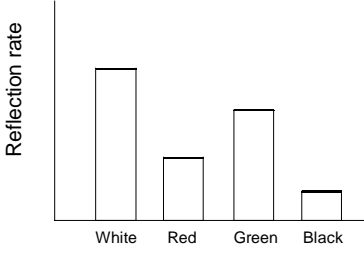

Colors to be distinguished	Light source	
	Red	Green
White - Red		Yes
White - Green	Yes	
Red - Green	Yes	
Black - Red	Yes	
Black - Green		Yes
White - Black	Yes	Yes

Engineering Data

■ Excess Gain Ratio (Typical)

E32-TC200

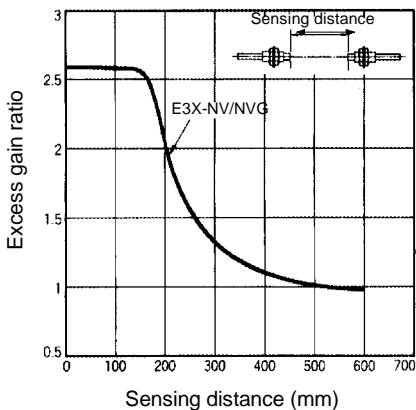

E32-T11L

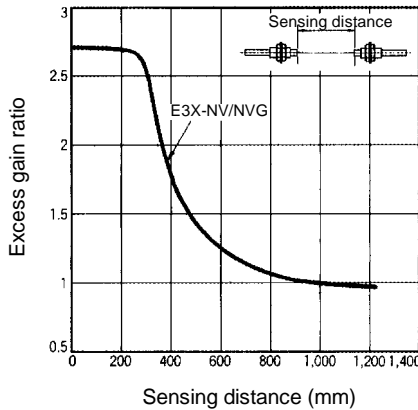

E32-T11L with E39-F1

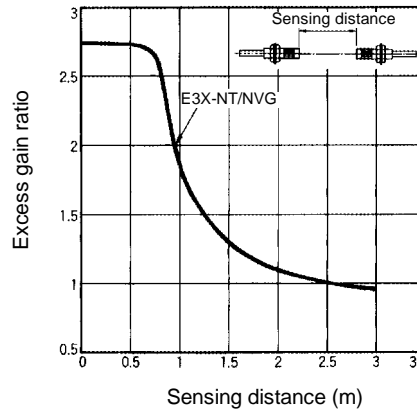

E32-T11L with E39-F2

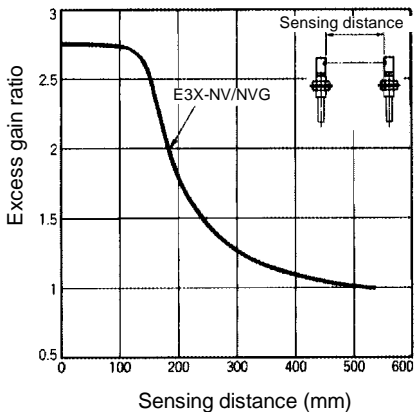

E32-T11L with E39-F3

(When the angle of the E39-F3 is at its minimum (parallel).)

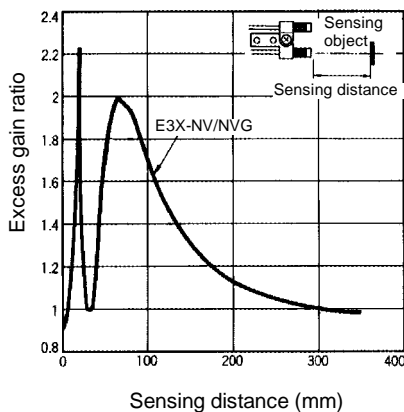

E32-T21L

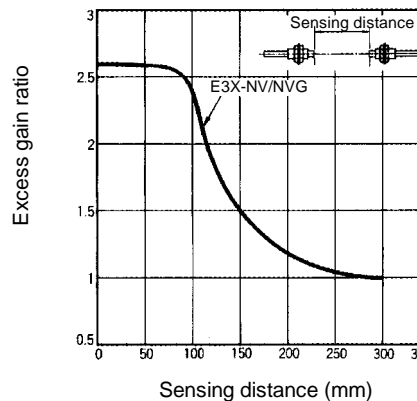

E32-T14L

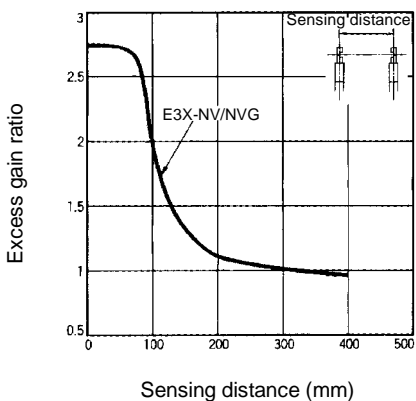

E32-T17L

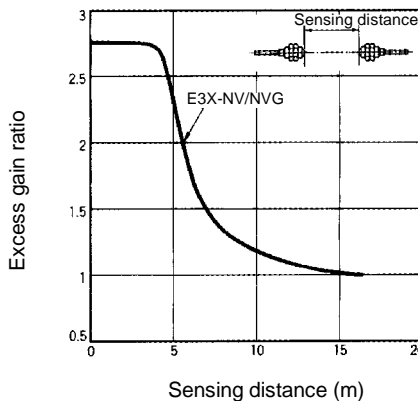

E32-T16

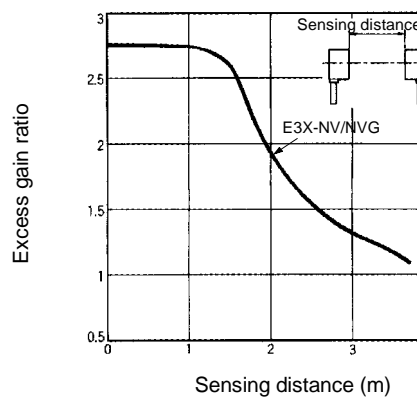

E32-DC200

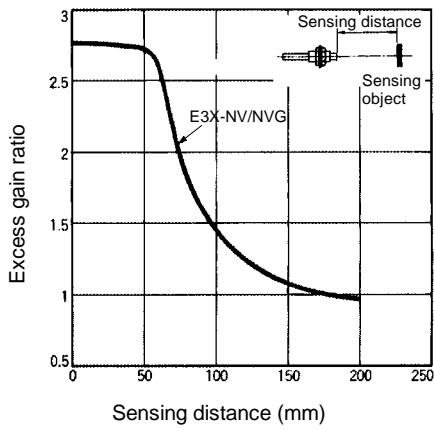

E32-D11L

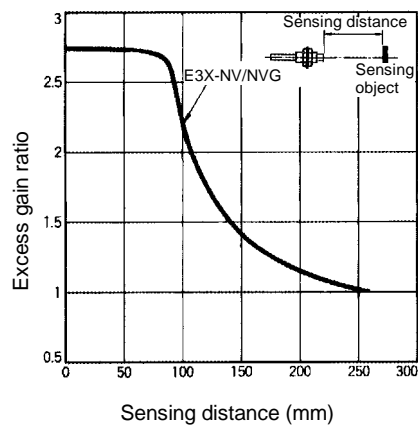

E32-D21L

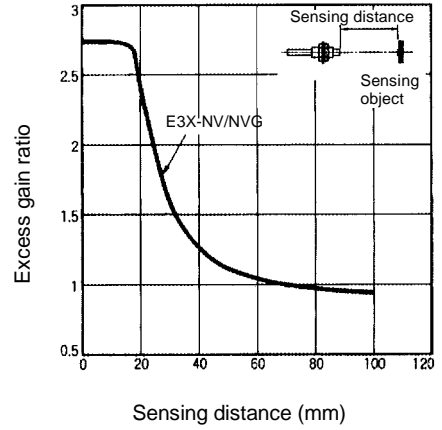

E32-T16P

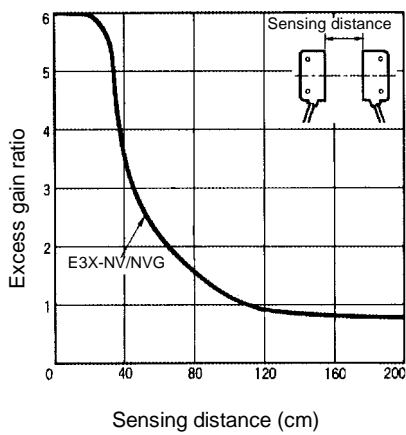

E32-CC200

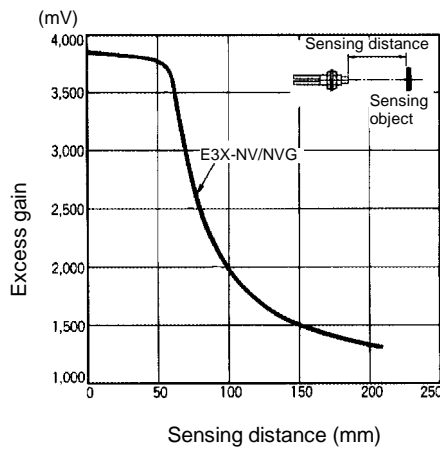

E32-T22S

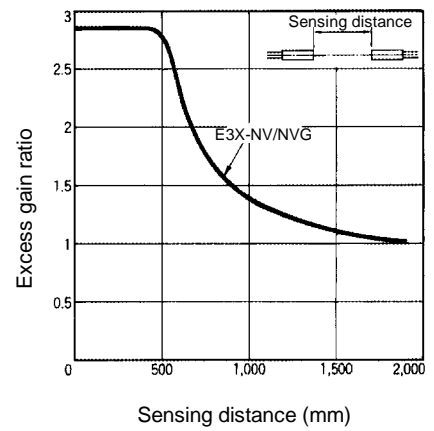

E32-T24S

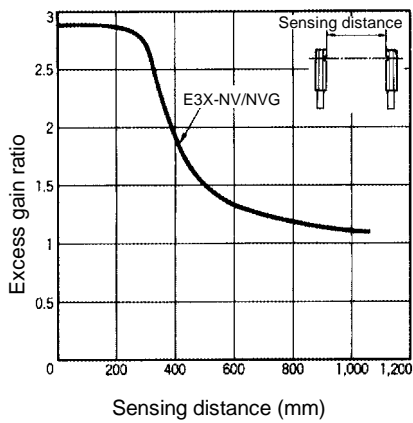

E32-T54

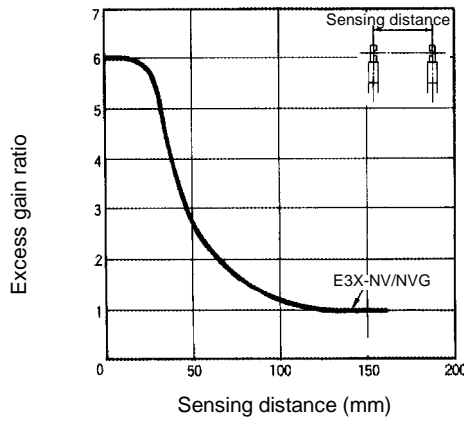

E32-T14F

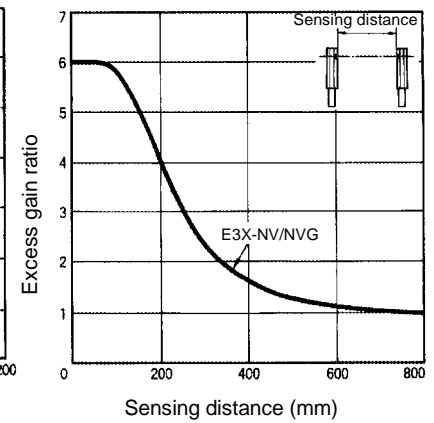

■ Operating Range (Typical)

With standard sensing object at max. sensitivity.

E32-DC200

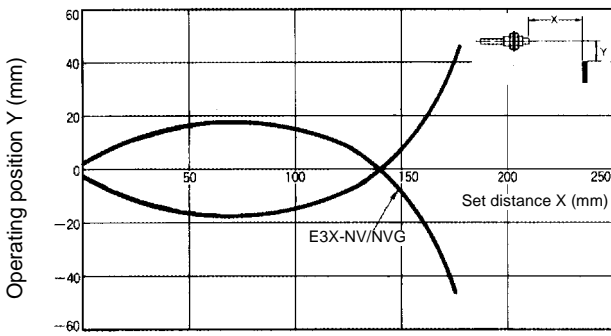

E32-D11L

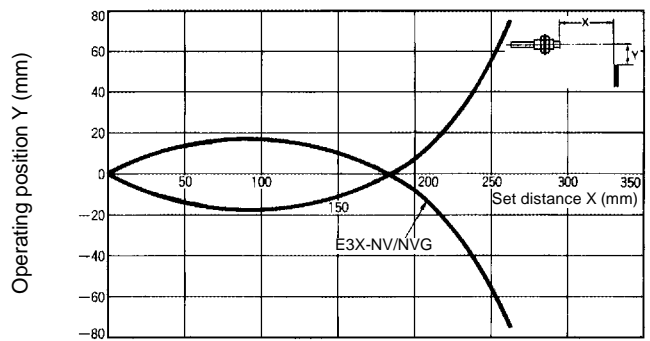

E32-D21L

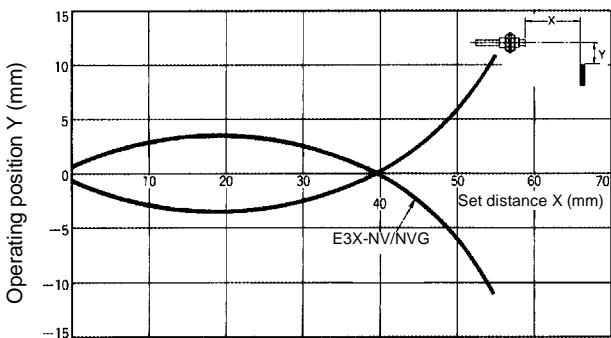

E32-CC200

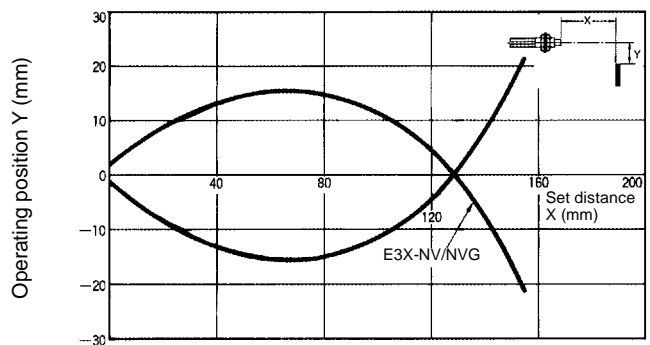

E32-L24L

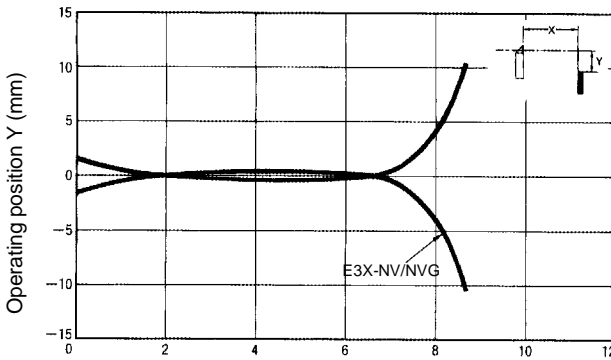

■ Parallel Operating Range (Typical)

At max. sensitivity.

E32-TC200

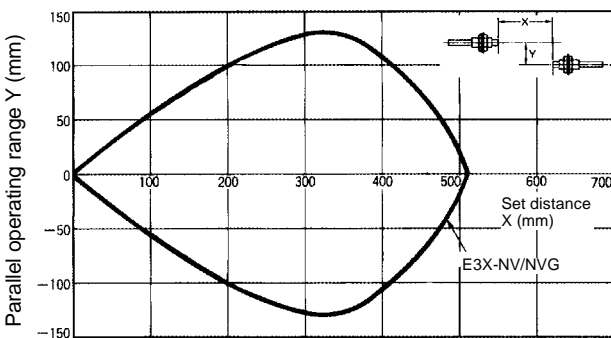

E32-T11L

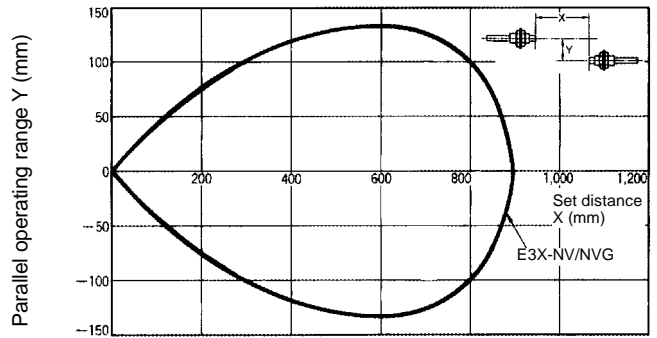

E32-T11L with E39-F1

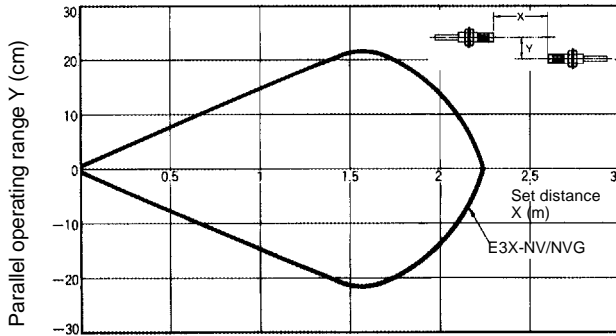

E32-T11L with E39-F2

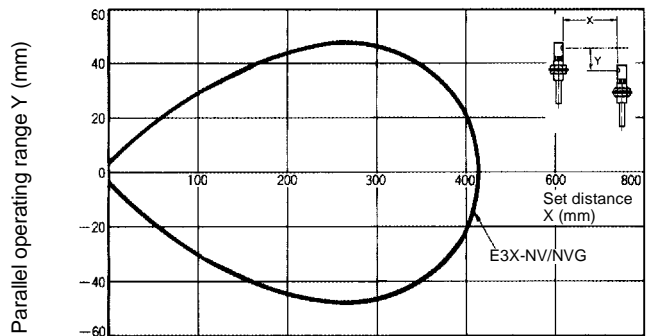

E32-T21L

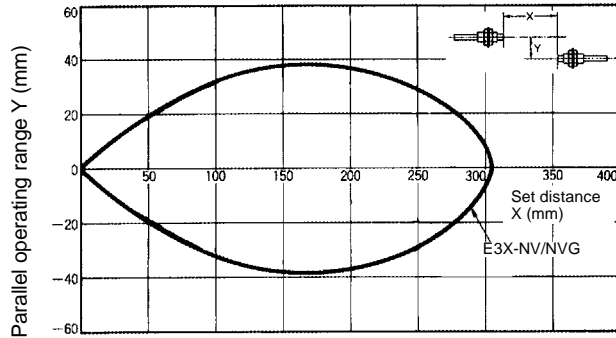

E32-T14L

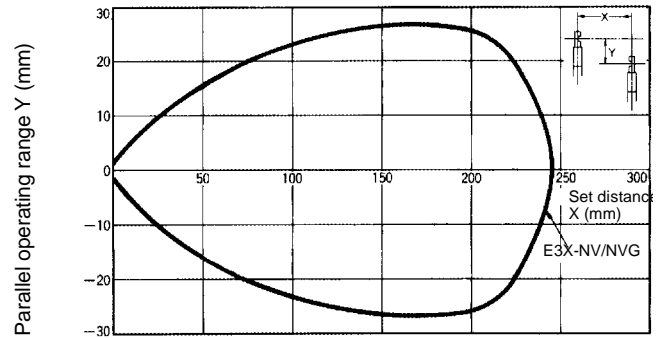

E32-T17L

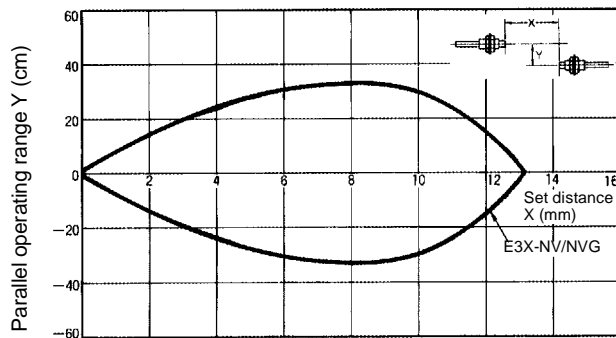

E32-T12F

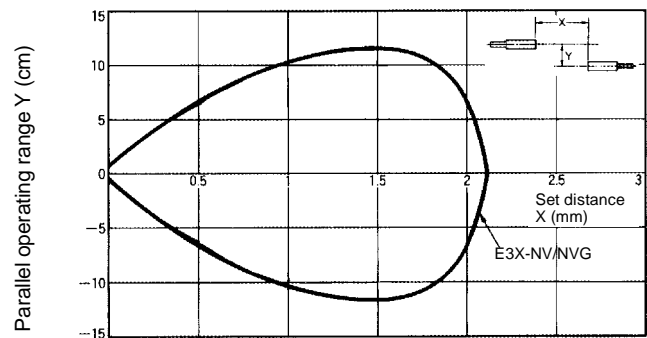

E32-T22S

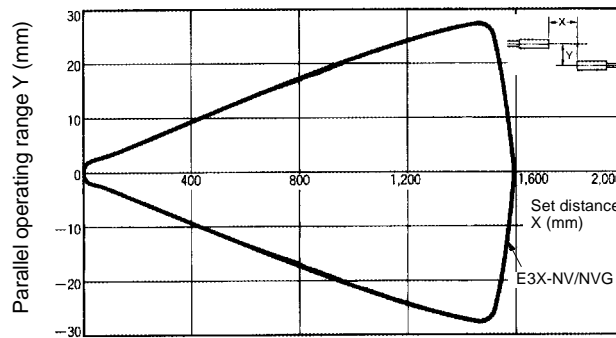

E32-T24S

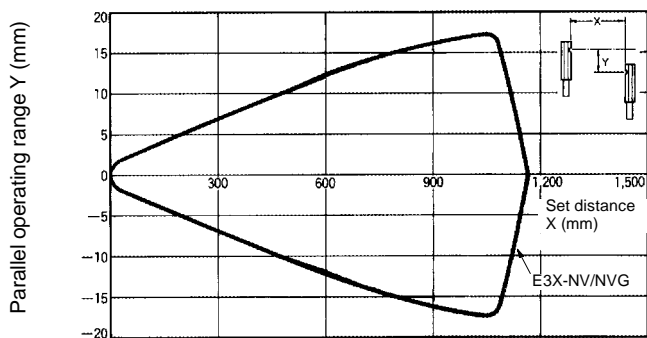

■ Sensing Objects vs. Operating Range (Typical)

E32-DC200 with E3X-NV/NVG

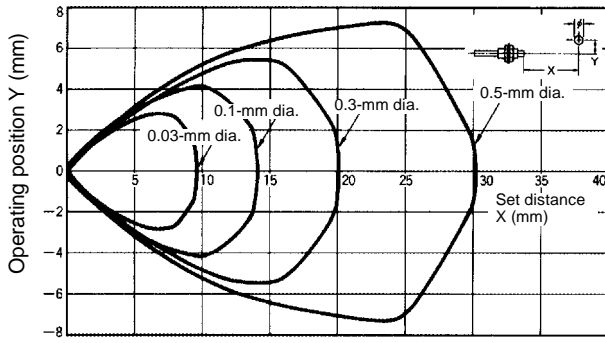

E32-D22L with E3X-NV/NVG

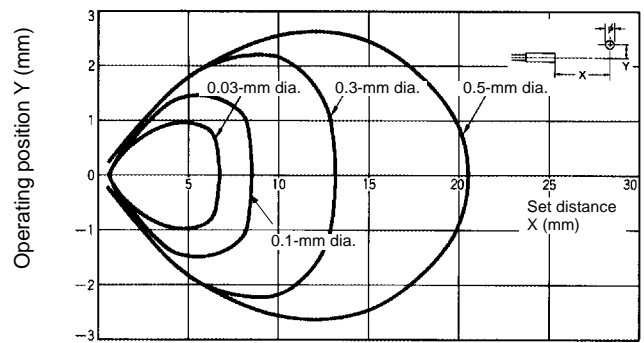

E32-D11L with E3X-NV/NVG

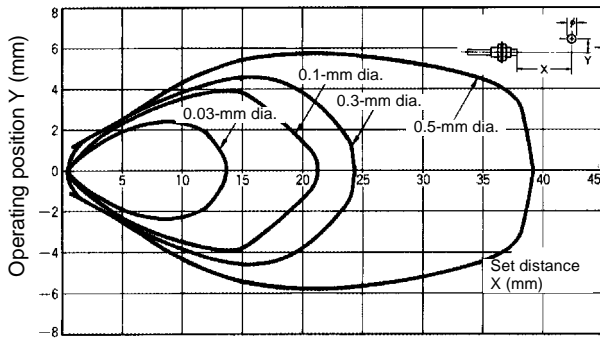

E32-D33 with E3X-NV/NVG

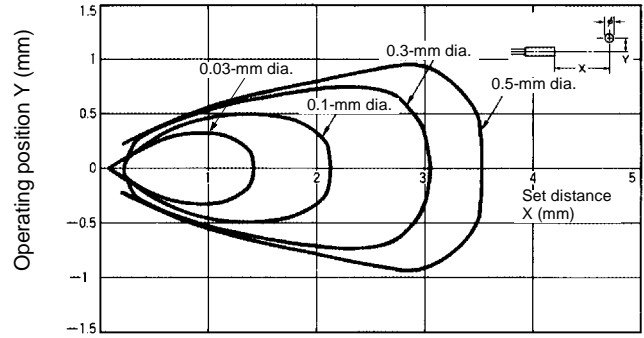

E32-CC200 with E3X-NV/NVG

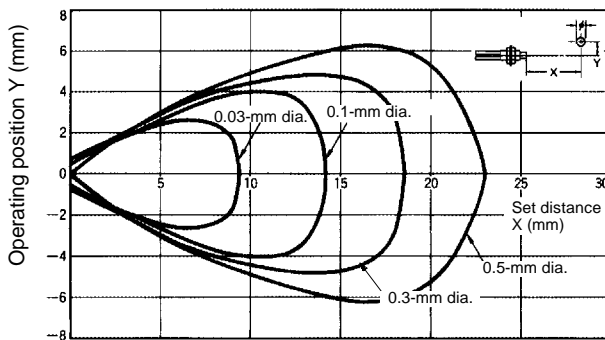

E32-D32 with E3X-NV/NVG

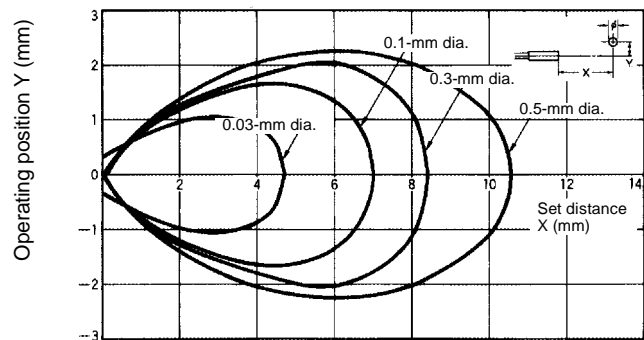

E32-T54

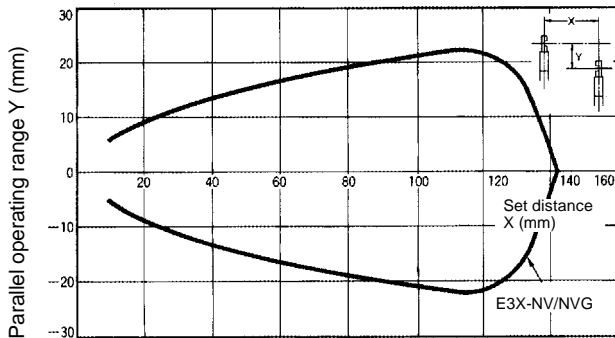

E32-T14F

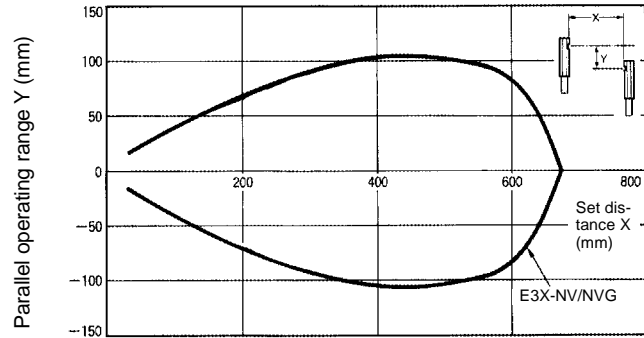

Operation

■ Output Circuits

E3X-NV21/NVG21

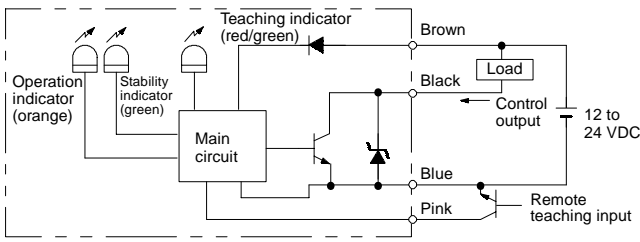

Timing Chart

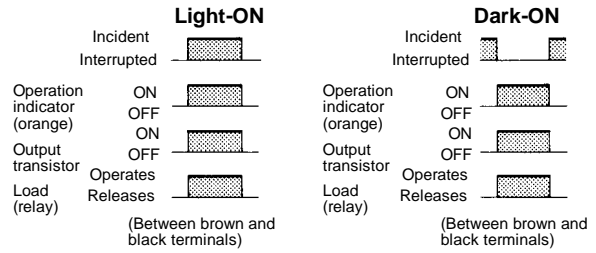

■ With/Without-object Teaching, No-object Teaching, Maximum Sensitivity Setting

Refer to the following table to select the most suitable sensitivity setting method.

Sensitivity setting method	Maximum sensitivity setting	No-object teaching	With/Without-object teaching
Typical application	Detection of the existence of objects that interrupt light perfectly Detection of objects with no background objects	If teaching is impossible by stopping the movement of sensing objects	Detection of a slight difference in reflection Color discrimination Background objects with unstable reflection Detection of object surface irregularities
		To detect bright or dark objects by teaching only with background objects Elimination of background object influence	

- Note:**
1. If the set distance is very short (i.e., 0 to 12 mm for the E32-TC200 and 0 to 4 mm for the E32-DC200), no-object teaching is not possible due to excessive light, in which case, perform with/without-object teaching.
 2. When closely connecting two to three Fiber Units to more than one E3X-NV/NVG, perform with/without-object teaching, in which case teaching must be performed on a single E3X-NV/NVG at a time. Therefore, turn on only the E3X-NV/NVG on which teaching is performed. If all the E3X-NV/NVGs are turned on, interrupt the emitters of the Fiber Units on which teaching is not performed.

■ No-object Teaching with an Initial Operating Level Compensation Function With Reflective (Light-ON) Fiber Unit

1. Teaching button is pressed once.

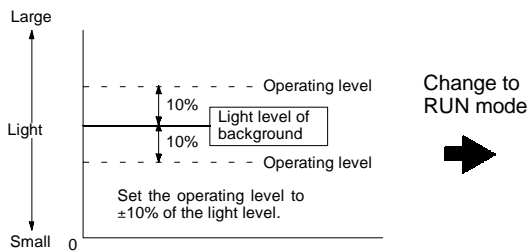

2. The first sensing object is in the sensing area.

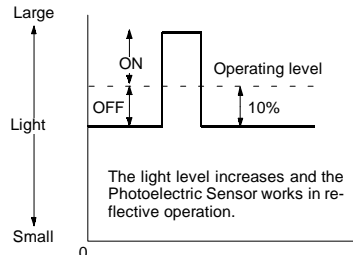

3. Sensing objects continue to pass through the sensing area.

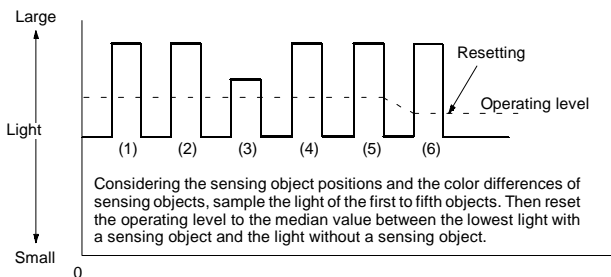

Note: If the light value up to the fifth object is at least twice as large as the operating level, the initial set operating level (10%) will be maintained.

With Through-beam (Dark-ON) Fiber Unit

1. Teaching button is pressed once.

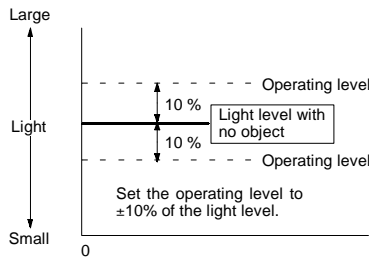

Change to RUN mode

2. The first sensing object is in the sensing area.

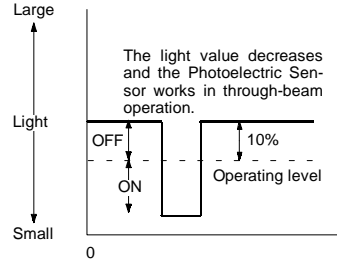

3. Sensing objects continue to pass through the sensing area.

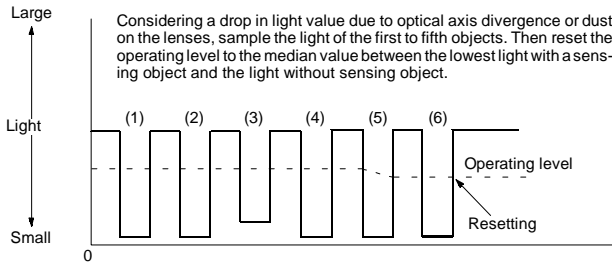

- Note:**
1. After no-object teaching, when the E3X-NVj is turned off and on, the operation level will be set to the +10% of the initial light level (refer to the above (1)) in reflective operation and -10% of the initial light level in through-beam operation and stand by.
 2. After performing no-object teaching and changing to RUN mode, until the first sensing object is in the sensing area, the control output will be prohibited (OFF). The control output will be determined when the first sensing object is detected.
 3. The initial operating level compensation function will operate after teaching and/or after the E3X-NVj is turned on.
 4. During no-object teaching, after the E3X-NVj is in RUN mode, the E3X-NVj requires approximately 60 ms to determine the operating level from the time the first sensing object is in the sensing area. After the operating level is determined, the E3X-NVj will operate with a normal response speed of 500 μs.

Remote Teaching Function

Remote Teaching Function

In principle, the remote teaching function of the E3X-NVj should be used for initial teaching. Basically, the method of remote teaching is the same as that of sensitivity setting. In remote teaching, instead of pressing the teaching button, teaching is performed with a remote teaching input signal.

1. Set the mode selector to RUN.
2. The following signal conditions must be given as remote teaching input conditions.

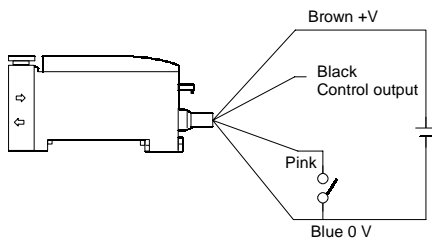

1. If remote teaching is not performed, cut the pink wire at the base or connect the pink wire to the +V terminal.
2. After remote teaching input setting is finished, the E3X-NVj will be ready to detect objects in approximately one second.

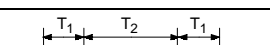
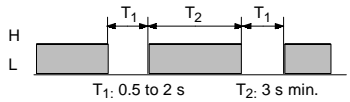
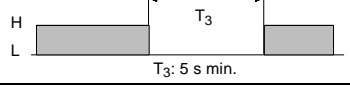
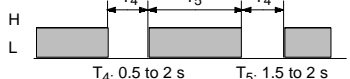
Power supply		ON  OFF 
Remote teaching input	With/Without-object teaching	 T ₁ : 0.5 to 2 s T ₂ : 3 s min.
	Maximum sensitivity setting	 T ₃ : 5 s min.
	No-object teaching	 T ₄ : 0.5 to 2 s T ₅ : 1.5 to 2 s

Optical Axis Adjustment (Super-flashing Function)

Set the mode selector of the E3X-NVj to TEACH. The super flashing function of E3X-NVj will be activated. When the optical axes of the fiber heads are divergent and the light value decreases by approximately 10% of the maximum value, the tip of the emitting fiber will start flashing and the built-in buzzer will beep. At this time, if the optical axes are divergent, adjust the axes. The peak light value will be memorized by the E3X-NVj. Do not press the teaching button before or while adjusting the optical axes, otherwise, the super-flashing function will not operate.

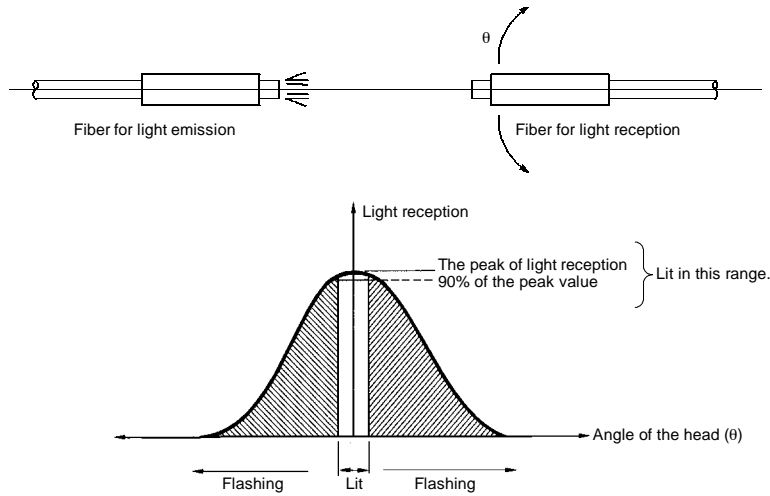

Dimensions

Note: All units are in millimeters unless otherwise indicated.

E3X-NV
E3X-NVG

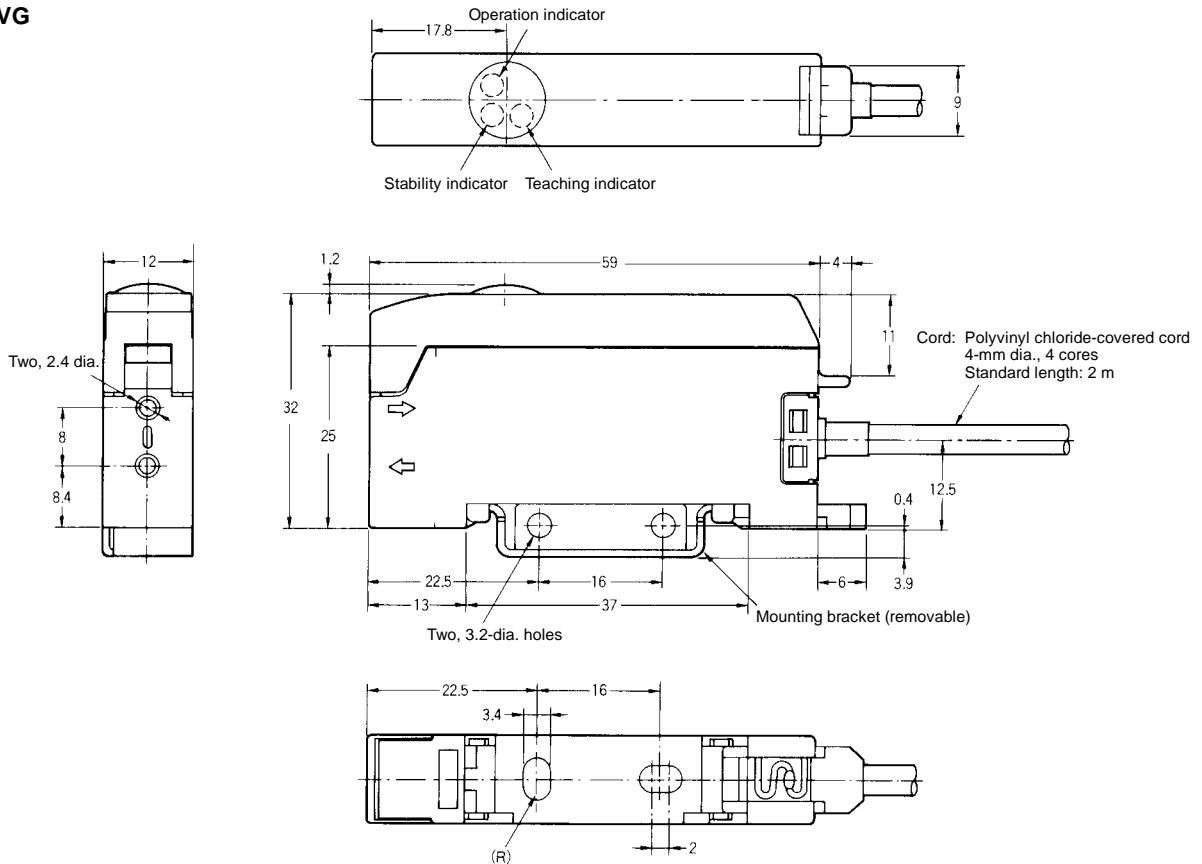

Installation

■ Connection

Connection with S3D2 Sensor Controller

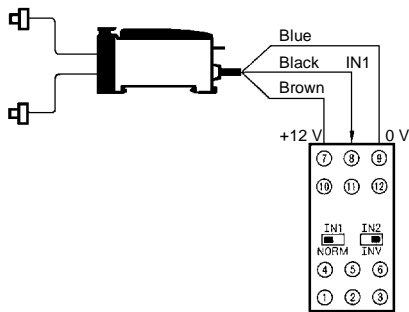

Note: A maximum of two E3X-NVj Sensors can be connected.

Connection with S3D8 Sensor Controller

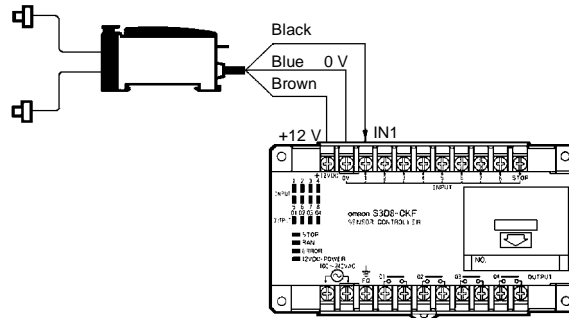

Note: 1. The E3X-NVj will switch to reverse operation by pressing the L Key.
2. A maximum of eight E3X-NVj Sensors can be connected.

Precautions

⚠ WARNING

The voltage supplied to the E3X-NV/NVG must be within the rated voltage range. If a voltage exceeding the rated upper limit is imposed on the E3X-NV/NVG, the E3X-NV/NVG may explode or burn.

Connect each power line of the E3X-NV/NVG correctly, otherwise the E3X-NV/NVG may explode or burn.

Do not short-circuit the load connected to the E3X-NV/NVG, otherwise the E3X-NV/NVG may explode or burn.

⚠ Caution

■ Fiber Unit

Fiber Connection and Disconnection

The E3X-NVj Amplifier has a push lock. Connect or disconnect the fibers to or from the E3X-NVj Amplifier using the following procedures:

1. Connection

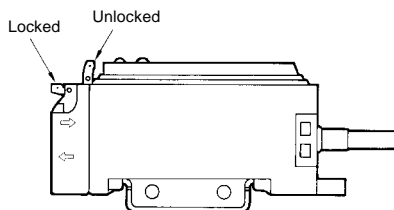

After inserting the fiber into the Unit, push down the lock lever to secure the fiber.

After cutting the fibers with the Fiber Cutter (E39-F4), place an insertion mark on the fiber so that it can be properly inserted into the Amplifier. Insert the fiber into the Amplifier up to this insertion mark.

2. Disconnection

Push up the lock lever so that the fiber can be pulled out. In order not to damage the fiber, make sure that the fiber is unlocked before pulling out the fiber.

3. The fiber must be locked or released in a temperature range of -10° to 40°C .

■ Amplifier Units

Mounting

Mounting

1. Mount the front part on the mounting bracket (sold together) or a DIN track.
2. Press the back part onto the mounting bracket or the DIN track.

Note: Do not mount the back part onto the mounting bracket or the DIN track first and then mount the front part on the mounting bracket or the DIN track, or the mounting strength of the Amplifier Unit may decrease.

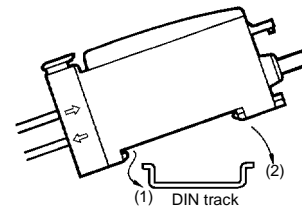

Dismounting

By pressing the Amplifier Unit in direction (3) and lifting the fiber insertion part in direction "4" as shown in the following, the Amplifier can be dismounted with ease.

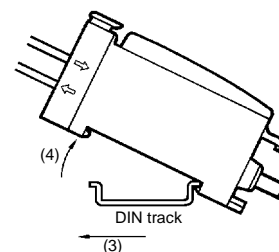

In the case of side mounting, attach the mounting bracket on the Amplifier first, and secure the Amplifier with M3 screws and washers. The diameter of the washers should be 6 mm max.

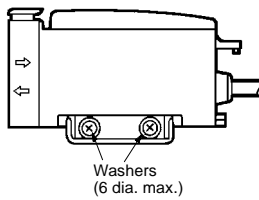

Pull back the gray rail on the rear bottom with a flat-blade screwdriver so that the Amplifier can be dismantled with ease.

Turning Power On

After the E3X-NVj is turned on, the E3X-NVj will be ready to operate in 100 ms maximum. If power is supplied to the E3X-NVj and the load is connected to the E3X-NVj independently, be sure to turn on the power supply connected to the E3X-NVj first.

When the E3X-NVj is turned on or off, no control output will be ON, even though the operation indicator of the E3X-NVj will be lit for an instant.

Mutual Interference Protection Function

When closely connecting two to three Fiber Units to more than one E3X-NVj, perform with/without-object teaching, in which case teaching must be performed on a single E3X-NVj at a time. Therefore, turn on only the E3X-NVj on which teaching is performed. If all the E3X-NVj are turned on, interrupt the emitters of the Fiber Units on which teaching is not performed.

Power interruptions or noise caused by static electricity or other causes can result in write errors during any part of the teaching process from teaching initial operating levels without a workpiece to final compensations. These errors include buzzers, lighting of teaching indicators, simultaneous flashing of red/green indicators, lighting of operation indicators, and lighting or flashing of stability indicators. If any of these occur, re-input teaching using the teaching button on the Amplifier.

Unlike the case with teaching errors, if any memory error occurs, red/green teaching indicators will flash simultaneously, and operation indicators and stability indicators will also flash.

Others

When power is off:

The moment power is turned off, the E3X-NVj could output a pulse signal which could affect the operation of the devices connected to it. This will happen more often if power is supplied to the E3X-NVj from an external power supply, thus affecting the connected timer and counter. Use a built-in power supply as much as possible to avoid this.

In the case of the cord is extended, use a wire with 0.3 mm² min. The total length of the cord should be 100 m max.

Power supply:

If a standard switching regulator is used as a power supply, the frame ground (FG) terminal and the ground (G) terminal must be grounded, or otherwise the E3X-NVj can malfunction, influenced by the switching noise of the power supply.

The supplied voltage must be within the rated voltage range. Unregulated full- or half-wave rectifiers must not be used as power supplies.

Do not lay wiring to the Optical Sensor together with power lines in the same piping or ducts. Doing so will cause induction between the lines, possibly resulting in faulty operation or destruction. Always lay wiring to the Optical Sensor in separate or dedicated piping.

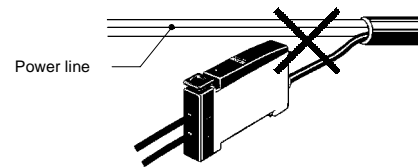

ALL DIMENSIONS SHOWN ARE IN MILLIMETERS.

To convert millimeters into inches, multiply by 0.03937. To convert grams into ounces, multiply by 0.03527.

Cat. No. E249-E1-2 **In the interest of product improvement, specifications are subject to change without notice.**

OMRON Corporation

Systems Components Division H.Q.
28th Fl., Crystal Tower Bldg.
1-2-27, Shiromi, Chuo-ku,
Osaka 540 Japan
Phone: 06-949-6012 Fax: 06-949-6021

Printed in Japan
1296-1M (1195) a