

## Metal Head Proximity Sensor



## E2ES

### Tough Metal Head Ensures a Long Service Life with Minimal Wear and Tear

- Stainless steel component of mono-block construction incorporates a sensor head and base.
- Stainless steel sensor head ensures a long service life with minimal wear and tear.
- Tough sensor head is not damaged by workpieces coming into contact.
- Operates without being influenced by aluminum cut-out powder.
- Easy-to-use DC two-wire models.



### Ordering Information

Type	Size	Sensing distance	Output configuration	Model
Non-shielded 	M18	 4 mm	DC 2-wire (normally open)	E2ES-X4D1
	M30	 8 mm		E2ES-X8D1

### Application Example

#### Automobile Assembly Line

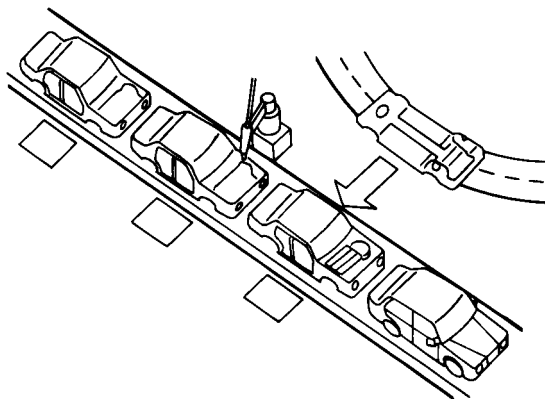

# Specifications

## ■ Ratings/Characteristics

Item	Type Model	DC 2-wire models	
		E2ES-X4D1	E2ES-X8D1
Sensing distance		4 mm±10%	8 mm±10%
Supply voltage (operating voltage range)		12 to 24 VDC, ripple (p-p) 10% max. (10 to 30 VDC)	
Leakage current		0.8 mA max.	
Sensing object		Ferrous metal (refer to <i>Engineering Data</i> for non-ferrous metal)	
Setting distance		0 to 2.8 mm	0 to 5.6 mm
Standard object (iron)		30 x 30 x 1 mm	54 x 54 x 1 mm
Differential travel		20% max. of sensing distance	
Response frequency		12 Hz	8 Hz
Operation (with sensing object approaching)		Load ON	
Control output		3 to 100 mA	
Circuit protection		Surge absorber, load short-circuit protection	
Indicator		Operation indicator (red LED), operation set indicator (green LED)	
Ambient temperature		Operating: 0°C to 50°C (with no icing)	
Ambient humidity		Operating: 35% to 95%	
Temperature influence		±20% max. of sensing distance at 23°C in temperature range of 0°C to 50°C	
Voltage influence		12 to 24 VDC, ±2.5% max. of sensing distance in rated voltage ±15%	
Residual voltage		3.0 V max. (under load current of 100 mA with cable length of 2 m)	
Insulation resistance		50 MΩ min. (at 500 VDC) between current carry parts and case	
Dielectric strength		1,000 VAC for 1 min between current carry parts and case	
Vibration resistance		Destruction: 10 to 55 Hz, 1.5-mm double amplitude for 2 hours each in X, Y, and Z directions	
Shock resistance		Destruction: 1,000 m/s <sup>2</sup> (approx. 100G) for 10 times each in X, Y, and Z directions	
Degree of protection		IEC IP67	
Weight		Approx. 130 g	Approx. 190 g
Material	Case	SUS303	
	Sensing surface	SUS303	
	Nut	Iron	

# Engineering Data

## Operating Range (Typical)

E2ES-X4D1

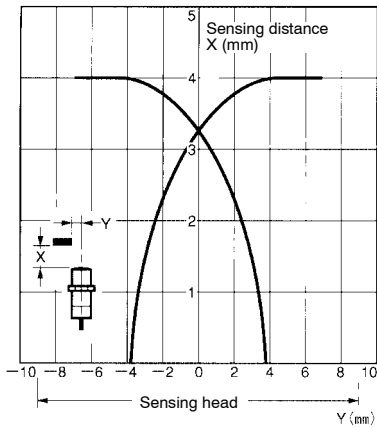

E2ES-X8D1

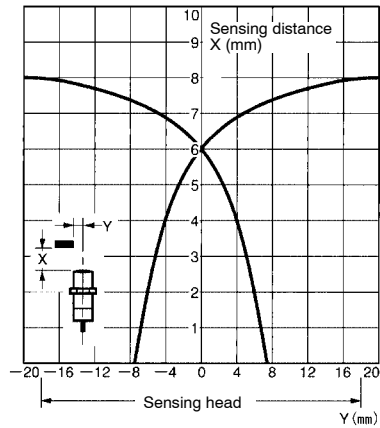

## Sensing Distance vs. Sensing Object (Typical)

E2ES-X4D1

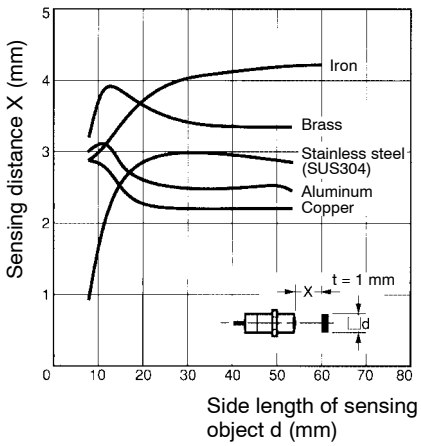

E2ES-X8D1

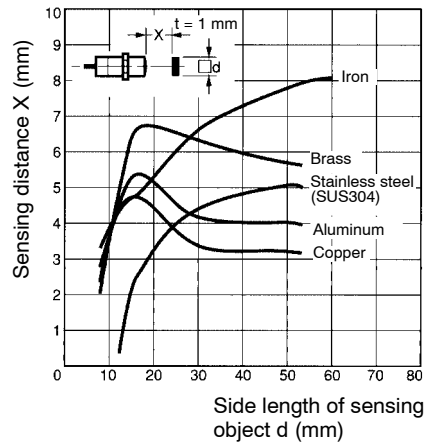

## Residual Output Voltage (Typical)

DC 2-wire Model

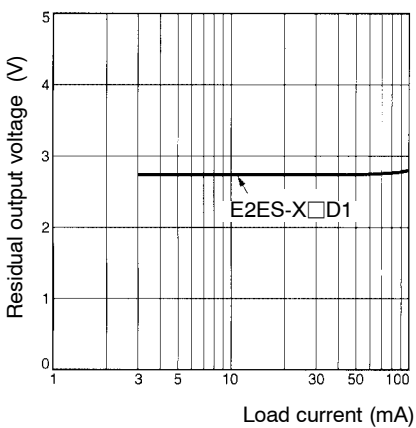

## Leakage Current (Typical)

DC 2-wire Model

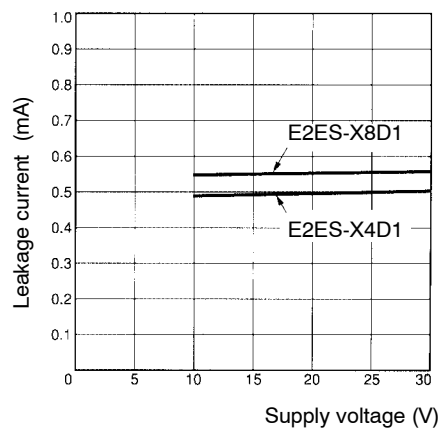

# Operation

## ■ Output Circuit

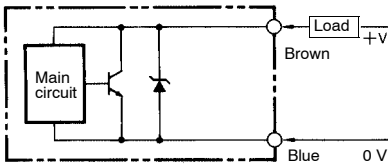

**Note:** The load can be connected to either the +V or 0V side.

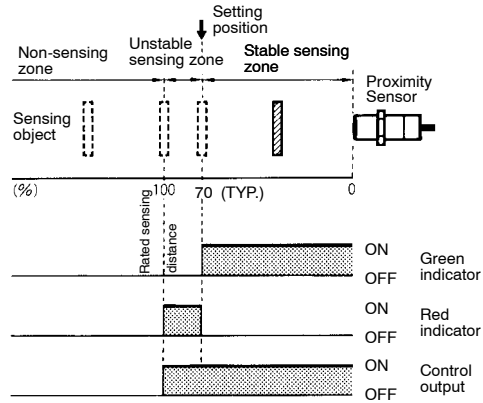

# Dimensions

**Note:** All units are in millimeters unless otherwise indicated.

## E2ES-X4D1

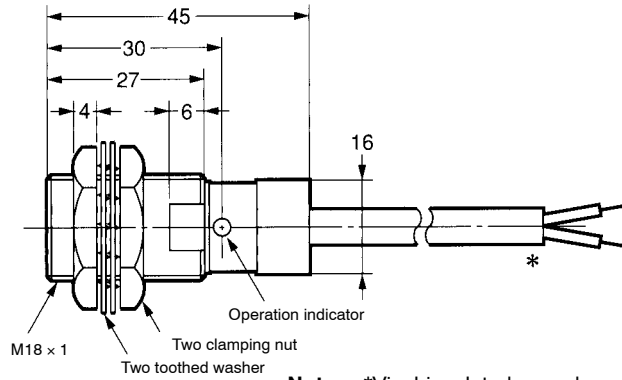
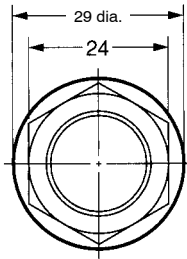
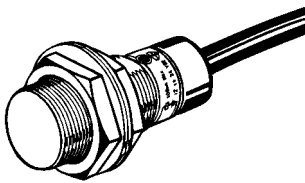

**Note:** \*Vinyl-insulated round cord, 6 dia., 2 cores (0.12 dia. x 45) Standard length: 2 m

## E2ES-X8D1

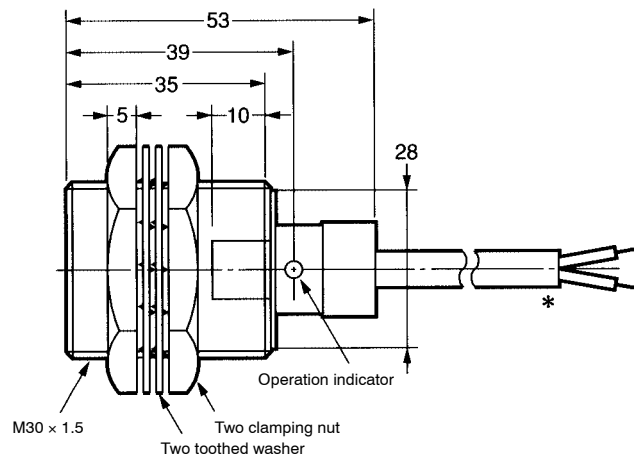
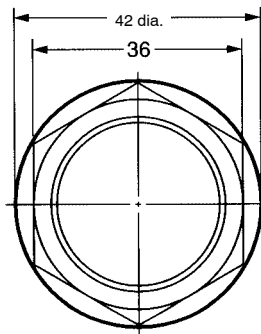
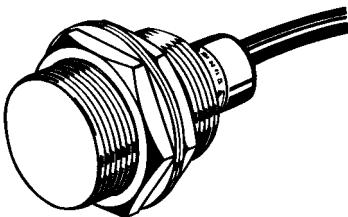

**Note:** \*Vinyl-insulated round cord, 6 dia., 2 cores (0.12 dia. x 45) Standard length: 2 m

## Mounting Holes

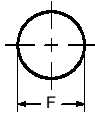

Dimensions	F (mm)
E2ES-X4D1	18.5 dia.
E2ES-X8D1	30.5 dia.

## Precautions

Be sure to abide by the following instructions to ensure the safe operation of the E2ES.

1. Do not use the E2ES in places with flammable, explosive gases.
2. Do not disassemble, repair, or modify the E2ES.
3. Make sure that the power supply terminal polarity is correct.
4. Do not apply any voltage in excess or AC voltage, otherwise the E2ES may be damaged or malfunction.

### Correct Use

#### Mounting

Do not tighten the nut with force exceeding the torque provided in the following table. A toothed washer must be used with the nut.

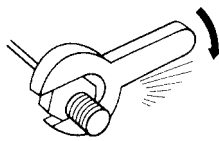

#### Permissible Tightening Torque

Model	Torque
E2ES-X4D1	70 N • m (710 kgf • cm)
E2ES-X8D1	180 N • m (1,800 kgf • cm)

#### Mutual Interference

If more than one E2ES is mounted face to face or in parallel, make sure that the distances between two Units adjacent to each other are the same as or larger than the corresponding values shown in the following table.

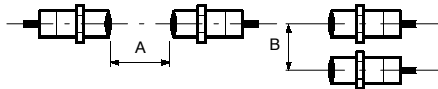

#### Mutual interference (mm)

Item	Model	
	E2ES-X4D1	E2ES-X8D1
A	40	60
B	50	100

#### Effects of Surrounding Metal

When mounting the E2ES within a metal panel, ensure that the corresponding clearances given in either of the following tables are maintained. These clearances vary with whether or not the provided nut is used.

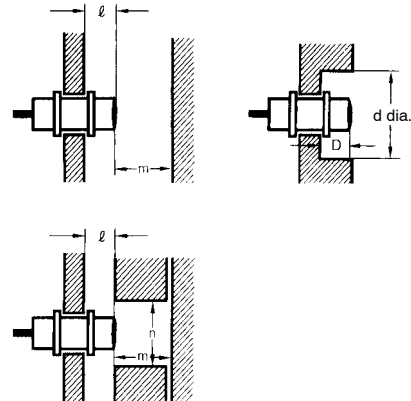

#### Effects of Surrounding Metal

With Provided Nut (mm)

Model	E2ES-X4D1		E2ES-X8D1	
	Iron	Aluminum	Iron	Aluminum
Surrounding metal Item				
$\ell$	7	10	8	10
d	55	40	90	70
D	7	10	8	10
m	16	16	32	32
n	27	54	45	90

Without Provided Nut (mm)

Model	E2ES-X4D1		E2ES-X8D1	
	Iron	Aluminum	Iron	Aluminum
Surrounding metal Item				
$\ell$	10	15	10	20
d	55	40	90	70
D	10	15	10	20
m	16	16	32	32
n	27	54	45	90

**Aluminum and Cast-iron Cutout Chips or Dust**

Usually, aluminum or cast-iron cutout chip or dust on the sensing surface will not be detected except the following cases, when the sensing face needs cleaning.

1. Case 1

- d: Diameter of cutout chip
- D: Diameter of sensing face

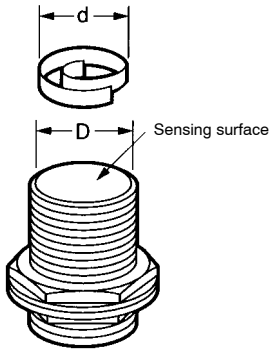

Conditions: The cutout chip is in the middle of the sensing surface and the following is satisfied.  
 $d \geq 2/3D$

Model	Dimensions D (mm)
E2ES-X4D1	16
E2ES-X8D1	28

2. Case 2

Conditions: The cutout dust is pressed onto the sensing surface.

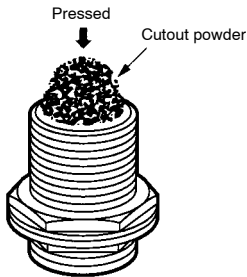



**ALL DIMENSIONS SHOWN ARE IN MILLIMETERS.**

To convert millimeters into inches, multiply by 0.03937. To convert grams into ounces, multiply by 0.03527.

Cat. No. E270-E1-1 **In the interest of product improvement, specifications are subject to change without notice.**

## **OMRON Corporation**

Industrial Sensors Division  
Sensing Devices and Components Division H.Q.  
28th Fl., Crystal Tower Bldg.  
1-2-27, Shiromi, Chuo-ku,  
Osaka 540-6028 Japan  
Phone: (81)6-949-6012 Fax: (81)6-949-6021

Printed in Japan  
0398-2M (0398) a