

- Polymer housing, IP65, and slow-action contacts with positive opening \ominus .
- 2 versions
 - Mechanical lock/Solenoid release
 - Solenoid lock/Mechanical release
- Rotatable operating head provides four possible key entry slots.
- Incorporates an indicator that shows operation status at a glance.
- Double-insulation structure requires no grounding terminals. (with \square mark)
- Three types of Operation Key are available:
 - Horizontal mounting
 - Vertical mounting
 - Angle-adjustable vertical mounting
- Safety Standards
 - Conformity:
 - Machinery Directive
 - Low-voltage Directive
 - EN1088
 - SUVA



■ Approved Standards

Agency	Standard	File No.
TÜV Rheinland	EN60947-5-1	J9650736
BIA	GS-ET-19	Mechanical lock: 9610568 Solenoid lock: 9704054
UL (see note)	UL508, CSA C22.2 No.14	E76675
SUVA	SUVA	Mechanical lock: E6190.d Solenoid lock: E6191.d

Note: CSA C22.2 No. 14 compliance was verified and approved by UL (Marked with UL).

Ordering Information

■ Model Number Legend

Switches

D4DL- \square \square \square \square \square - \square

1 2 3 4 5

1. **Conduit Size (2-conduit)**
 - 1: Pg13.5
 - 2: G $1\frac{1}{2}$
2. **Built-in Switch (with Safety Switch and Lock Monitor Switch Contacts)**
 - C: 1NC/1NO slow-action contacts plus 1NC slow-action contact
 - D: 2NC slow-action contacts plus 1NC slow-action contact
3. **Head Mounting Direction**
 - F: Four mounting directions possible (Front-side mounting at shipping)
4. **Door Lock and Release**
 - A: Mechanical lock / 24-VDC solenoid release (see note)
 - B: Mechanical lock / 110-VAC solenoid release
 - C: Mechanical lock / 230-VAC solenoid release
 - G: 24-VDC solenoid lock / mechanical release (see note)
 - H: 110-VAC solenoid lock / mechanical release
 - J: 230-VAC solenoid lock / mechanical release
5. **Indicator**
 - B: 10 to 115 VAC/VDC (with orange LED indicator)
 - E: 100 to 250 VAC (with orange neon lamp indicator)

Operation Keys

D4DS-K□

1

1. Key Type

- 1: Horizontal mounting
- 2: Vertical mounting
- 3: Horizontal-adjustable vertical mounting
- 5: Vertical/Horizontal-adjustable vertical mounting



■ List of Models

Switches

Solenoid voltage/indicator	Lock and release types	Contact configuration (Slow-action) Approved force-separation NC contact	Connector size	Model	
Solenoid: 24 VDC Orange LED: 10 to 115 VDC/VAC	Mechanical lock Solenoid release	1NC/1NO+1NC	PG13.5	D4DL-1CFA-B*	
			G1/2	D4DL-2CFA-B	
	Solenoid lock Mechanical release	1NC/1NO+1NC	2NC+1NC	PG13.5	D4DL-1DFA-B*
				G1/2	D4DL-2DFA-B
		1NC/1NO+1NC	2NC+1NC	PG13.5	D4DL-1CFG-B*
				G1/2	D4DL-2CFG-B
Solenoid: 110 VAC Orange LED: 10 to 115 VDC/VAC	Mechanical lock Solenoid release	1NC/1NO+1NC	PG13.5	D4DL-1CFB-B	
			G1/2	D4DL-2CFB-B	
	Solenoid lock Mechanical release	1NC/1NO+1NC	2NC+1NC	PG13.5	D4DL-1DFB-B
				G1/2	D4DL-2DFB-B
		1NC/1NO+1NC	2NC+1NC	PG13.5	D4DL-1CFH-B
				G1/2	D4DL-2CFH-B
Solenoid: 230 VAC Orange neon lamp: 100 to 250 VAC	Mechanical lock Solenoid release	1NC/1NO+1NC	PG13.5	D4DL-1CFC-E	
			G1/2	D4DL-2CFC-E	
	Solenoid lock Mechanical release	1NC/1NO+1NC	2NC+1NC	PG13.5	D4DL-1DFC-E
				G1/2	D4DL-2DFC-E
		1NC/1NO+1NC	2NC+1NC	PG13.5	D4DL-1CFJ-E
				G1/2	D4DL-2CFJ-E
1NC/1NO+1NC	2NC+1NC	PG13.5	D4DL-1DFJ-E		
		G1/2	D4DL-2DFJ-E		

Note: Models marked with "*" are recommended

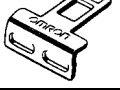
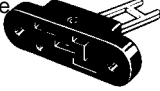
■ Operation Keys (Order Separately)

Type	Model
Horizontal mounting 	D4DS-K1
Vertical mounting 	D4DS-K2
Horizontal-adjustable vertical mounting 	D4DS-K3
Vertical/Horizontal adjustable vertical mounting 	D4DS-K5

Note: The operation keys are the same as for D4DS models.

Specifications

■ Approved Standard Ratings

TÜV (EN60947-5-1)

Item	LED type	Neon lamp type
Utilization category	AC-15	AC-15
Rated operating current (I_e)	6 A	3 A
Rated operating voltage (U_e)	115 V	250 V

Note: Use a 10-A fuse type gI or gG as a short-circuit protection device that conforms to IEC269.

UL/CSA (UL508, CSA C22.2 No. 14)
A300

Rated voltage	Carry current	Current		Volt-amperes	
		Make	Break	Make	Break
120 VAC	10A	60 A	6 A	7,200 VA	720 VA
240 VAC		30 A	3 A		

■ Characteristics

Degree of protection (see note 2)	IP65 (EN60947-5-1)	
Life expectancy (see note 3)	Mechanical: 1,000,000 times min. Electrical: 500,000 times min.	
Operating speed	0.05 to 0.5 m/s	
Operating frequency	30 operations/minute max.	
Rated frequency	50/60 Hz	
Positive opening force (see note 4)	58.84 N min. (EN60947-5-1)	
Positive opening travel (see note 4)	10 mm min. (EN60947-5-1)	
Holding force	500 N min. (GS-ET-19)	
Insulation resistance	100 M Ω min. (at 500 VDC)	
Rated insulation voltage (U_i)	300 V (EN60947-5-1)	
Conventional enclosed thermal current (I_{the})	10 A (EN60947-5-1)	
Rated impulse voltage (U_{imp})	Between terminals of same or different polarity, each terminal and ground, and each terminal and non-current-carrying metal part: 4 kV Between the solenoid and non-current-carrying metal part: 0.8 kV for 24 VDC solenoid, 2.5 kV for 110 VAC solenoid, and 4 kV for 230 VAC solenoid (EN60947-5-1)	
Conditional short-circuit current	100 A (EN60947-5-1)	
Pollution degree (operating environment)	3 (EN60947-5-1)	
Protection against electric shock	Class II (double insulation)	
Switching overvoltage	1,500 V max. (EN60947-5-1)	
Contact resistance	25 m Ω max. (initial value)	
Vibration resistance	Malfuction: 10 to 55 Hz, 0.75-mm single amplitude	
Shock resistance	Mechanical: 1,000 m/s ² min. Malfuction: 300 m/s ² min.	
Ambient temperature	Operating: -10°C to 55°C with no icing	
Ambient humidity	Operating: 95% max.	
Weight	Approx. 340 g (D4DL-1CFA-B)	
Material	Body and actuator flange	Glass-fiber reinforced thermoplast, self-extinguishing
	Actuator	Stainless steel

Note: 1. The above values are initial values.

2. Although the switch box is protected from dust or water penetration, do not use the D4DL in places where foreign material may penetrate through the key hole on the head, otherwise switch damage or malfunctioning may occur.
3. The above mechanical or electrical life is ensured at an ambient temperature of 5°C to 35°C and an ambient humidity of 40% to 70%.
4. These values must be satisfied to ensure safe operation.

Solenoid Characteristics

Item	24 VDC	110 VAC	230 VAC
Rated operating voltage	24 VDC +10%/-15% (100% ED)	110 VAC ±10% (100% ED)	230 VAC ±10% (100% ED)
Current consumption	Approx. 200 mA	Approx. 50 mA	Approx. 30 mA
Insulation	Class F (130°C max.)	Class F (130°C max.)	Class F (130°C max.)

Indicator

Item	LED	Neon lamp
Rated voltage	10 to 115 VAC/VDC	100 to 250 VAC
Current leakage	Approx. 1 mA	Approx. 1.9 mA
Color (LED)	Orange	Orange

Nomenclature

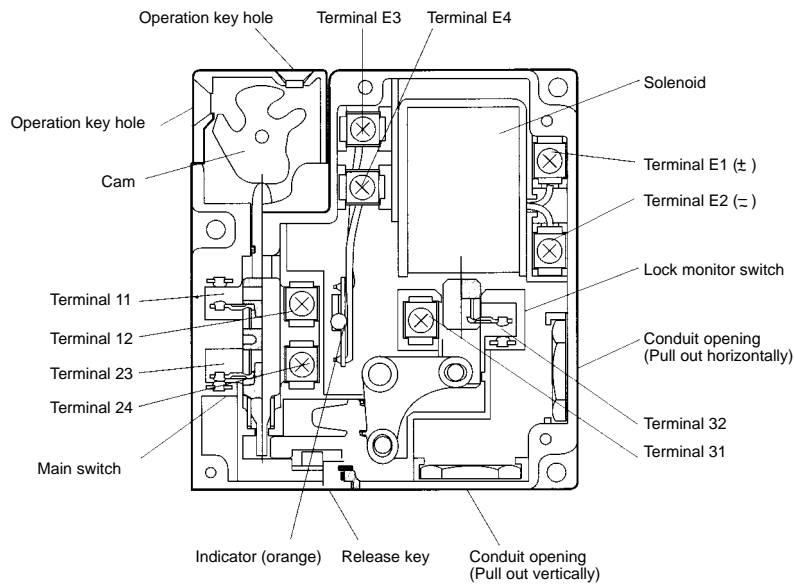

Operation

■ Operation Principles

<p>Mechanical lock model</p>		<ul style="list-style-type: none"> • Door closed • Access to machine is not allowed. • Lock spring locks the door. 	<ul style="list-style-type: none"> • Power to solenoid • Door can be opened.
<p>Solenoid lock model</p>	<ul style="list-style-type: none"> • Door opened • Access to machine is allowed. • Solenoid: OFF • Lock releasing spring releases the door lock. 	<ul style="list-style-type: none"> • Solenoid: OFF • Door can be opened. 	<ul style="list-style-type: none"> • Solenoid: ON • Door locked • Access to the machine is not allowed.

■ **Contacts**

Indicates conditions where the Key is inserted and the lock is applied. Connect the terminals 12 to 31 to conform to BIA GS-ET-19.

Model	Contact	Contact form	Diagram	Remarks
D4DL-□C□□□-□	1NC/1NO + 1NC			Only terminals 11, 12, 31, and 32 have a positive opening mechanism. (→) The terminals 11-12 and 23-24 can be used as opposing poles.
D4DL-□D□□□-□	2NC + 1NC			Terminals 11, 12, 21, 22, 31, and 32 have a positive opening mechanism. (→) The terminals 11-12 and 21-22 can be used as opposing poles.

■ **Indicator**

Internal Circuit Diagram

LED Type (10 to 115 VAC/DC)

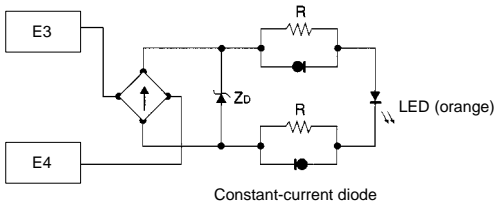

Neon Lamp Type (100 to 250 VAC)

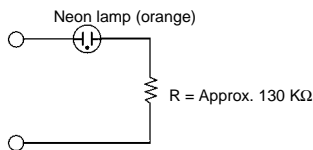

Circuit Connection Example

Circuit is to be connected by user.

- Connect terminals 12 to 31. (To conform to BIA GS-ET-19.)
- Do not connect the indicator in parallel to the contacts. Doing so may allow short-circuit current to flow while the indicator is damaged, causing equipment malfunction.
- The 24-VDC solenoid has polarity. Be sure not to make wiring mistakes.
- In the following connection example, the indicator will be lit when the door is open. (D4DL-1CFA-B)

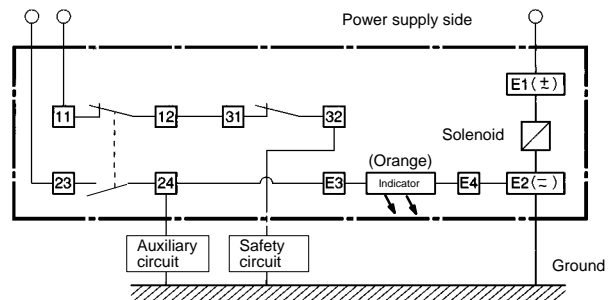

■ Connection Example with OMRON G9S Safety Relay Unit

G9S-321-T□ (24 VDC)+D4DL-□CFA-□/-□CFB-□/-CFC-□ (Mechanical Lock Type)+D4D-□520N

Circuit Diagram

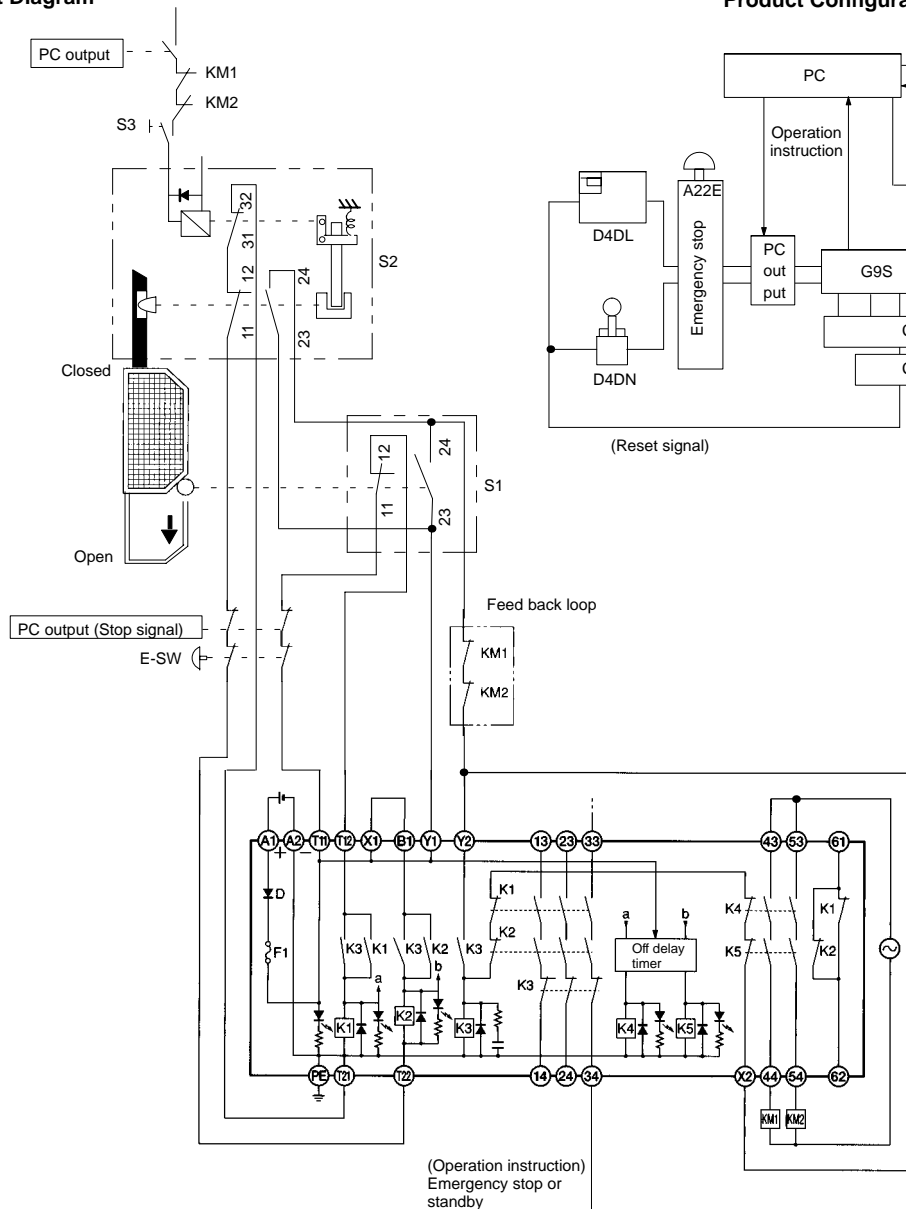

Product Configuration

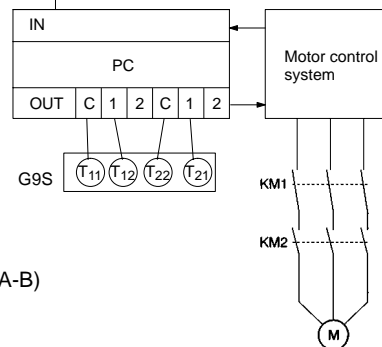
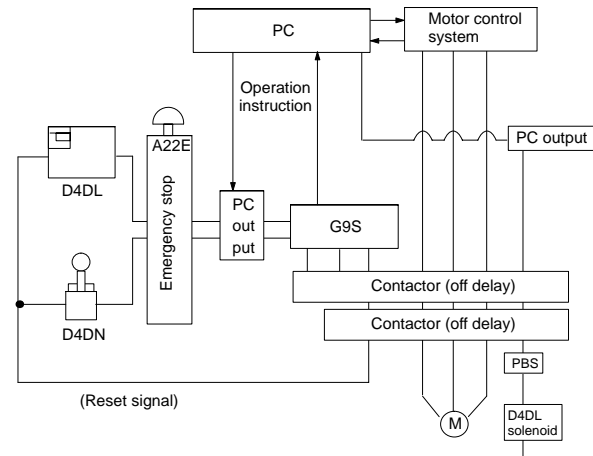

- S1: Safety Switch (D4D-□520N)
- S2: Safety Door Switch with solenoid lock (D4DL-□CFA-B)
- S3: Pushbutton switch for solenoid
- E-SW: Emergency-stop switch (A22E)
- KM1, KM2: Magnet Contactor (LC1-D)
- M: 3-phase motor

G9S-301 (24 VDC)+D4DL-□CFG-□/-□CFH-□/-□CFJ-□ (Solenoid Lock Type)+D4D-□520 N
 Circuit Diagram

Product Configuration

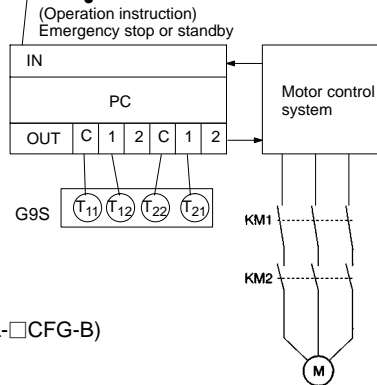
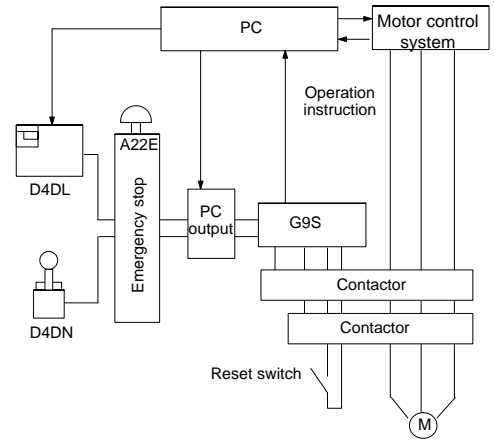
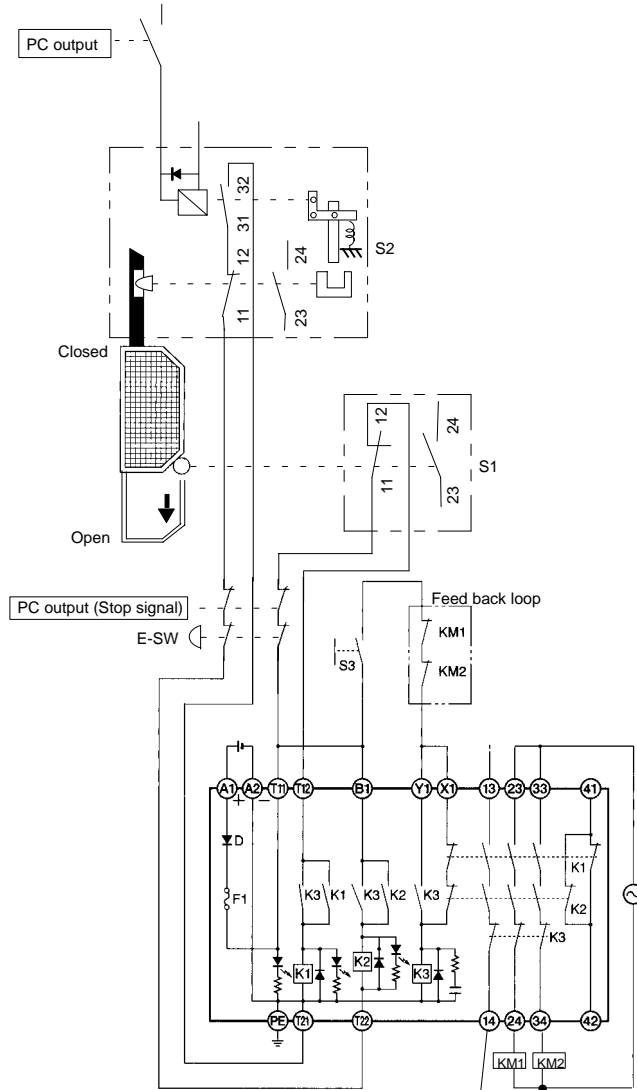

- S1: Safety Switch (D4D-□520N)
- S2: Safety Door Switch with solenoid lock (D4DL-□CFG-B)
- S3: Reset switch
- E-SW: Emergency-stop switch (A22E)
- KM1, KM2: Magnet Contactor (LC1-D)
- M: 3-phase motor

Dimensions

Note: All units are in millimeters unless otherwise indicated.

Switch

D4DL-□□□□-□

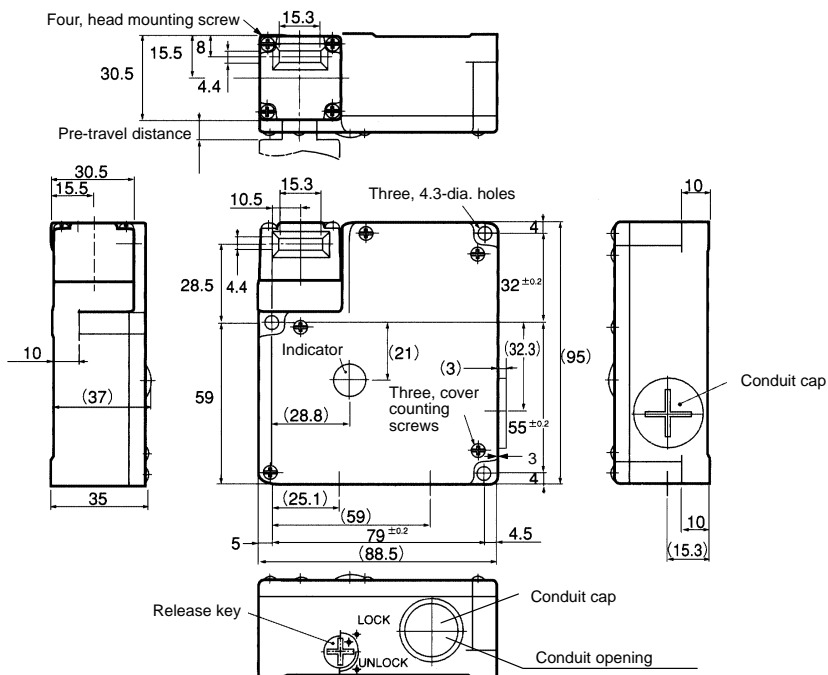
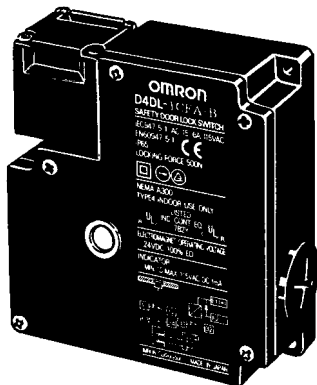

Operating characteristics	Model
Key insertion force	14.71 N max.
Key extraction force	29.42 N max.
Pre-travel distance	9 mm max.
Movement before being locked	3 mm min.

Operation Key

Note: Each dimension has a tolerance of ±0.4 mm unless otherwise specified.

D4DS-K1
Horizontal Mounting

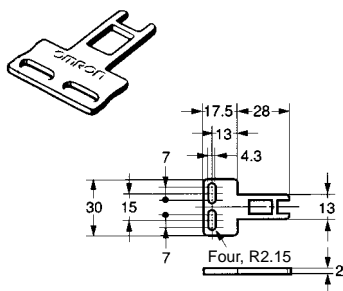

D4DS-K2
Vertical Mounting

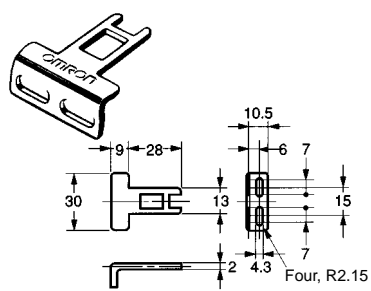

D4DS-K3
Horizontal-adjustable Vertical Mounting

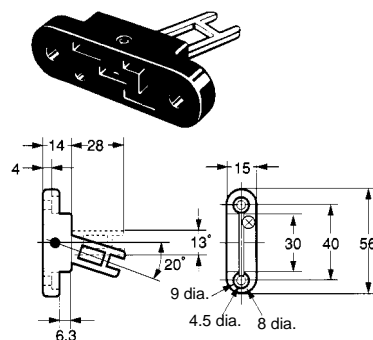

D4DS-K5
Horizontal/Vertical-adjustable Vertical Mounting

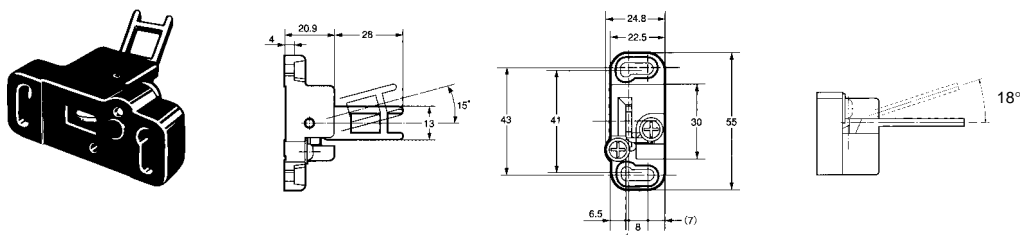

Operation Key Inserted
D4DL + D4DS-K1

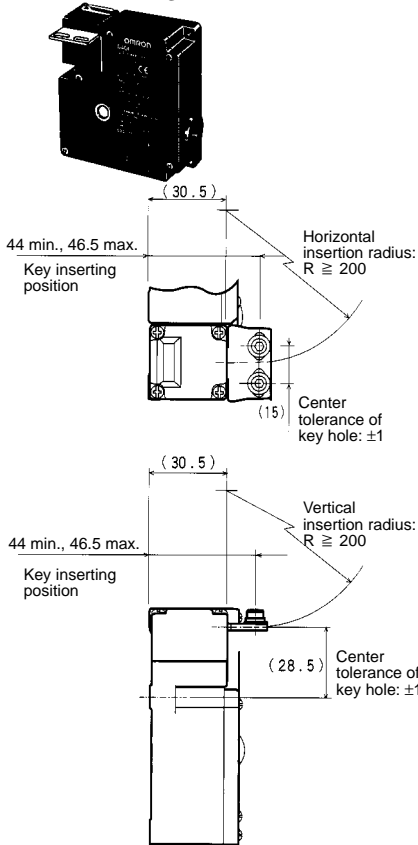

D4DL + D4DS-K2

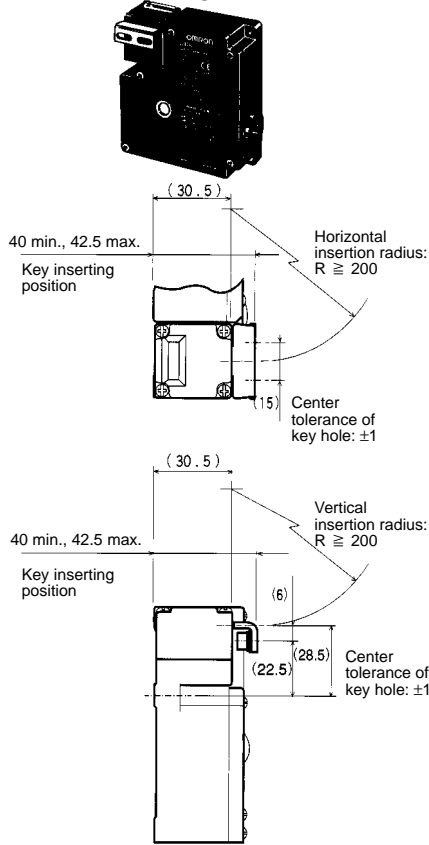

D4DL + D4DS-K3

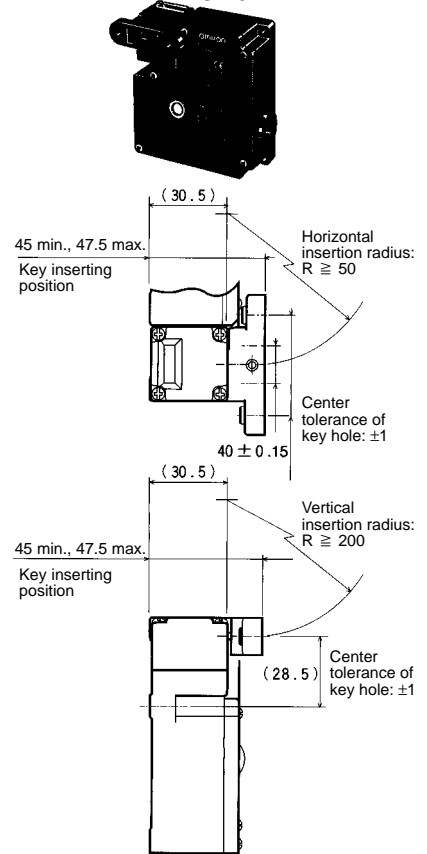

D4DL + D4DS-K5

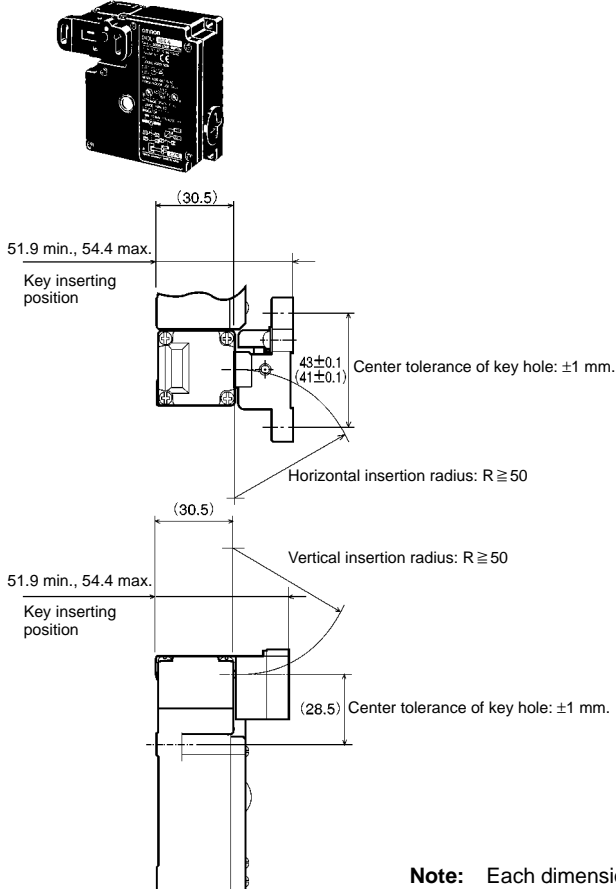

Note: Each dimension has a tolerance of ± 0.4 mm unless otherwise specified.

Precautions



CAUTION

Do not dismount the operation key from the door intentionally and insert it to the switch with the door open. Machine may start operating and injury or death may be caused.

Do not use metal connectors or conduits with this switch. Rigid connectors and conduits may damage the switch. The broken conduit hole may cause an electrical shock hazard.

After-changing the release key to the UNLOCK position or inserting the operation key, change the head direction. Otherwise, the switch may malfunction and injuries may occur due to mis-operation of the device.

NOTICE

Install the operation key so that it will not hit the operator when the door is open.

If the D4DL is applied to an emergency stop circuit or safety circuit for prevention of injury, use the NC contact, which incorporates a positive opening mechanism, and make sure that the D4DL operates in positive mode. Furthermore, secure the D4DL with screws or equivalent parts that are tightened in a single direction so that the D4DL or operation key cannot be easily removed or provide a protection cover to the D4DL and post a warning label near the D4DL.

To protect the D4DL from damage due to short-circuits, connect the D4DL in parallel to a fuse that has a breaking current 1.5 to 2 times the rated current of the D4DL. If the D4DL is used under EN-approved rating conditions, use a 10-A fuse, type gI or gG conforming to IEC 269.

Do not supply power to the D4DL while wiring the D4DL.

In order to prevent the D4DL from burning due to overvoltage, insertion of a protection fuse into the solenoid circuits is recommended. Do not use the D4DL in locations subject to explosive or flammable gases.

Make sure that the load current does not exceed the rated current and that the load terminals are wired correctly.

Pay utmost attention to correctly wire each terminal.

After mounting and adjusting the D4DL, make sure that the D4DL operates properly.

If the D4DL is imposed with force exceeding the lock strength, the D4DL may break and the equipment may continue operating.

Do not drop or disassemble the D4DL.

Release Key

The release key is used to unlock the D4DL in case of emergency or if the power supply to the D4DL fails.

Use an appropriate tool to set the release key to UNLOCK so that the lock will be released and the door can be opened.

The release key is set at the UNLOCK position. Set the release key to the LOCK position before use.

Mechanical Lock Type

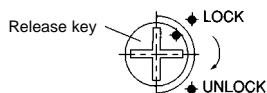

The release key applied to the door of a machine room ensures the safety of people adjusting the equipment in the machine room. If the release key is set to UNLOCK, the door will not be locked when the door is closed and no power will be supplied to the equipment.

Do not use the release key to start or stop machines.

To prevent the release key from being used carelessly by unauthorized people, set the release key of the D4DL in normal operation to UNLOCK and seal the release key with seal wax.

Mounting

Be sure to mount the D4DL with a stopper as shown in the following illustration. Do not use the D4DL Switch as a stopper.

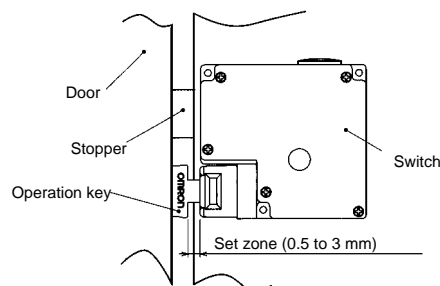

Solenoid Lock Type

The solenoid lock locks the door only when power is supplied to the solenoid. Therefore, the door will be unlocked if the power supply to the solenoid fails. Therefore, do not use the solenoid lock type for machines that may be operating and dangerous even after the machine stops operating because of inertia.

Life Expectancy

The life of the D4DL will vary with the switching conditions. Before applying the D4DL, test the D4DL under actual operating conditions and be sure to use the D4DL in actual operation within switching times that will not lower the performance of the D4DL.

Operating Environment

The D4DL is for indoor use only. Do not use the D4DL outdoors. Otherwise, the D4DL may malfunction.

Do not use the D4DL in the following locations:

- Locations with severe changes in temperature
- Locations with excessive humidity that may cause condensation
- Locations with excessive vibration
- Locations where metal dust, oil, or chemical may be sprayed onto the D4DL

Operation Key

Be sure to use the dedicated Operation Key only.

Do not operate the D4DL with anything other than the dedicated Operation Key. Otherwise, the safety of the system may not be maintained.

Do not impose excessive force on the Operation Key inserted into the D4DL or drop the D4DL with the Operation Key inserted. Otherwise, the Operation Key may be deformed or broken.

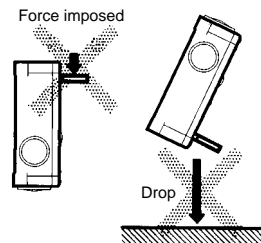

Secure the Operation Key with a one-way screw, or an equivalent, so that the Operation Key cannot be easily removed.

Locking the Door

The D4DL may eventually break if the door opens accidentally due to the weight of the door, the vibration of the machine, or the bouncing of the door against the rubber bumper.

Furthermore, the door may not be unlocked if force is imposed on the operation key.

Do not use the casing of the D4DL as a locking mechanism for the door in such cases and be sure to prepare a special lock within the lock range of the D4DL (i.e., 0.5 to 3 mm).

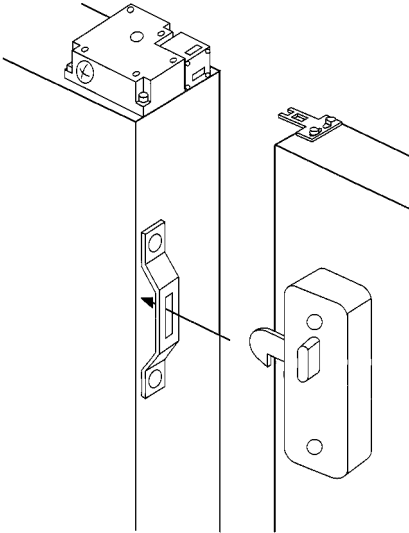

Mounting

Refer to page 338 for the mounting dimensions of the Operation Key. Be sure that the Operation Key can be inserted properly with a tolerance of ± 1 mm in the upward, downward, left, or right direction, otherwise the D4DL may be damaged.

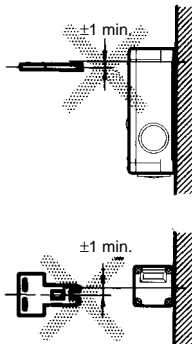

Tightening Torque

Be sure to tighten each screw of the D4DL properly, otherwise the D4DL may malfunction.

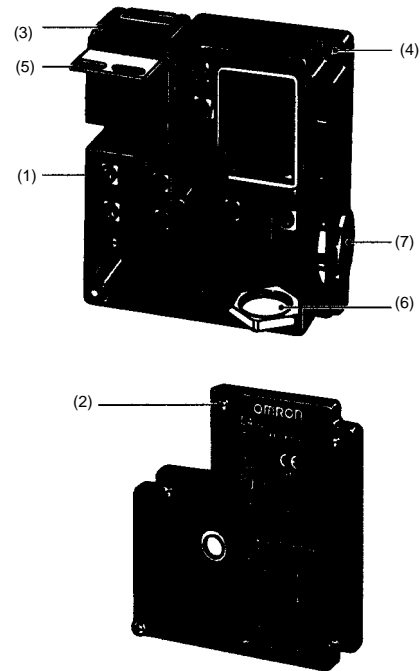

	Type	Proper tightening torque
(1)	Terminal screw (M3.5)	0.59 to 0.78 N • m
(2)	Cover mounting screw	0.78 to 0.88 N • m
(3)	Head mounting screw	0.78 to 0.88 N • m
(4)	Body mounting screw (M4) (see note)	0.49 to 0.69 N • m
(5)	Operation Key mounting screw	2.35 to 2.75 N • m
(6)	Connector at conduit opening	1.77 to 2.16 N • m
(7)	Cap screw	1.27 to 1.67 N • m

Note: Tighten each screw together with a washer to the specified torque.

Mounting

Be sure that the D4DL operates properly after mounting and adjusting the D4DL.

Use M4 screws (one-way screws, etc.) and washers to mount the D4DL and Operation Key securely.

Switch Mounting Holes

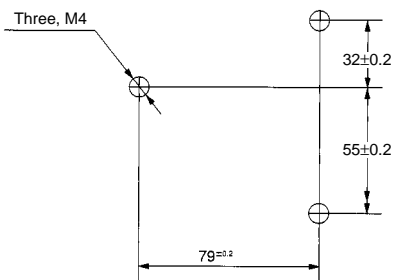

- Horizontal/Vertical-adjustable Vertical Mounting
D4DS-K5

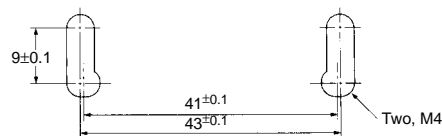

Operation Key Mounting Holes

- Horizontal/Vertical Mounting
D4DSK1/D4DS-K2

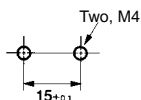

- Horizontal-adjustable Vertical Mounting
D4DS-K3

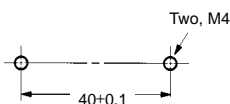

Head Direction

By removing the four screws of the head, the mounting direction of the head can be changed. The head can be mounted in four directions.

Wiring

Do not connect lead wires directly to the terminals. Be sure to connect the lead wires through insulation tubes and crimp terminals. The lead wires must be an AWG20 to AWG18 type (i.e., 0.5 to 10 mm² thick).

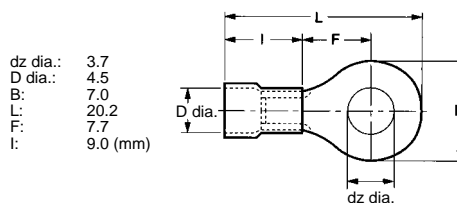

ALL DIMENSIONS SHOWN ARE IN MILLIMETERS.
To convert millimeters into inches, multiply by 0.03937. To convert grams into ounces, multiply by 0.03527.