

Compact limit switch in metal housing

# D4C

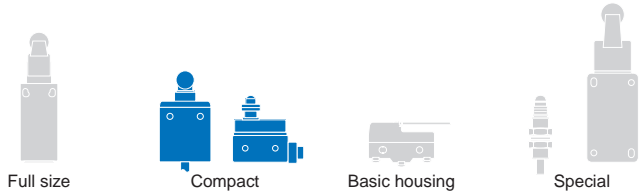







The 16 mm flat and compact size make the D4C range of limit switches very popular for all standard applications but especially where mounting space is limited or protruding housings may interfere with machine operation. The triple sealed construction, the rugged metal housing, the precisely manufactured movable parts and the optional protective features ensure longest operational life in standard, cold, outdoor or oily environments.

- 16 mm flat compact size
- rugged metal housing
- models with M12 connector or oil resistant VCTF cable



## Ordering Information

Actuator type	Load range (VDC) <sup>†1</sup>		Operation LED indicator		Connection method				Order code	
	5 mW to 0.8 W (micro load)	0.8 W to 60 W max								
			No	Yes						
Plunger 	-	■	■	-		■		*2	D4CC-3001	
			-	■		■			3 m	D4C-1201
	■	-							3 m	D4CC-4001
									3 m	D4C-3201
Sealed plunger 	-	■	■	-		■		*2	D4CC-6201	
			-	■		■			3 m	D4CC-3031
	■	-							3 m	D4C-1231
									3 m	D4CC-4031
Plunger with M14 mounting 	-	■	■	-		■		*2	D4CC-3231	
			-	■		■			3 m	D4C-6231
	■	-							3 m	D4CC-3041
									3 m	D4C-1241
Roller plunger 	-	■	■	-		■		*2	D4CC-4041	
			-	■		■			3 m	D4C-3241
	■	-							3 m	D4CC-6241
									3 m	D4C-3002
Sealed roller plunger 	-	■	■	-		■		*2	D4C-1202	
			-	■		■			3 m	D4CC-4002
	■	-							3 m	D4C-3202
									3 m	D4CC-6202
Sealed roller plunger 	-	■	■	-		■		*2	D4CC-3032	
			-	■		■			3 m	D4C-1232
	■	-							3 m	D4CC-4032
									3 m	D4C-3232
Sealed roller plunger 	-	■	■	-		■		*2	D4CC-6232	
			-	■		■			3 m	D4C-3232
	■	-							3 m	D4CC-3032
									3 m	D4C-6232

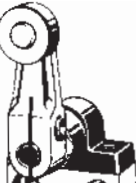
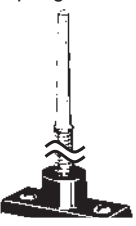



Actuator type	Load range (VDC) <sup>*1</sup>		Operation LED indicator		Connection method				Order code
	5 mW to 0.8 W (micro load)	0.8 W to 60 W max	No	Yes					
Roller plunger with M14 mounting 	-	■	■	-		■	3 m	*2	D4CC-3042
	■	-	-	■		■	3 m		D4C-1242
									D4CC-4042
									D4C-3242
									D4C-6242
Crossroller plunger 	-	■	■	-		■	3 m		D4CC-3003
	■	-	-	■		■	3 m		D4C-1203
									D4CC-4003
									D4C-3203
									D4C-6203
Sealed crossroller plunger 	-	■	■	-		■	3 m		D4CC-3033
	■	-	-	■		■	3 m		D4C-1233
									D4CC-4033
									D4C-3233
									D4C-6233
Crossroller plunger with M14 mounting 	-	■	■	-		■	3 m		D4CC-3043
	■	-	-	■		■	3 m		D4C-1243
									D4CC-4043
									D4C-3243
									D4C-6243
Roller lever 	-	■	■	-		■	3 m		D4CC-3024
	■	-	-	■		■	3 m		D4C-1220
									D4CC-4024
									D4C-3220
									D4C-6220
Coil spring 	-	■	■	-		■	3 m		D4CC-3050
	■	-	-	■		■	3 m		D4C-1250
									D4CC-4050
									D4C-3250
									D4C-6250

\*1 See specifications for details on max. current per rated voltage and load type

\*2 Pre-wired models with 30 cm PVC cable and M12 plug (pigtail) are available. Contact your OMRON representative.

Accessories

Cable connectors

Size	Shape	Type	Features	Material		Order code	
				Nut	Cable		
M12 		General purpose (screw)	3 wire (LED optionally)	Brass (CuZn)	PVC 2 m	XS2F-M12PVC3S2M	XS2F-M12PVC3A2M
					PUR 2 m	XS2F-M12PUR3S2M	XS2F-M12PUR3A2M
			4 wire		PVC 2 m	XS2F-M12PVC4S2M	XS2F-M12PVC4A2M
					PUR 2 m	XS2F-M12PUR4S2M	XS2F-M12PUR4A2M

Additional or spare actuators (Order separately)

Actuator type	Order code
Plunger	D4C-0001
Sealed plunger	D4C-0031
Plunger with M14 mounting	D4C-0041
Roller plunger	D4C-0002
Sealed roller plunger	D4C-0032
Roller plunger with M14 mounting	D4C-0042

Actuator type	Order code
Crossroller plunger	D4C-0003
Sealed crossroller plunger	D4C-0033
Crossroller plunger with M14 mounting	D4C-0043
Roller level	D4C-0020
Coil spring	D4C-0050

## Model number legend

D4C□-□□□-□  
 1 2 3 4 5

### 1 Connection method

- Nothing: cable types
- C: M12 connector types

### 2 Operation LED indicator, rated current and voltage

- 1: no indicator, 2 A 250 VAC/2 A 30 VDC (D4C- cable type only)
  - 3: LED indicator, 2 A 30 VDC (D4C-cable type)  
 No indicator, 1 A 30 VDC (D4CC- M12 connector type)
  - 4: LED indicator, 1 A 30 VDC (D4CC- M12 connector type only)
  - 6: LED indicator 0.1 A 30 VDC (D4C- cable type only)
- VAC only rated types with LED indicator are available. Contact your OMRON representative.

### 3 Cable specification and length

- Nothing: M12 connector models
- 2: 3 m oil resistant VCTF cable (other cable lengths are available)

### 4 Actuator

- 01: Plunger
- 02: Roller plunger
- 03: Crossroller plunger
- 20: Roller lever (for D4C)
- 24: Roller lever (for D4CC)
- 31: Sealed plunger
- 32: Sealed roller plunger
- 33: Sealed crossroller plunger
- 41: Plunger with M14 mounting
- 42: Roller plunger with M14 mounting
- 43: Crossroller plunger with M14 mounting
- 50: Coil spring

Additional actuators (contact your OMRON representative for details and availability)

- 10: Bevel plunger
- 24: High sensitivity roller lever
- 27: Variable roller lever
- 29: Variable rod lever
- 60: Center roller lever

### 5 Specials (contact your OMRON representative for details and availability)

- C: Cold resistant models down to -40°C
- M: Models with oil drain hole (plunger types)
- P: Enhanced outdoor lifetime models (silicone rubber seal, higher grade stainless steel)
- B: Models with LED indicator where indicator turns ON when actuator is operated (standard is indicator turns OFF when actuator is operated)
- M1J/ -1EJ: Pre-wired models with M12 plug, 2 wires (NO) or 3 wires (NO+NC) connected and 0.3 m, 0.5 m or 1 m VCTF cable
- (cUL) Models with UL approval (UL508: file nr E76675) and CSA approval (CSA C22.2 No. 14: file nr LR45746)

Specifications

Voltage and current rating

Model	Rated voltage	Rated current <sup>*1</sup>	Non-inductive load				Inductive load				Inrush current		Applicable load range (5 to 30 VDC)	
			Resistive load		Lamp load		Inductive load		Motor load		NC	NO		
			NC	NO	NC	NO	NC	NO	NC	NO				
D4C-1□□□	125 VAC		5 A	5 A	1.5 A	0.7 A	3 A	3 A	2.5 A	1.3 A	20 A max.	10 A max.	-	
	250 VAC	2 A	5 A	5 A	1 A	0.5 A	2 A	2 A	1.5 A	0.8 A				0.8 W to 60 W
	8 VDC		5 A	5 A	2 A	2 A	5 A	4 A	3 A	3 A				
	14 VDC		5 A	5 A	2 A	2 A	4 A	4 A	3 A	3 A				
	30 VDC	2 A	4 A	4 A	2 A	2 A	3 A	3 A	3 A	3 A			-	
	125 VDC		0.4 A	0.4 A	0.05 A	0.05 A	0.4 A	0.4 A	0.05 A	0.05 A				
	250 VDC		0.2 A	0.2 A	0.03 A	0.03 A	0.2 A	0.2 A	0.03 A	0.03 A				
D4C-3□□□	30 VDC	2 A	4 A	4 A	2 A	2 A	3 A	3 A	3 A	3 A			0.8 W to 60 W	
D4CC-3□□□ D4CC-4□□□	30 VDC	1 A	1 A	1 A	1 A	1 A	1 A	1 A	1 A	1 A	5 A max.	2.5 A max.	0.8 W to 30 W	
D4C-6□□□	30 VDC	0.1 A	0.1 A	0.1 A	-	-	-	-	-	-	20 A max.	10 A max.	5 mW to 0.8 W	

\*1 For D4C- cable types these ratings are certified by TÜV Rheinland according to EN60947-5-1 (file no R9451333).

General specifications

		D4C- (cable types)	D4CC- (connector types)
Durability <sup>*1</sup>	Mechanical	10,000,000 operations min	
	Electrical	200,000 operations min	
Operating speed	Plunger	0.1 mm/s to 0.5 m/s	
	Roller lever	1 mm/s to 1 m/s	
Operating frequency	Mechanical	120 operations/min	
	Electrical	30 operations/min	
Rated frequency	50/60 Hz		
Insulation resistance	100 MΩ min (at 500 VDC)		
LED indicator	D4C-3_, D4C-6_, D4CC-4_: Operation indicator (red) Operation indicator turns OFF when the switch operates. <sup>*2</sup>		
Contact resistance (initial)	300 mΩ max		100 mΩ max
Dielectric strength	1,000 VAC, 50/60 Hz for 1 min between terminals of the same polarity 1,500 VAC, 50/60 Hz for 1 min between current-carrying metal part and ground, and between each terminal and non-current-carrying metal part		
Vibration resistance	Malfunction: 10 to 55 Hz, 1.5 mm double amplitude <sup>*3</sup>		
Shock resistance	Destruction	1,000 m/s <sup>2</sup> min	
	Malfunction	500 m/s <sup>2</sup> min	
Ambient temperature	Operating	-10°C to 70°C (with no icing)	
Ambient humidity	Operating	95% max.	
Degree of protection	IEC 60529: IP67		
Weight	Approx. 360 g		Approx. 120 g (for D4CC-1002)

\*1 Values are acquired at 5° to 35°C operating temperature, 40% to 70% operating humidity

\*2 Models where operation indicator turns ON when the switch operates are available by adding '-B' to the order code. Contact your OMRON representative for availability.

\*3 Not valid for coil spring models D4C-\_-50

Additional specifications after EN60947-5-1 (D4C- cable types only)

Rated insulation voltage	300 V
Switching overvoltage	1,000 VAC, 300 VDC max
Short circuit protective device	10 A fuse type gG (IEC269)
Conditional short circuit current	100 A
Conventional enclosed thermal current	5 A, 4 A, 0.5 A
Protection against electrical shock	Class I (with grounding wire)

Operating characteristics

	□-□01	□-□02	□-□03	□-□41	□-□42	□-□43	□-□31	□-□32	□-□33	□-□20	□-□50
Operating force (OF)	11.77 N max						17.65 N max			5.69 N max	1.47 N max
Release force (RF)	4.41 N min									1.47 N max	-
Pre-travel (PT)	1.8 mm max									25°	15°
Over travel (OT)	3 mm min									40°	-
Movement differential (MD)	0.2 mm max									3°	-
Operating position (OP)	15.7 ±1 mm	28.5±1 mm		31.2 ±1 mm	36.8±1 mm		24.9 ±1 mm	34.3±1 mm		-	-

Output circuit diagrams

Without indicator

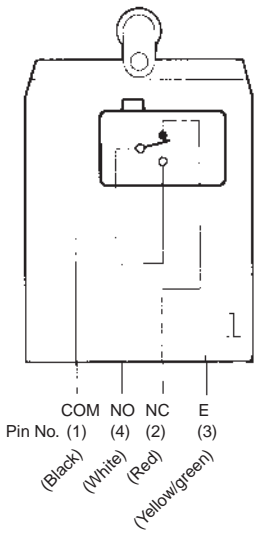

With indicator

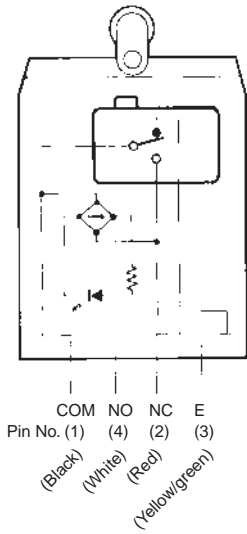

Connector pin arrangement

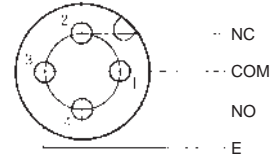

**Note:** Connection of LED indicator circuit to NO or NC depends on selected model:  
 - LED turns OFF when operated (standard)  
 - LED turns ON when operated (-B models)

Nomenclature

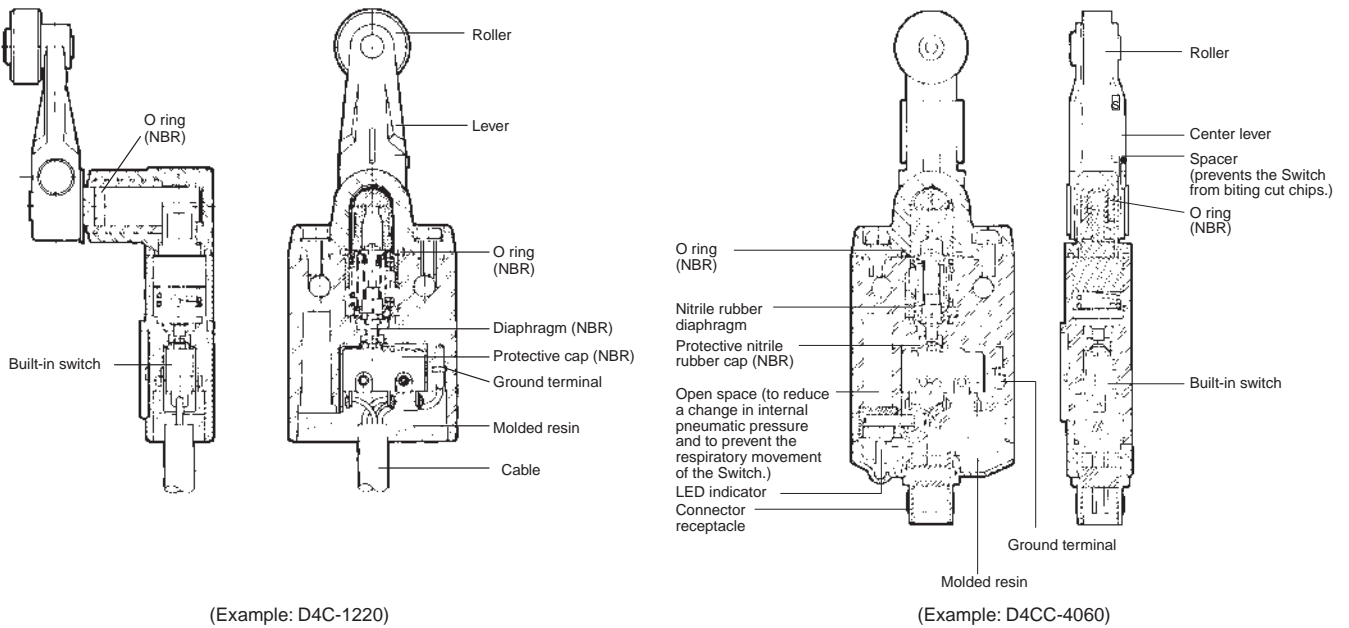

Dimensions

Pin plunger

D4C-□□01  
D4CC-□□01

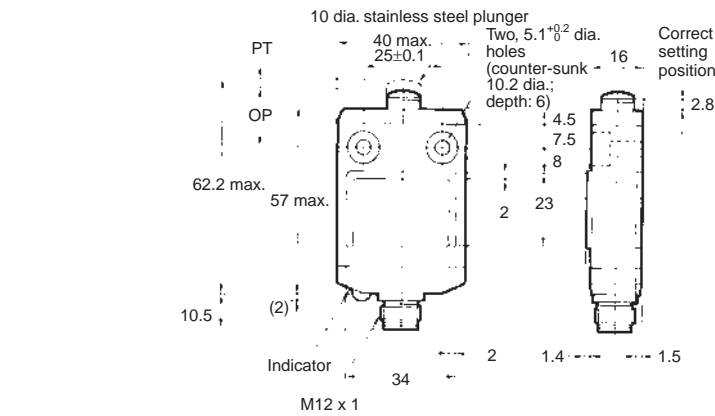
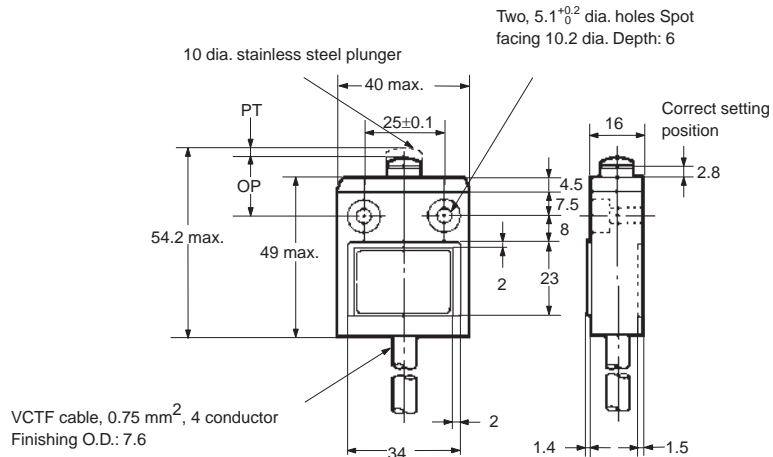
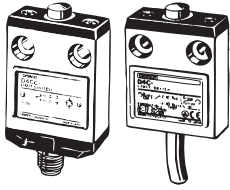

Roller plunger

D4C-□□02  
D4CC-□□02

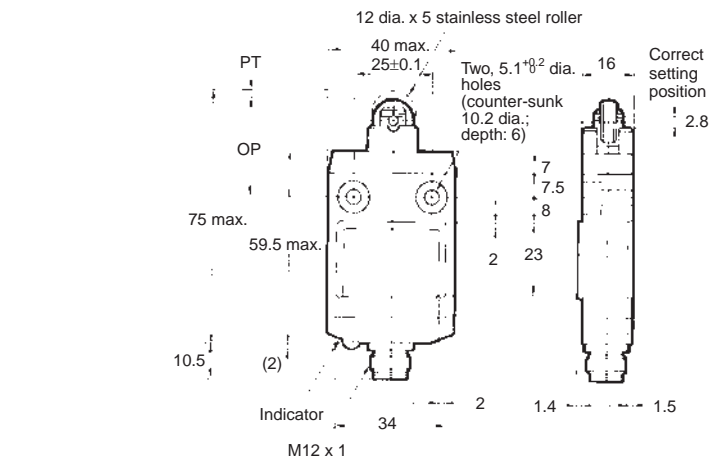
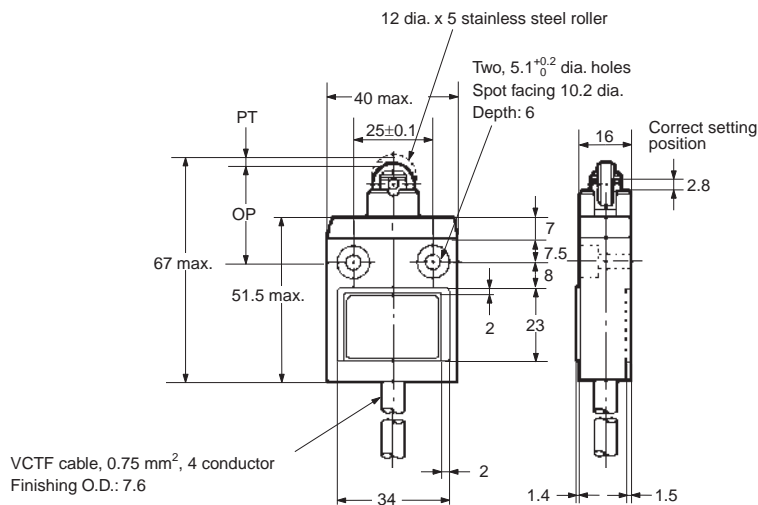
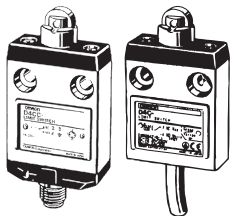

Crossroller plunger

D4C-□□03  
D4CC-□□03

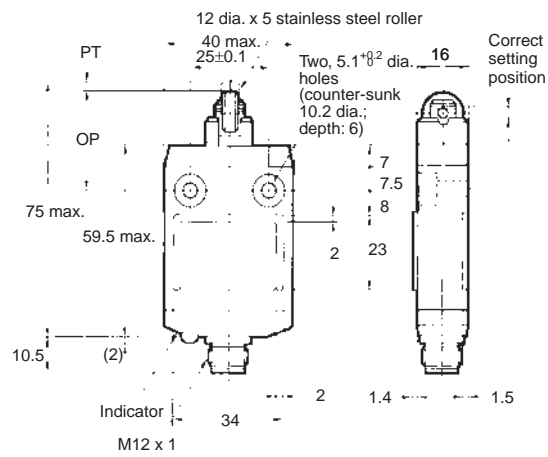
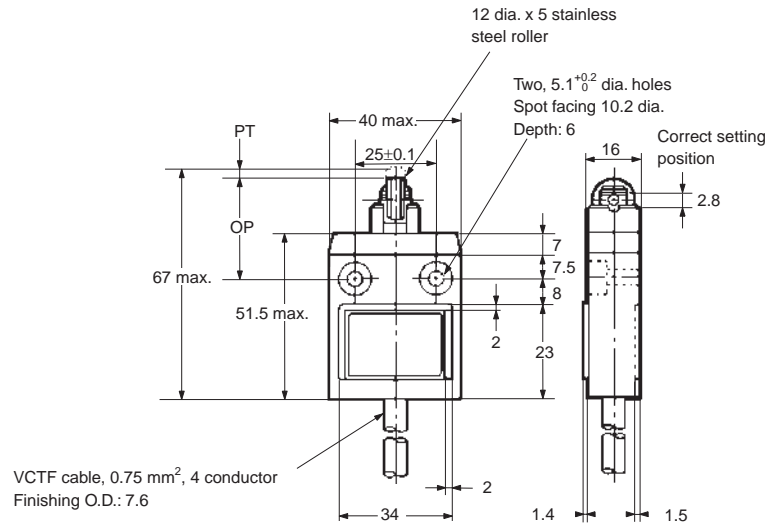
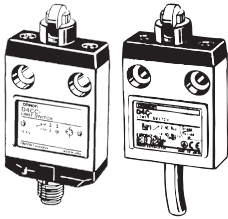

Roller lever

D4C-□□20  
D4CC-□□020

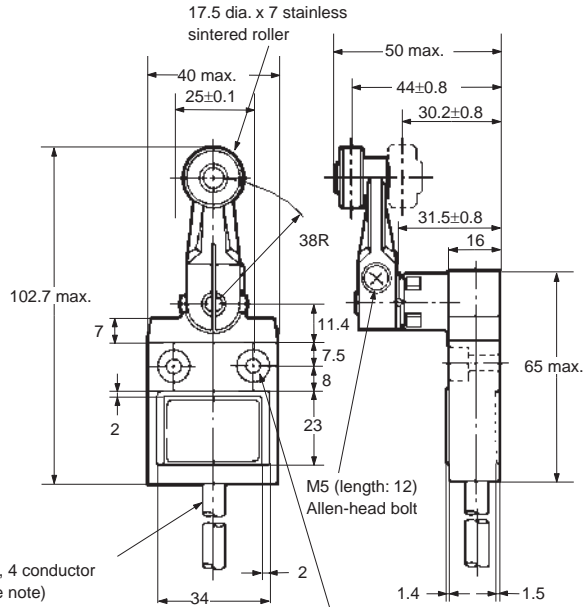
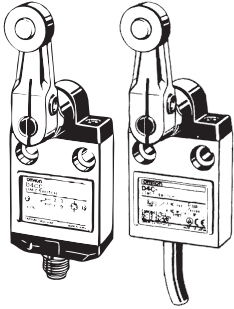

VCTF cable, 0.75 mm<sup>2</sup>, 4 conductor  
Finishing O.D.: 7.6 (see note)

**Note:** S-FLEX VCTF Cables are used for weather-resistant models (D4C-P).

Two, 5.1<sup>+0.2</sup> dia. holes  
Spot facing 10.2 dia.  
Depth: 6

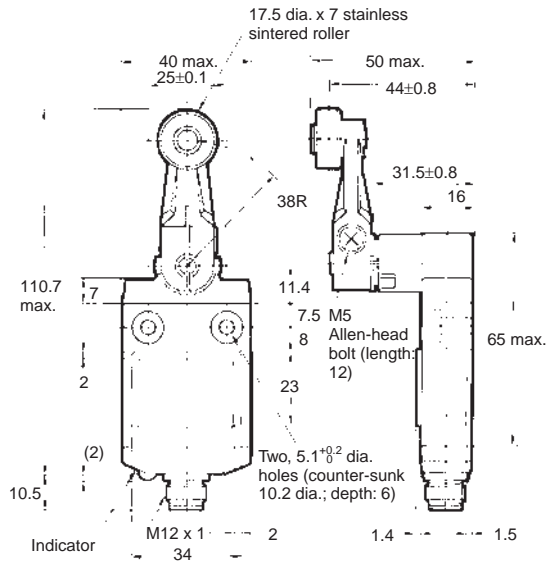

17.5 dia. x 7 stainless  
sintered roller

Two, 5.1<sup>+0.2</sup> dia.  
holes (counter-sunk  
10.2 dia.; depth: 6)



Sealed plunger

D4C-□□31

D4CC-□□31

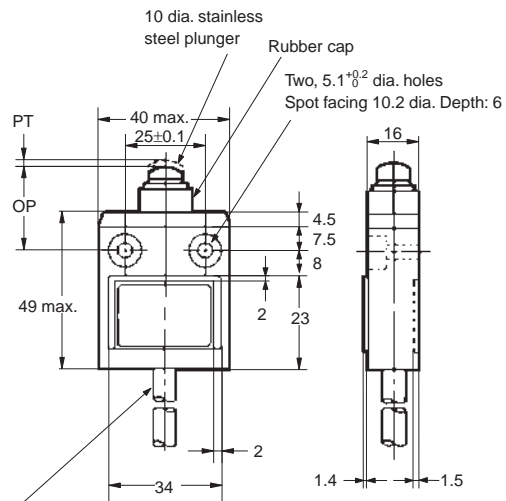
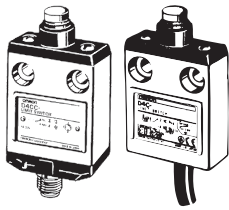

VCTF cable, 0.75 mm<sup>2</sup>, 4 conductor  
Finishing O.D.: 7.6

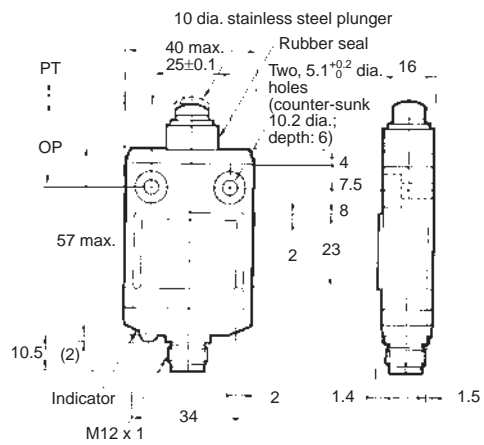

Sealed roller plunger

D4C-□□32  
D4CC-□□32

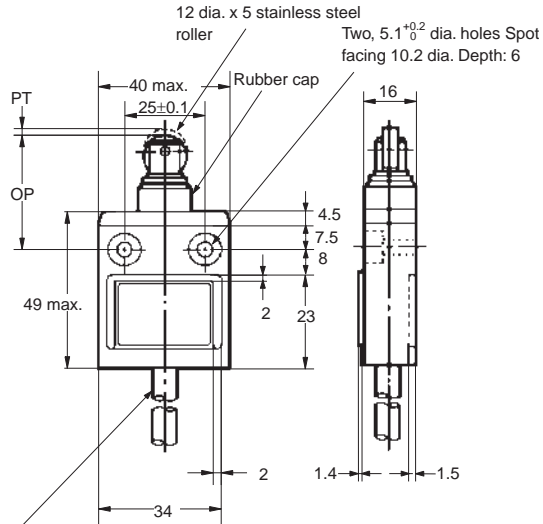
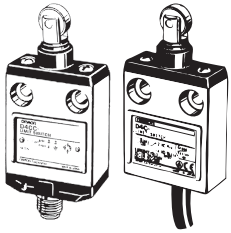

VCTF cable, 0.75 mm<sup>2</sup>, 4 conductor  
Finishing O.D.: 7.6

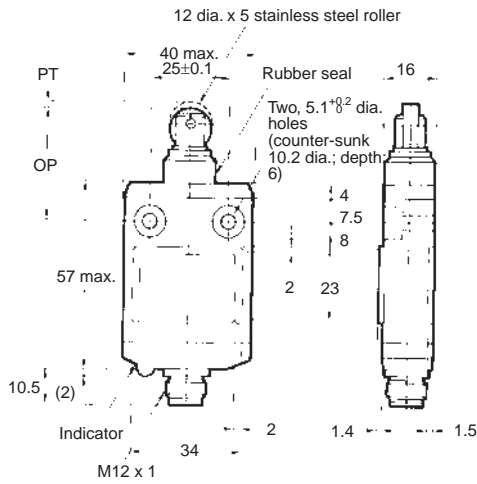

Sealed crossroller plunger

D4C-□□33  
D4CC-□□33

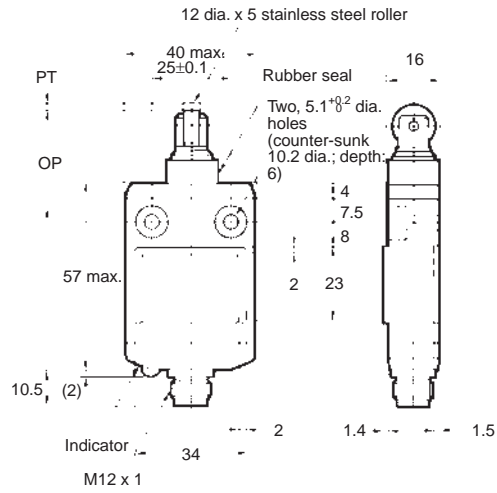
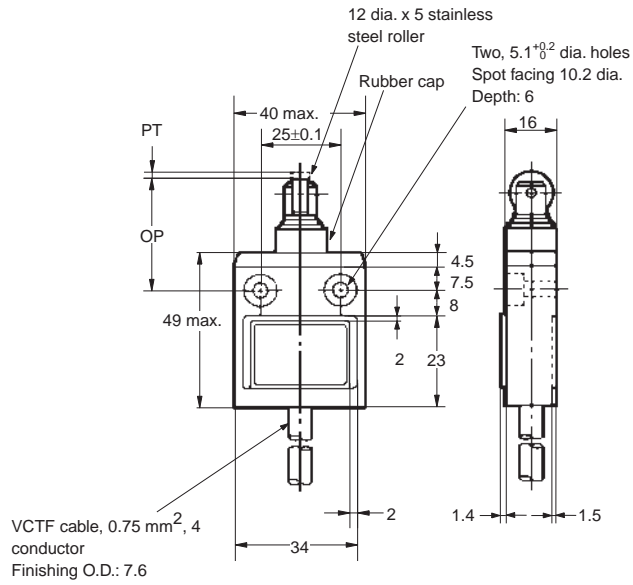
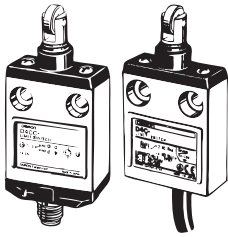

Pin plunger with M14 mounting

D4C-□□41  
D4CC-□□41

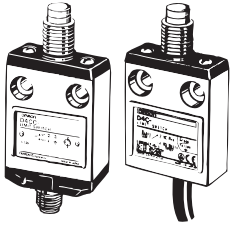

VCTF cable, 0.75 mm<sup>2</sup>, 4 conductor  
Finishing O.D.: 7.6

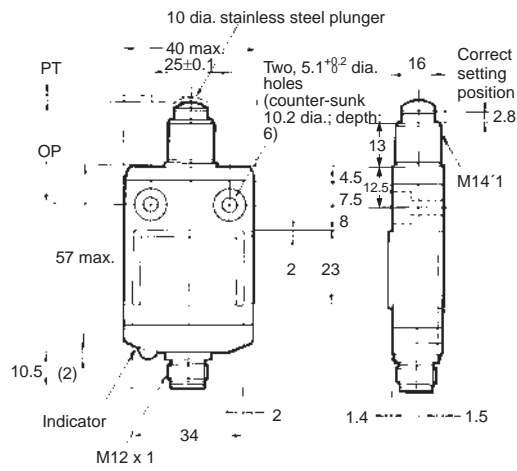
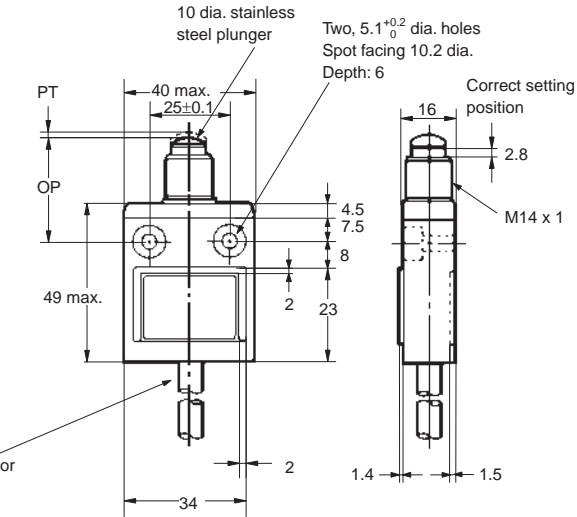

Roller plunger with M14 mounting

D4C-□□42  
D4CC-□□42

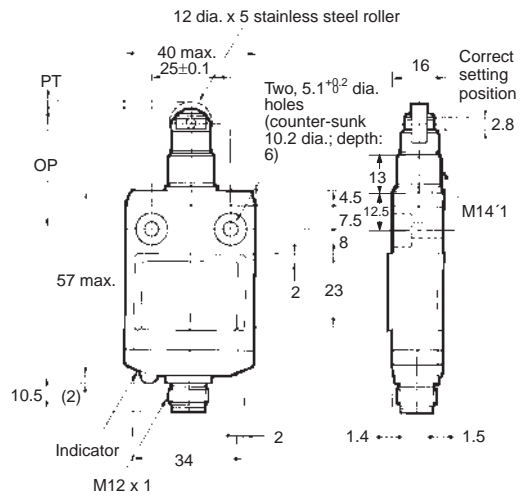
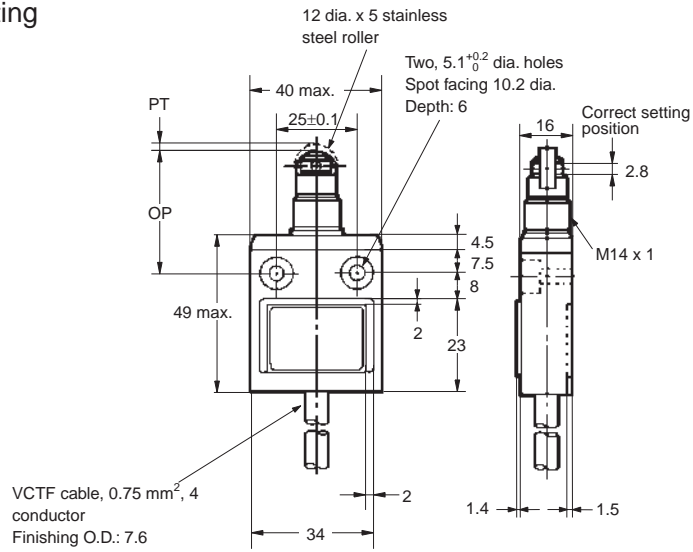
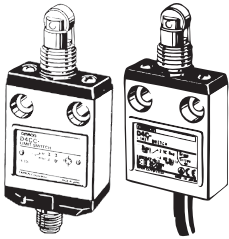

Crossroller plunger with M14 mounting

D4C-□□43  
D4CC-□□43

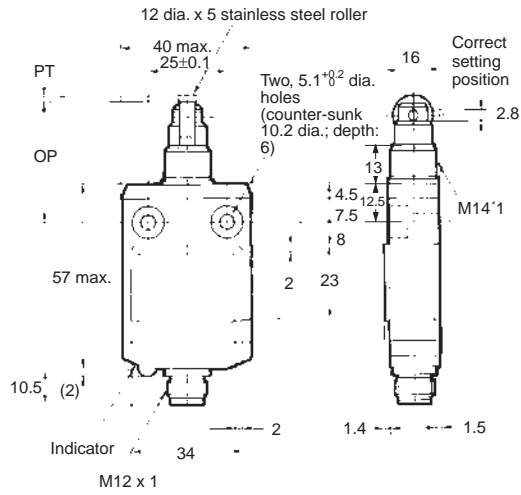
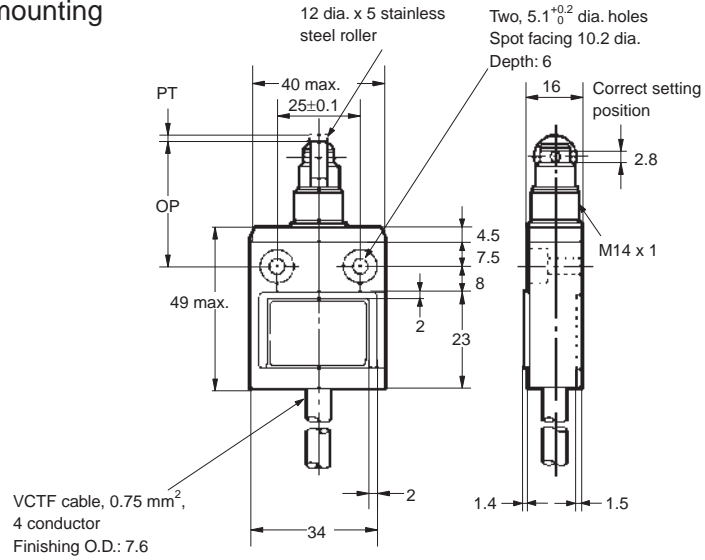
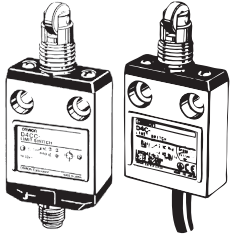

Coil spring

D4C-□□50  
D4CC-□□50

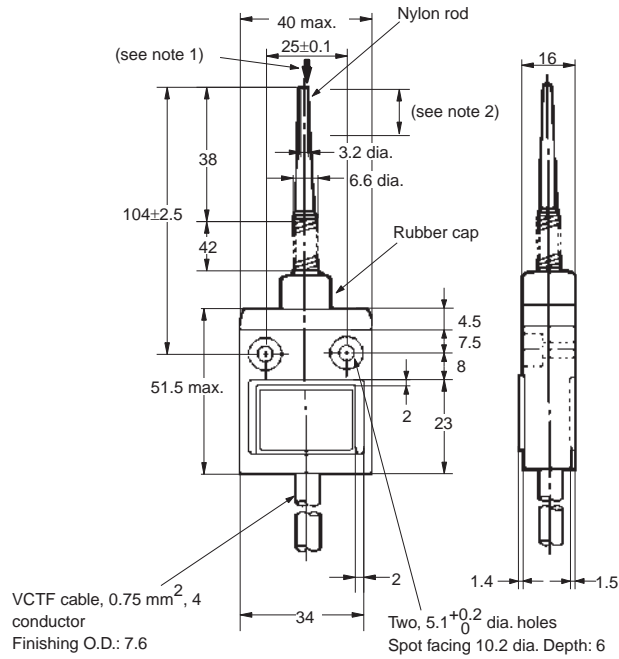
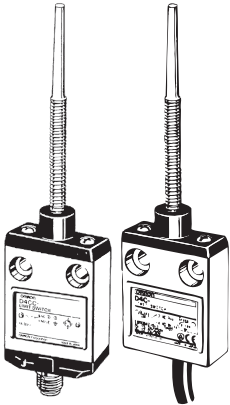

- Note:** 1. Operation is possible in any direction except in parallel to the axis.
2. The ideal range for operation is between the tip of the rod and 1/3 of the length of the actuator.

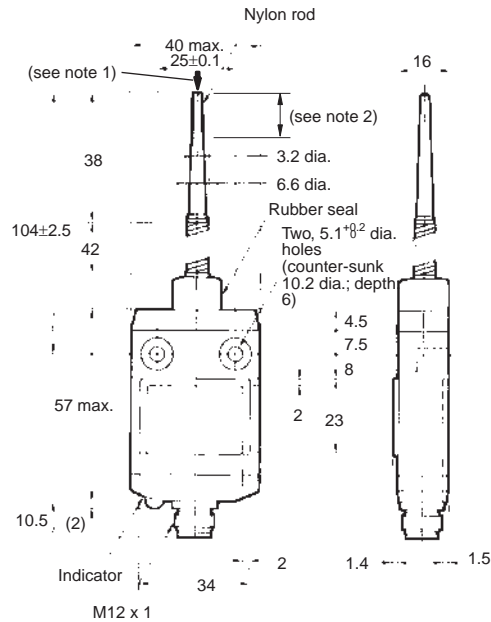

Models with LED indicator

The dimensions of the LED indicator for models equipped with one are shown below.

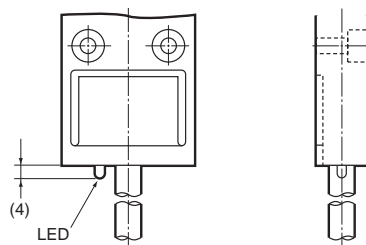

## Precautions

### Correct Use

#### Handling

The bottom of the Switch at the cable outlet is resin-molded. Secure the cable at a point 5 cm from the Switch bottom to prevent exertion of excess force on the cable.

When bending the cable, provide a bending radius of 45 mm min. so as not to damage the cable insulation or sheath. Excessive bending may cause fire or leakage current.

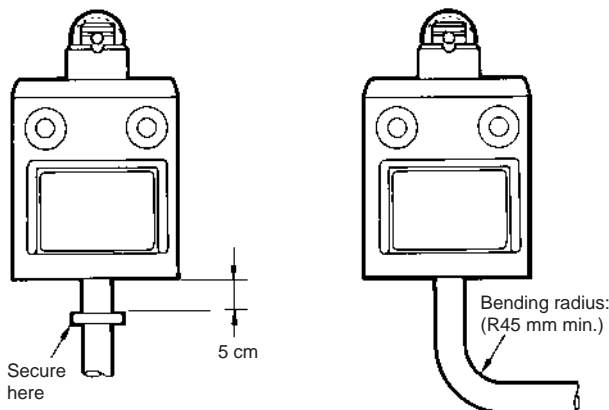

#### Connections

Be sure to connect a fuse with a breaking current 1.5 to 2 times larger than the rated current to the Limit Switch in series in order to protect the Limit Switch from damage due to short-circuiting. When using the Limit Switch for the EN ratings, use the gI or gG 10-A fuse.

#### Operation

Operation method, shapes of cam and dog, operating frequency, and overtravel have a significant effect on the service life and precision of a Limit Switch. For this reason, the dog angle must be 30° max., the surface roughness of the dog must be 6.3S min. and hardness must be Hv400 to 500.

To allow the plunger-type actuator to travel properly, adjust the dog and cam so that the plunger groove fits the bushing top.

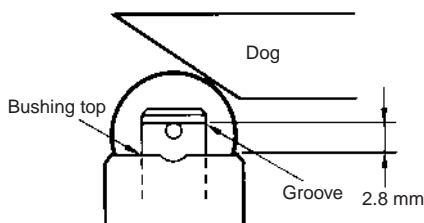

To allow the roller lever-type actuator to travel properly, adjust the dog and cam so that the arrow head is positioned between the two convex markers as shown below.

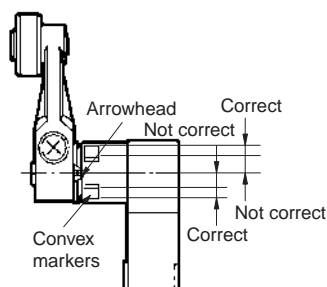

### Plug tightening

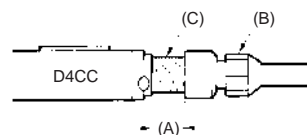

Connect the plug connector (B) to the connector threads of the D4CC. Then firmly turn the plug connector by hand so that the connector threaded portion (C) will be completely covered by the plug connector (B) so that space (A) will be almost 0. Do not use any tools, such as pliers, to tighten the plug connector, otherwise the plug connector may become damaged. Make sure, however, that the plug connector is tightened securely, otherwise the rated degree of protection of the D4CC may not be maintained. Furthermore, the plug connector may be loosened by vibration.

#### Properly tightened connector

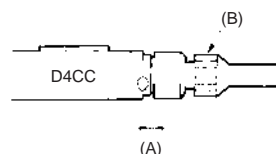

### Mounting

A maximum of 6 Switches may be group-mounted. In this case, pay attention to the mounting direction so that the convex part of the group-mounting guide on one Switch fits into the concave part of the guide on the other Switch as shown in the figure below. For group mounting, the mounting panel must have a thickness (t) of 6 mm min.

#### Group mounting

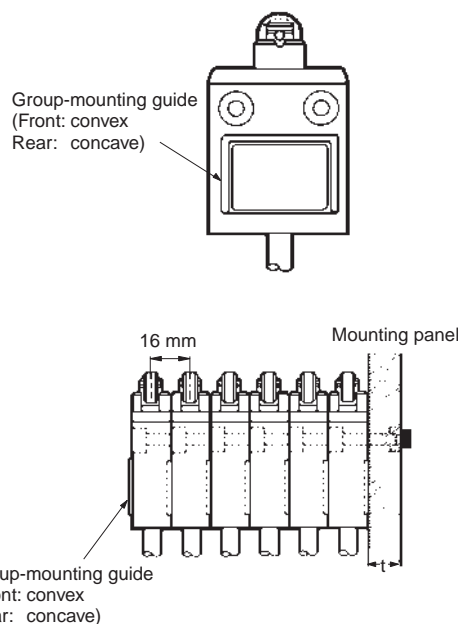

If the mounting panel is warped or has protruding parts, a malfunction may result. Make sure that the mounting panel is not warped and has even surfaces.

#### Mounting Holes

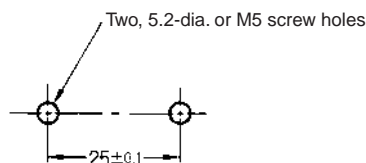

Use a Switch with a rubber cap when using the plunger type in an environment where malfunction is possible due to environmental conditions such as dust or cutting chips which may not allow resetting.



Do not expose the Switch to water exceeding 70°C or use it in steam. When the D4C is used in a circuit of a device to be exported to Europe, classified as Overvoltage Class III as specified in IEC664, provide a contact protection circuit. Tighten each screw to a torque according to the following table.

No.	Type	Torque
1	M5 Allen-head bolt	4.90 to 5.88 N·m
2	M3.5 head mounting screw	0.78 to 0.88 N·m
3	M5 Allen-head bolt	4.90 to 5.88 N·m

By removing the two screws from the head, the head direction can be rotated 180°. After changing the head direction, re-tighten to the torque specified above. Be careful not to allow any foreign substance to enter the Switch.

**Micro-load Models (D4C-6)**

**Switching Range**

Micro-load models can be used for switching in the range shown below.

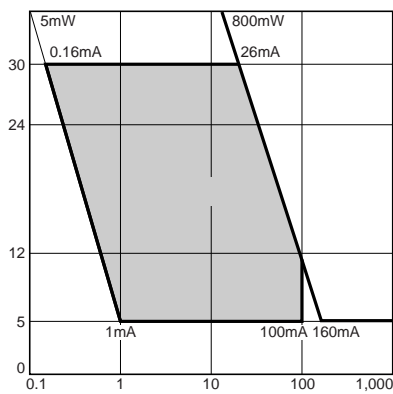

---

**WARRANTY**

OMRON's exclusive warranty is that the products are free from defects in materials and workmanship for a period of one year (or other period if specified) from date of sale by OMRON.

OMRON MAKES NO WARRANTY OR REPRESENTATION, EXPRESS OR IMPLIED, REGARDING NON-INFRINGEMENT, MERCHANTABILITY, OR FITNESS FOR PARTICULAR PURPOSE OF THE PRODUCTS. ANY BUYER OR USER ACKNOWLEDGES THAT THE BUYER OR USER ALONE HAS DETERMINED THAT THE PRODUCTS WILL SUITABLY MEET THE REQUIREMENTS OF THEIR INTENDED USE. OMRON DISCLAIMS ALL OTHER WARRANTIES, EXPRESS OR IMPLIED.

**LIMITATIONS OF LIABILITY**

OMRON SHALL NOT BE RESPONSIBLE FOR SPECIAL, INDIRECT, OR CONSEQUENTIAL DAMAGES, LOSS OF PROFITS OR COMMERCIAL LOSS IN ANY WAY CONNECTED WITH THE PRODUCTS, WHETHER SUCH CLAIM IS BASED ON CONTRACT, WARRANTY, NEGLIGENCE, OR STRICT LIABILITY.

In no event shall responsibility of OMRON for any act exceed the individual price of the product on which liability is asserted.

IN NO EVENT SHALL OMRON BE RESPONSIBLE FOR WARRANTY, REPAIR, OR OTHER CLAIMS REGARDING THE PRODUCTS UNLESS OMRON'S ANALYSIS CONFIRMS THAT THE PRODUCTS WERE PROPERLY HANDLED, STORED, INSTALLED, AND MAINTAINED AND NOT SUBJECT TO CONTAMINATION, ABUSE, MISUSE, OR INAPPROPRIATE MODIFICATION OR REPAIR.

**SUITABILITY FOR USE**

THE PRODUCTS CONTAINED IN THIS DOCUMENT ARE NOT SAFETY RATED. THEY ARE NOT DESIGNED OR RATED FOR ENSURING SAFETY OF PERSONS, AND SHOULD NOT BE RELIED UPON AS A SAFETY COMPONENT OR PROTECTIVE DEVICE FOR SUCH PURPOSES. Please refer to separate catalogs for OMRON's safety rated products.

OMRON shall not be responsible for conformity with any standards, codes, or regulations that apply to the combination of products in the customer's application or use of the product.

At the customer's request, OMRON will provide applicable third party certification documents identifying ratings and limitations of use that apply to the products. This information by itself is not sufficient for a complete determination of the suitability of the products in combination with the end product, machine, system, or other application or use.

The following are some examples of applications for which particular attention must be given. This is not intended to be an exhaustive list of all possible uses of the products, nor is it intended to imply that the uses listed may be suitable for the products:

- Outdoor use, uses involving potential chemical contamination or electrical interference, or conditions or uses not described in this document.
- Nuclear energy control systems, combustion systems, railroad systems, aviation systems, medical equipment, amusement machines, vehicles, safety equipment, and installations subject to separate industry or government regulations.
- Systems, machines, and equipment that could present a risk to life or property.

Please know and observe all prohibitions of use applicable to the products.

NEVER USE THE PRODUCTS FOR AN APPLICATION INVOLVING SERIOUS RISK TO LIFE OR PROPERTY WITHOUT ENSURING THAT THE SYSTEM AS A WHOLE HAS BEEN DESIGNED TO ADDRESS THE RISKS, AND THAT THE OMRON PRODUCT IS PROPERLY RATED AND INSTALLED FOR THE INTENDED USE WITHIN THE OVERALL EQUIPMENT OR SYSTEM.

**PERFORMANCE DATA**

Performance data given in this document is provided as a guide for the user in determining suitability and does not constitute a warranty. It may represent the result of OMRON's test conditions, and the users must correlate it to actual application requirements. Actual performance is subject to the OMRON Warranty and Limitations of Liability.

**CHANGE IN SPECIFICATIONS**

Product specifications and accessories may be changed at any time based on improvements and other reasons.

It is our practice to change model numbers when published ratings or features are changed, or when significant construction changes are made. However, some specifications of the product may be changed without any notice. When in doubt, special model numbers may be assigned to fix or establish key specifications for your application on your request. Please consult with your OMRON representative at any time to confirm actual specifications of purchased products.

**DIMENSIONS AND WEIGHTS**

Dimensions and weights are nominal and are not to be used for manufacturing purposes, even when tolerances are shown.

**ERRORS AND OMISSIONS**

The information in this document has been carefully checked and is believed to be accurate; however, no responsibility is assumed for clerical, typographical, or proofreading errors, or omissions.

**PROGRAMMABLE PRODUCTS**

OMRON shall not be responsible for the user's programming of a programmable product, or any consequence thereof.

---

**OMRON EUROPE B.V.**

Wegalaan 67-69,  
 NL-2132 JD, Hoofddorp,  
 The Netherlands  
 Phone: +31 23 568 13 00  
 Fax: +31 23 568 13 88  
 www.industrial.omron.eu