

MAC CENTRE

T. 34 93 214 06 00 F. 34 93 214 06 31
Olesa 14-16 6ª floor 08027 BARCELONA

OMRON

SERIAL COMMUNICATIONS WITH SMART STEP SERVODRIVER



INDEX

0. - INTRODUCTION	2
1. - HARDWARE CONNECTION	2
1.1. - COMMUNICATIONS CONNECTOR SPECIFICATIONS	4
2. - COMMUNICATION PROTOCOL	5
2.1. - BASIC SPECIFICATIONS	5
2.2. - COMMUNICATION MODE	5
3. - USER PARAMETERS AND STATUS DISPLAY ADDRESSES	7
4. - DATA TRACE FUNCTION	10
5. - COMMAND PULSE COUNTER CLEAR FUNCTION	17
6. - FEEDBACK PULSE COUNTER CLEAR FUNCTION	17

0. - INTRODUCTION

The present document intends to guide you about how to use the serial communications in the Smart Step servodriver. Most of the concepts and explanation are also valid for the W series servodriver.

1. - HARDWARE CONNECTION

(1) Transmission distance:

CN1: 30 m max. (Total length of communications lines for RS-422A/485.)
2 m max. (for RS-232C)

CN3: 2 m max.

(2) Transmission type:

CN1: RS-422A/485 (non-isolated type)

CN3: Operation at RS-232C level (non-isolated type)

(3) Reception circuit on the SmartStep driver (CN-1)

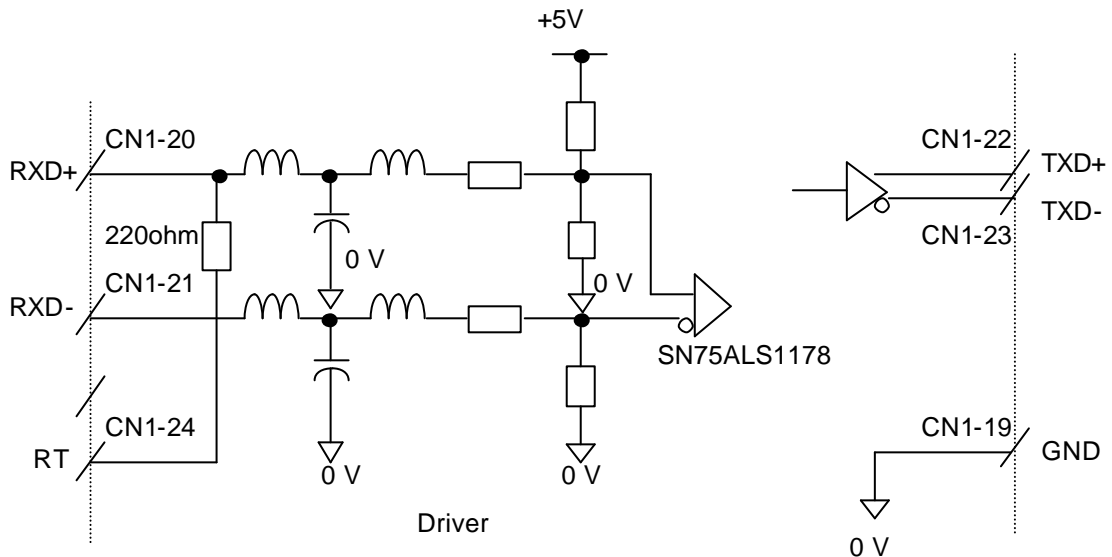

(4) Single-axis Communications Mode

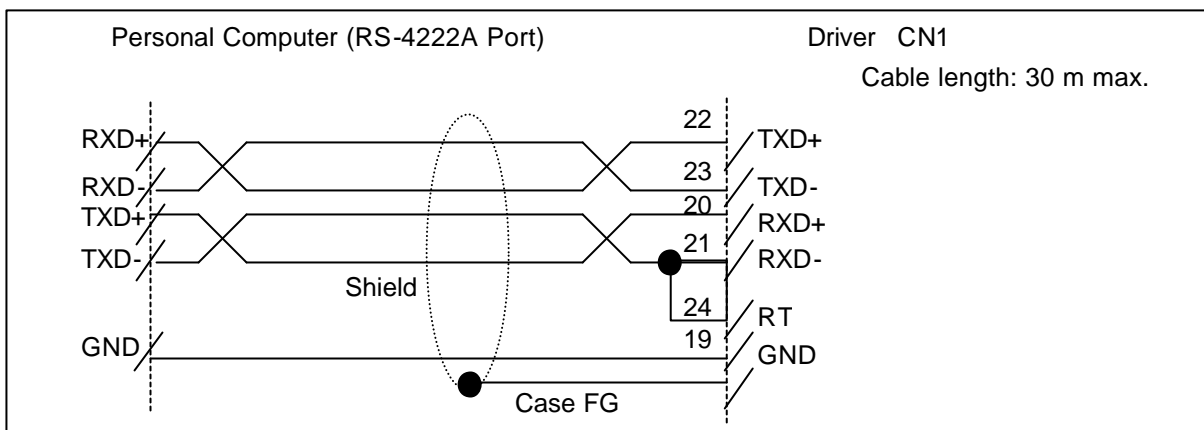

- SMART STEP serial communications -

If the cable length for one axis is no more than two meters, it is also possible to connect directly to the RS-232C port as shown below.

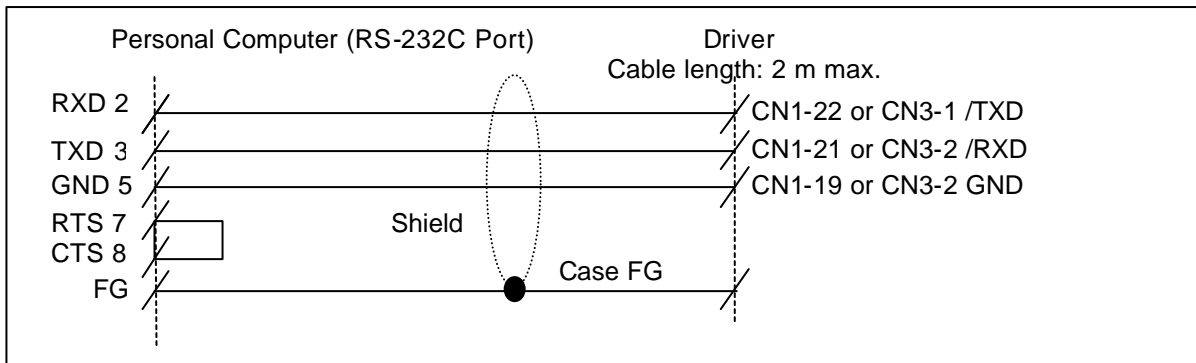

Depending on the personal computer, some communications may not function properly when connected directly to CN1. In that case, use an RS-232C/RS-422A converter.

(5) Multi-axis Communications Mode

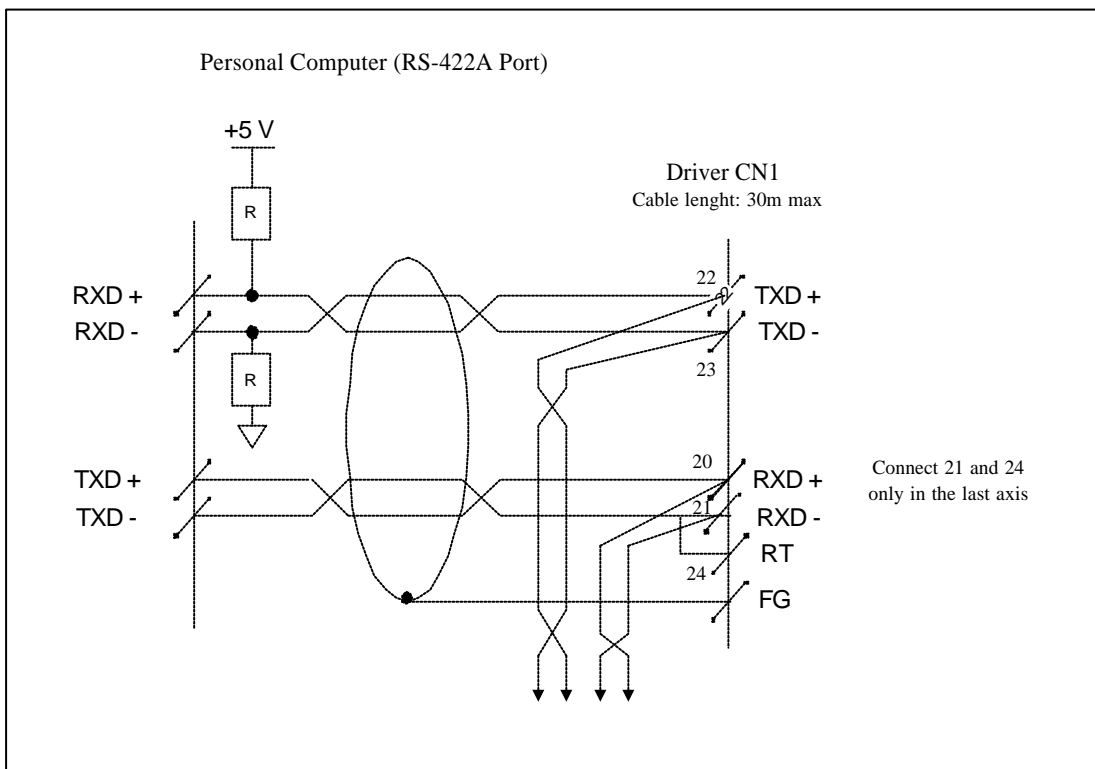

Connect the shield to the frame ground inside the Servodriver through the connector case. When executing communications for multiple axes, the Driver frame grounds must be connected to the same point.

Note) Resistance: 1 Kohm to 10 Kohm

1.1. – COMMUNICATIONS CONNECTOR SPECIFICATIONS

(1) Driver: CN1 Pin Functions

Pin No.	Signal name	Signal circuit name	Signal direction
19	GND	Ground	
20	RXD+	Receive Data (+)	P -> D
21	RXD-	Receive Data (-)	P -> D
22	TXD+	Send Data (+)	P <- D
23	TXD-	Send Data (-)	P <- D
24	RT	If pins 21 and 24 are short-circuited, a terminating resistance of 220OHM is required between RXD+ and RXD-.	
Shell	FG	Shield (frame ground)	

P: Personal computer; D: Servodriver

Do not wire to pins indicated by #.

Inside Servodriver:

10236-52AJL (Sumitomo 3M)

Applicable connector, plug (soldered):

10136-3000VE (Sumitomo 3M)

Case:

10336-50A0-008 (Sumitomo 3M)

(2) Driver: CN3 Pin Functions

Pin No.	Signal name	Signal circuit name	Signal direction
1	/ TXD	Send Data	P <- D
2	/ RXD	Receive Data	P -> D
3	PRMU	Unit Switching	#
7	+5V	+5-V output	#
8	GND	Ground	
Shell	FG	Shield (frame ground)	

P: Personal computer; D: Servodriver

Do not wire to pins indicated by #.

Inside Servodriver: HR12-10R-8SDL (Hirose Electric)

Applicable connector: HR212-10P-8P (Hirose Electric)

Here there is a picture of these connectors



2. – COMMUNICATION PROTOCOL

2.1. – BASIC SPECIFICATIONS

The SmartStep is prepared to work with these settings so make the proper changes to meet this configuration.

(1) Baud rate: 9,600 bps

(2) Number of bits: Start: 1 bit
 Data: 7 bits (ASCII)
 Stop: 1 bit
 Even parity: 1 bit

(3) Synchronization method: Start-stop synchronization

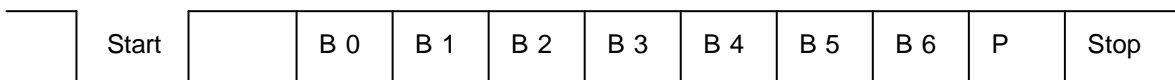

(4) XON/XOFF: None

(5) Shift control: None

(6) Communications mode: Half-duplex communications

The Servodriver returns a response within 0.2 s but it doesn't return a response in the following cases:

1. When a parity error or framing error occurs.
2. When the number of characters for the command is not 14.
3. When the command doesn't begin with one valid communication mode W00, W01 or W02 (see point 2.1 for more information)
4. When the command does not end with a CR code.
5. When hexadecimal is not used where it should be.
6. When a checksum error occurs.

Set up communications so that the personal computer sends a command and waits for the response, and then sends the next command after the response has been completely received. Set it up so that a command will be resent if no response has been received within 0.2 s.

2.2. – COMMUNICATION MODE

Communications are executed using send commands from the personal computer and the response to these commands from the Servodriver.

For commands and responses the character string "Wncaaaaddss [CR]" (14 characters) is sent and received in JIS code (same than the ASCII code for 7-bit code).

Command (personal computer -> Servodriver)

Data reference command	Wn0aaaa0000ss [CR]
Data setting command	Wn1aaaaddss [CR]
Data string reference command	Wn2aaaabbbss [CR]

Response (Servodriver -> personal computer)

Wneaaaaddss [CR]
Wn2aaaabbbssddd •••• dddd [CR]

- SMART STEP serial communications -

(1) Address

The address is given in aaaa.

Refer to the Correspondence of Addresses and User Parameters for Drivers table on the following pages.

(2) Data

The data is given in dddd.

User parameter data and status display data are expressed in hexadecimal.

(3) Number of Bytes

The number of bytes is given in bbbb.

The number of bytes in the referenced data string is expressed in hexadecimal.

(4) Checksum

The checksum is given in ss.

If the command or response is $Wn_1c_1a_1a_2a_3a_4d_1d_2d_3d_4s_1s_2$ [CR], set so that the rightmost byte of $n_1c_1+a_1a_2+a_3a_4+d_1d_2+d_3d_4+s_1s_2$ becomes 00H for hexadecimal addition (two's complement).

Example: When command $W0000010000s_1s_2$ [CR] is issued:

$00H+00H+01H+00H+00H+ s_1s_2=X_100H$ (X: Any n)

$s_1s_2=X_100H-01H=FFH$

(5) Status

"e" is the response status.

Response to data reference command:	Normal: 0 Address error: 8 Data error: 4
Response to data setting command:	Normal: 1 Address error: 9 Data error: 5
Response to data string reference command:	Normal: 2 Address error: A Error in number of bytes: 6

(6) Unit No. The unit number is indicated by n.

-When Pn000.2 (Unit No.) = 0, the communications mode is single-axle mode and transmission is always enabled. Commands are sent when n = 0.

-When Pn000.2 (Unit No.) ≠ 0, the communications mode is multi-axle mode and transmission is enabled only when responses are received. Communications are open for TXD+ and TXD-. Commands are executed and responses returned only when the Pn000.2 setting matches the communications command unit number,

(7) [CR]

[CR] is the ODH carriage return code in JIS code.

Example: Executing communications for Unit #0.

1. Reference Pn100 (EEPROM Area). (When Pn100 = 40 [0028H])

Command: W0001000000FF [CR]

Response: W0001000028D7 [CR]

2. Set Pn304 (EEPROM Area) to 1000 (03E8H).

Command: W01030403E80D [CR]

Response: W01030403E80D [CR]

3. If address C000H is referenced by mistake:

Command: W00C000000040 [CR]
Response: W08C000000038 [CR]

4. If 1000 is set to address C000H by mistake:

Command: W00C00003E855 [CR]
Response: W09C00003E84C [CR]

5. If data 40 (0028H) is set by mistake to Pn100 (EEPROM Area) at the time of the reference command:

Command: W0001000028D7 [CR]
Response: W0401000028D3 [CR]

6. If 3000 (0BB8H) is set by mistake to Pn100 (EEPROM Area) at the time of the setting command (over the upper limit of 2000):

Command: W0101000BB83B [CR]
Response: W0501000BB837 [CR]

Note:

Writing to the Parameter Area is executed using either EEPROM or RAM. The EEPROM provided in the Servodriver can be overwritten up to 10,000 times. Once this service life is exceeded, writing is no longer possible. If frequent writing is required, write to RAM instead of EEPROM. The RAM, however, is cleared when the power is turned OFF.

3. – USER PARAMETERS AND STATUS DISPLAY ADDRESSES

Correspondence of Addresses and User Parameters for Drivers (Read/Write Area)

EEPROM address	RAM address	PRM No.	Parameter name
0000H	1000H	Pn000	Basic switch 1
0001H	1001H	Pn001	Basic switch 2
0100H	1100H	Pn100	Speed loop gain
0101H	1101H	Pn101	Speed loop integral time constant
0102H	1102H	Pn102	Position loop gain
0103H	1103H	Pn103	Inertia rate
0109H	1109H	Pn109	Feed forward amount
010AH	110AH	Pn10A	Feed forward reference filter
0110H	1110H	Pn110	Online auto-tuning setting
0200H	1200H	Pn200	Position control setting 1
0202H	1202H	Pn202	Electronic gear ratio G1 (numerator)
0203H	1203H	Pn203	Electronic gear ratio G2 (denominator)
0204H	1204H	Pn204	Position reference filter time constant 1 (primary filter)
0207H	1207H	Pn207	Position control setting 2
0208H	1208H	Pn208	Position reference filter time constant 2 (linear acceleration/deceleration)
0304H	1304H	Pn304	JOG speed
0401H	1401H	Pn401	Torque reference filter time constant
0402H	1402H	Pn402	Forward torque limit
0403H	1403H	Pn403	Reverse torque limit
0500H	1500H	Pn500	Position complete width
0505H	1505H	Pn505	Deviation counter over level
0600H	1600H	Pn600	Regeneration resistance capacity

Correspondence of Addresses and Driver Status Displays

Address	Monitor No.	Monitoring contents	Unit	Sign
8000H	Un000	Speed feedback	r/min	S
8001H	Un001	Speed reference	r/min	S
8002H	Un002	Torque reference	%	S
8003H	Un003	Number of pulses from phase Z	Pulses	U
8004H	Un004	Electrical angle	Degrees	U
8005H	Un005	Input signal monitoring	-	-
8006H	Un006	Output signal monitoring	-	-
8007H	Un007	Reference pulse speed display	r/min	S
8008H	Un008	Position deviation (deviation counter)	Command units	S
8009H	Un009	Cumulative load ratio	%	U
800AH	Un00A	Regenerative load ratio	%	U
800BH	Un00B	Dynamic brake resistance load ratio	%	U
800CH	Un00C	Input pulse counter (rightmost 16 bits)	Command units	U
800DH	Un00C	Input pulse counter (leftmost 16 bits)	Command units	U
800EH	Un00D	Feedback pulse counter (rightmost 16 bits)	Pulse	U
800FH	Un00D	Feedback pulse counter (leftmost 16 bits)	Pulse	U
8105H		Gain rotary switch setting status		-
8106H		Function selection switch setting status		-
8500H	Fn000-0	Alarm history Error #0	Alarm code	-
8501H	Fn000-1	Error #1	Alarm code	-
8502H	Fn000-2	Error #2	Alarm code	-
8503H	Fn000-3	Error #3	Alarm code	-
8504H	Fn000-4	Error #4	Alarm code	-
8505H	Fn000-5	Error #5	Alarm code	-
8506H	Fn000-6	Error #6	Alarm code	-
8507H	Fn000-7	Error #7	Alarm code	-
8508H	Fn000-8	Error #8	Alarm code	-
8509H	Fn000-9	Error #9	Alarm code	-
850AH		Present alarm status	Alarm code	-
850BH	Fn007	Auto-tuning result	%	U
8518H	Fn012-R	Servodriver software version	-	U
8800H		Servodriver type	-	-

Note: Sign

S: Data with sign; U: Data without sign; -: Code

Digital Input status

In address 8005H is possible to monitor the status of the input signals. This table shows in which bit represent each input. The logic is expressed by the signals just as they are. (High: 1; low: 0)

Bits	Pin No.	Default allocation
0	CN1-14	RUN
1 to 3	Not used.	Not used.
4	CN1-18	RESET
5 to 15	Not used.	Not used.

Digital output status

Also is possible to monitor the Output Signals status in the address 8006H. Like in the input status this table shows the bit assignation for the digital outputs. Logic is expressed by the signals just as they are. (High: 1; low: 0)

Bits	Pin No.	Default allocation
0	CN1-34	/ALM
1	CN1-8	INP
2 to 5	Not used.	Not used.
6	CN1-7	BKIR
7 to 15	Not used.	Not used.

Alarm Table

Data is returned for present alarms and alarm logs according to the alarm contents as shown in the following table.

Reference data	Alarm contents
0004H	Parameter setting error
0010H	Overcurrent
0030H	Regeneration error
0032H	Regeneration overload
0040H	Overvoltage/undervoltage
0051H	Overspeed
0070H	Overload
0073H	Dynamic brake overload
0074H	Inrush resistance overload
007AH	Radiator overheating
00BFH	System error
00C1H	Runaway detected
00C2H	Phase error detected
00C3H	Encoder disconnection detected
00D0H	Deviation counter over
0091H	Overload alarm
0092H	Regeneration overload alarm
0099H	Normal (No alarm, See note.)

Note: The "0099" that indicates normal status is not an alarm code, but is an identifier that indicates that there is no alarm. Set up so that "A.99" is not displayed.

Driver Type (8800H)

Enables the Driver type to be read.

Reference data	Driver model number
0CH	R7D-APL
0CH	R7D-APH

Gain Rotary Switch Setting Status (8105H)

Enables monitoring of the overall gain rotary switch setting status for the Driver.

Reference data	Switch setting
0000H	0
---	---
000FH	F

Function Selection Switch Setting Status (8106H)

Enables monitoring of the overall function selection switch setting status for the Driver. (ON: 1; OFF: 0) Reflects the switch selection status.

Bits	Switch setting allocations
0	No. 1 (Online auto-tuning setting)
1	No. 2 (Dynamic brake setting)
2	No. 3 (Command pulse input setting)
3	No. 4 (Resolution setting)
4	No. 5 (Resolution setting)
5	No. 6 (Switch/Parameter setting enable switch)
6 to 15	Not used.

4. – DATA TRACE FUNCTION

When Data Trace Mode is set as the operating mode, 500 points of the specified operation data for each sampling period can be saved in the SERVOPACK memory, and this data can be referenced.

Related Addresses

Address	Contents	Abbreviation
2000H	Operating mode setting/reference	
2001H	Operation setting (setting only)	
3000H to 33E7H	Trace 1	
3800H to 3BE7H	Trace 2	
5000H	Trace 1 object selection	
5001H	Trace 2 object selection	
5002H	Sampling interval	SMPTMS
5003H	Number of pre-trigger data items	PTRGNO
5004H	Trigger condition	TRGC1
5005H	Trigger level	TRGC2
5006H	Trigger address	TRGADR
5100H	Trace 1 object address	
5101H	Trace 2 object address	
8700H	Sampling time unit	CYCLEC
8701H	Maximum monitoring torque (%)	MAXTRQC
8702H	Maximum monitoring speed (r/min)	OSVELCC

Maximum torque and speed that are setting in these parameters will be take as reference so this values would correspond with a 15.000.

This one is useful to increase the resolution of the trace if the torque or speed that we will use is lower than the servo rated one.

Note: Data Setting Limit

While in Data Trace Mode, setting addresses other than “operating mode setting/reference (2000H)” and “operation setting (2001H)” is prohibited. (If another address is set, “address error” will be returned as a response.)

Settings

1. Operating Mode Setting (2000H)

Setting	Contents
2000H	Data Trace Mode
0000H	Normal Mode

After entering Data Trace Mode, the mode is returned to Normal Mode when trace processing has been completed. To end trace processing or trigger waiting while still in

Data Trace Mode after execution has been started, set the operating mode to Normal Mode.

2. Operation Setting (2001H)

Setting	Contents
0001H	Execution

Setting “1” starts the data trace. If a trigger condition is set, operation enters in trigger waiting status and waits for the trigger condition to be satisfied.

With the data trace processing 500 points for each selected trace (1,2 or both) are stored into memory at the specified cycle.

Upon completion of the trace, the operating mode is referenced (read) to determine when it is in Normal Mode.

After the trace has been completed read the trace data using the data string reference command.

3. Trace 1, Trace 2 signal selection (5000H, 5001H)

Selects the objects to be stored in Trace 1 and Trace 2 in the Trace Area.

For the normal setting, one data object and one I/O data item can be selected for each Trace Area aspect.

The setting format consists of two bytes, one leftmost and one rightmost, as shown below.

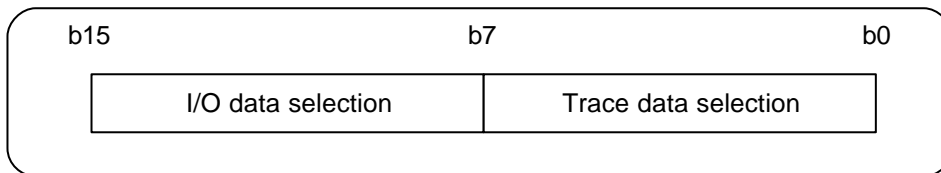

The data format for each point in the Trace Memory Area is as shown below.

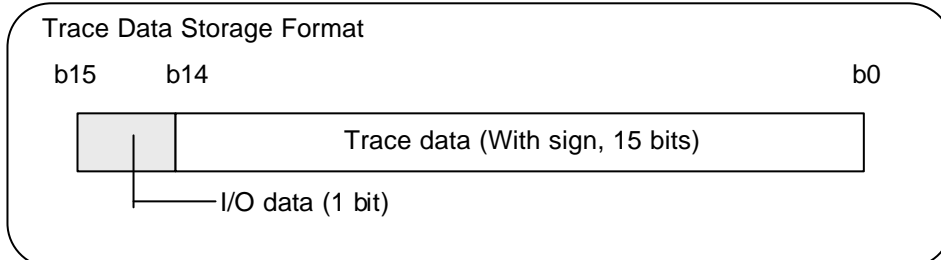

* Trace Data Selection

Any of the objects shown in the following table can be selected for the trace data selection in the rightmost byte.

Trace Data Selection

Setting	Object	Unit	Remarks Limitations
00H	Torque reference	x MAXTRQC / 15,000 %	None
01H	Speed feedback	x OSVELCC / 15,000 r / min	None
03H	Command pulse speed	/ (2 x CYCLEC) pulse	For position control
04H	Position deviation	Command unit	For position control

Note: Unit Conversion

Read trace data other than “position deviation” is used by the reference data shown in the following table for unit conversion.

Abbreviation	Reference address	Contents
CYCLEC	8700H	Sampling time unit
MAXTRQC	8701H	Torque reference when data is 15,000 (%)
OSVELCC	8702H	Speed when data is 15,000 (r/min)
RATB	0202H	Electronic gear ratio (numerator)
RATA	0203H	Electronic gear ratio (denominator)

- SMART STEP serial communications -

1) Torque Reference

$$\text{Torque reference (\%)} = \text{Data} \times \text{MAXTRQC} / 15,000$$

2) Speed Feedback / Command Speed

$$\text{Speed (r/min)} = \text{Data} \times \text{OSVELCC} / 15,000$$

3) Command Pulse Speed

$$\text{Command pulse speed (r/min)} =$$

$$\text{Data} \cdot \frac{\text{RATA}}{\text{RATB}} \cdot \frac{60 \cdot 1000 \cdot 1000}{\text{CYCLEC} \cdot 2} \cdot \frac{1}{8000}$$

4) I/O data selection

Any of the objects shown in the following table can be selected for the I/O data selection in the leftmost byte. Logic is expressed by the signals just as they are. (High: 1; low: 0)

Setting	Object
00H	RUN
06H	RESET
80H	/ALM
81H	INP
87H	BKIR

5) Sampling Interval (5002H)

To set the sampling time for data trace or table operation to ST (?s), set SMPTMS=ST/CYCLEC. The data will be saved to trace memory with each time ST.

Abbreviation	Reference address	Contents
CYCLEC	8700H	Sampling time unit

The sampling interval can be set from 2 to FFFF.

Caution: Even if 0 or 1 is set a data error will not be generated.

6) Number of Pre-trigger Data Items (5003H)

Trace 1 and Trace 2 store 500 points each one into the Trace Area. Set in this address how many of these points are to be for data items prior to trigger detection. If there is no trigger, this setting is invalid.

7) Trigger Condition (5004H)

Set the trigger object and condition for data trace. The setting is as shown in the following diagram.

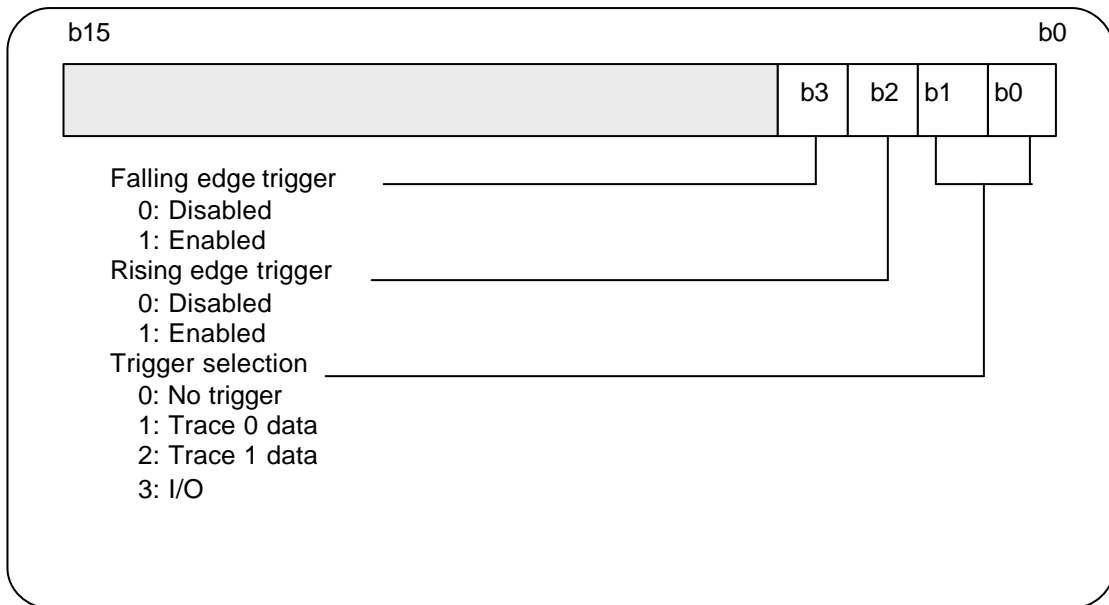

If falling and rising edges are both enabled, the trigger is detected when the data is changed from its previous value. If they are both disabled, it is regarded as “no trigger.”

8) Trigger Level (5005H)

The meaning of the trigger level varies as shown below, depending on whether the trigger selected for the trigger condition is trace data or I/O data. If there is no trigger, this setting is invalid.

* When Trigger is Trace Data

The trigger level is set by data with sign.

The values that are set for other than “position deviation” are the values following conversion by the reference data shown below.

Abbreviation	Reference address	Contents
CYCLEC	8700H	Sampling time unit
MAXTRQC	8701H	Torque reference when data is 15,000 (%)
OSVELCC	8702H	Speed when data is 15,000 (r/min)
RATB	0202H	Electronic gear ratio (numerator)
RATA	0203H	Electronic gear ratio (denominator)

Unit Conversion

1. Torque reference

$$\text{Data} = \text{Torque reference (\%)} \cdot 15,000 / \text{MAXTRQC}$$

2. Speed Feedback/Command Speed

$$\text{Data} = \text{Speed (r/min)} \cdot 15,000 / \text{OSVELCC}$$

3. Command Pulse Speed

Data =

$$\text{Command pulse speed (r/min)} \cdot \frac{\text{RATB}}{\text{RATB}} \cdot \frac{\text{CYCLEC} \cdot 2}{60 \cdot 1000 \cdot 1000} \cdot 8000$$

When Trigger is I/O Data

The only I/O data that can serve as the trigger condition is the I/O data selected by the Trace 1 or Trace 2 object selection. This setting specifies which I/O data is to serve as the trigger.

Setting	Object
0000H	I/O data specified by Trace 1 object selection.
0001H	I/O data specified by Trace 2 object selection.

9) Trigger Address (5006H)

After the trace is completed, the address where the trigger was detected can be found by referencing this address. Data is detected from this trigger address (TRGADR), the number of pre-trigger data items (PRTGNO) that is set, and the total number of points (500) for each Trace Area aspect

Trigger data (Data prior to occurrence of trigger)
 (TRGADR - PRTGNO) to (TRGADR - 1)

Post-trigger data (Data after detection of trigger)
 TRGADR to (TRGADR + PRTGNO - 1)

However, if $(TRGADR - PRTGNO) < 0$, reference $500 + (TRGADR - PRTGNO)$.
 If $(TRGADR + PRTGNO - 1) > 499$, reference 499.

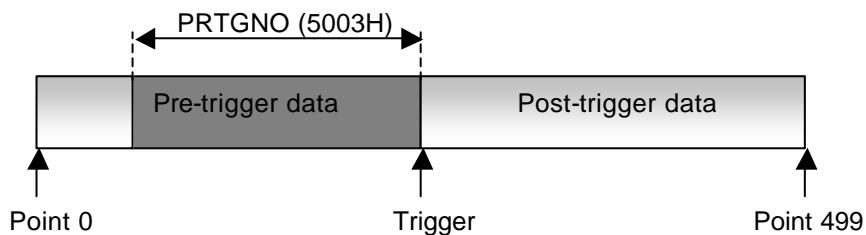

This trigger address expresses a position within the 500 points, so the actual addresses become:

- Trace 1: +3000H
- Trace 2: +3800H

Note

- 1) In relation to the trigger detection cycle, there may be a maximum delay of 2 ms from the time that the trigger condition is satisfied until the trigger is detected.
- 2) The trigger may be missed for a short time (2 ms max.).

(3) Processing Procedure

The data trace processing procedure is as follows:

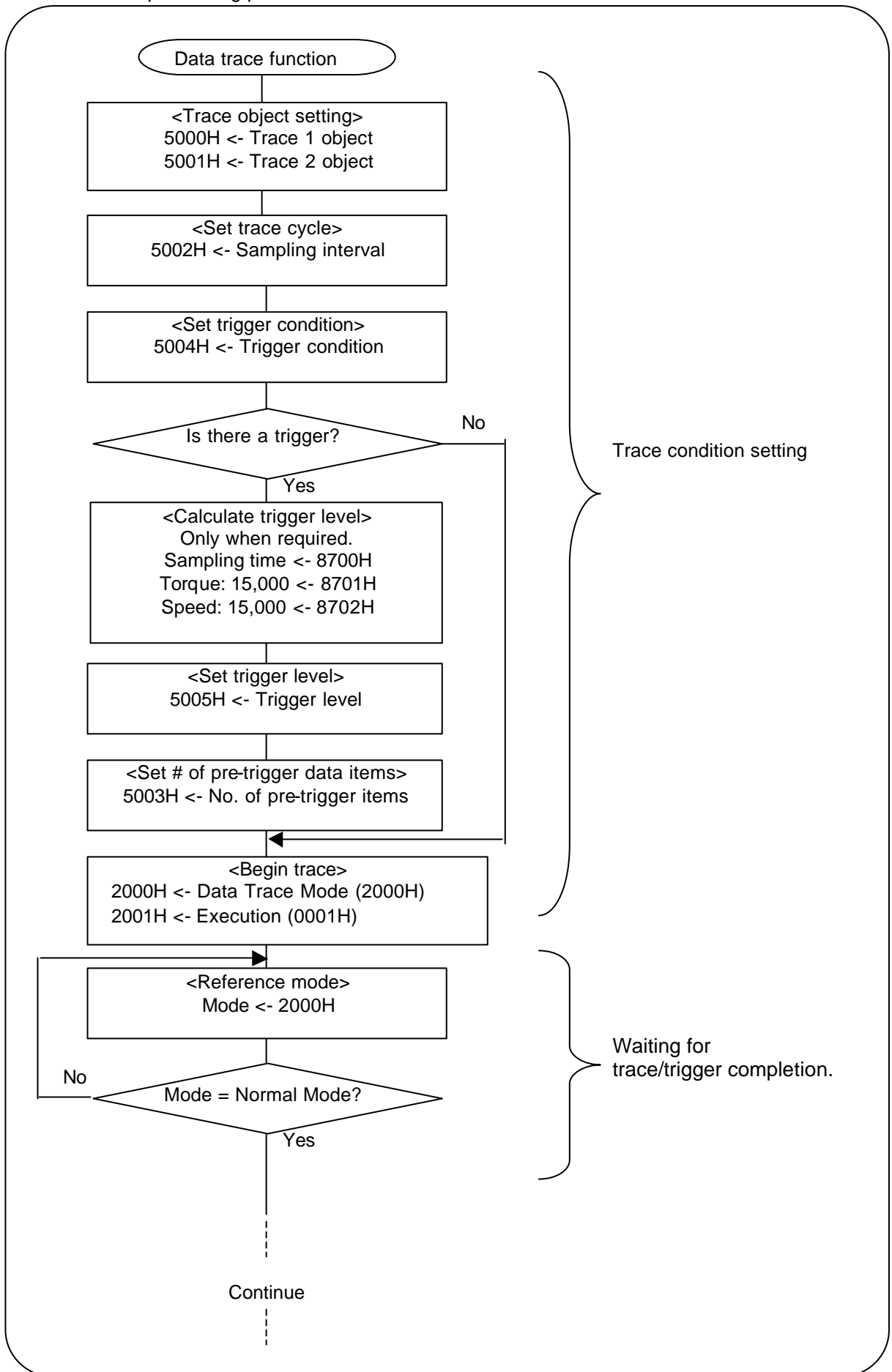

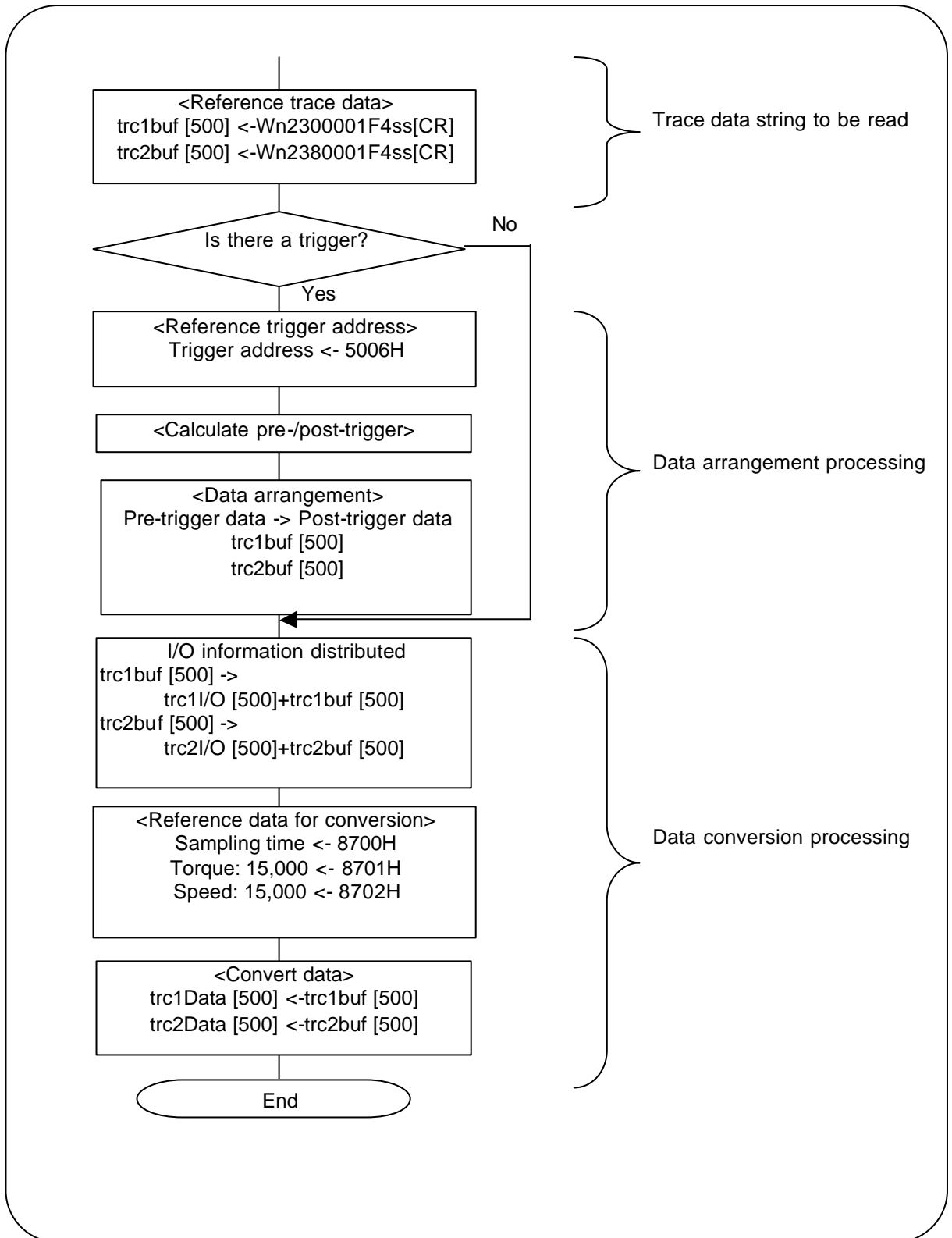

Note: In the above example, the data shown below is ultimately obtained, arranged according to the trace order.

trc1Data [500]	Trace 1 trace data
trc2Data [500]	Trace 2 trace data
trc1I/O [500]	Trace 1 I/O data
trc2I/O [500]	Trace 2 I/O data

During the process, trc1buff [500] and trc2buff [500] are used as temporary buffers.

5. – COMMAND PULSE COUNTER CLEAR FUNCTION

The contents of the command pulse counter (32 bits) can be cleared setting the operating mode to Command Pulse Counter Clear Mode.

(1) Related Addresses

Address	Contents
2000H	Operating mode setting/reference
2001H	Operation setting (setting only)
800CH	Command pulse counter (rightmost 16 bits)
800DH	Command pulse counter (leftmost 16 bits)

(2) Settings

1. Mode Setting 2000H

Setting	Contents
2003H	Command Pulse Counter Clear Mode
0000H	Normal Mode

When the clear process is completed the mode returns to “Normal Mode”.

Also is possible to exit the “Command Pulse Counter Clear Mode” without clearing the command counter by setting the “Normal Mode” instead the “Execution” instruction.

2. Operation Setting 2001H

Setting	Contents
0001H	Execution

When “1” is set in this address the command pulse counter is cleared. When the operation is finished this bit returns to “0” but take into account that this parameter is only for reading.

Note:

The command pulse counter is not a latch data (not synchronous), it means that input pulses couldn't be read correctly unless the command pulses are stopped.

6. – FEEDBACK PULSE COUNTER CLEAR FUNCTION

The contents of the feedback pulse counter (32 bits) can be cleared setting the operating mode to Feedback Pulse Counter Clear Mode.

(1) Related Addresses

Address	Contents
2000H	Operating mode setting/reference
2001H	Operation setting (setting only)
800EH	Feedback pulse counter (rightmost 16 bits)
800FH	Feedback pulse counter (leftmost 16 bits)

(2) Settings

1. Mode Setting 2000H

Setting	Contents
2004H	Feedback Pulse Counter Clear Mode
0000H	Normal Mode

When the clear process is completed the mode returns to “Normal Mode”.

Also is possible to exit the “Feedback Pulse Counter Clear Mode” without clearing the Feedback counter by setting the “Normal Mode” instead the “Execution” instruction.

2. Operation Setting 2001H

Setting	Contents
0001H	Execution

When "1" is set in this address the feedback pulse counter is cleared. When the operation is finished this bit returns to "0" but take into account that this parameter is only for reading.

Note:

The feedback pulse counter is not a latch data (not synchronous), it means that input pulses couldn't be read correctly unless the command pulses are stopped